

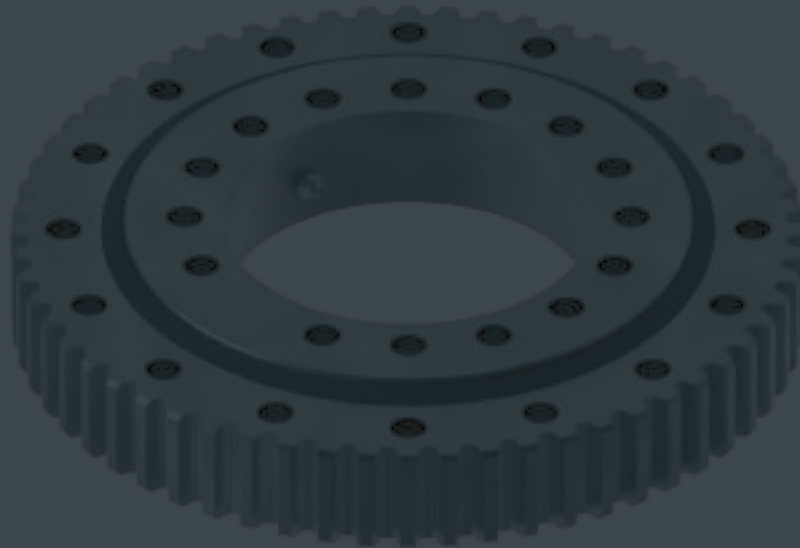

# SLEWING

DRIVES & BEARINGS



Precision. Motion Control. Technology.



Cone Drive is a world leader in precision motion control technology.

We work with our customers every step of the way – from design specs to the final solution – to create highly precise, highly specific products that keep our customers' technology at the forefront of their industry. Cone Drive offers engineering support, unique solutions, and innovative technology across a breadth of markets and products to drive your company forward.



# TABLE OF CONTENTS

## SLEW DRIVES & SLEW BEARINGS

<b>INTRO</b>	<b>4</b>
ONLINE CONFIGURATOR	4 - 6
DOUBLE REDUCTION SLEW DRIVE	7
PRODUCT RANGE	8 - 9
TERMINOLOGY	10
<b>DRIVES</b>	<b>11</b>
PRODUCT CODE	12 - 17
COMPARISON MATRICES	18 - 19
W	20 - 27
WE	28 - 34
WEA	35 - 48
WEB	49 - 61
SE	62 - 70
SEA	71 - 76
SEB	77 - 83
HSE	84 - 93
HES	94 - 95
1000/4000	96 - 97
INSTALLATION, OPERATION, AND MAINTENANCE INSTRUCTIONS	98 -105
<b>BEARINGS</b>	<b>106</b>
STOCKING PROFILE	107
CD-MTO	108 - 110
CD-MTE	111 - 112
CD RK6	113 - 115
Q, 01, 11, HS, 02, 13 SUMMARY TABLES	
Q	118 - 119
01	120 - 121
11	122 - 123
HS	124 - 125
020	126 - 127
13	128 - 129
INSTALLATION, OPERATION, AND MAINTENANCE INSTRUCTIONS	130 - 137

# Configure Your Cone Drive Product Online

[www.ConeTools.com](http://www.ConeTools.com)

Cone Drive's Product Configurator provides multiple tools and resources to offer guidance throughout your product selection process.

The screenshot displays the Cone Drive Product Configurator interface, organized into several sections:

- NEMA DRIVEN: RIGHT ANGLE WORM GEARBOX SOLUTIONS**
  - GETTING STARTED: CONSIDER NEMA DRIVEN PRODUCT SPECIFICATIONS
  - NEMA COMPETITOR INTERCHANGE: INTERCHANGING COMPETITOR LINE WITH SERIES W OR SERIES I
  - Series HP: CONFIGURE
  - Series RG: CONFIGURE
  - Series HP-A: CONFIGURE
  - Series B: CONFIGURE
  - Series F Stainless Steel: CONFIGURE
- SERVO DRIVEN: RIGHT ANGLE WORM GEARBOX SOLUTIONS**
  - GETTING STARTED: CONSIDER SERVO DRIVEN PRODUCT SPECIFICATIONS
  - SERVO SELECTOR: BUILD SOLUTION BASED ON SERVO MOTOR SELECTION
  - Series W: CONFIGURE
  - Series RG: CONFIGURE
  - Series HP: CONFIGURE
  - Series S: CONFIGURE
  - Series FS Stainless Steel: CONFIGURE
- INLINE SOLUTIONS**
  - HARMONIC COMPETITOR INTERCHANGE
  - Harmonic Solutions: CONFIGURE
  - Planetary Drives: CONFIGURE
- CYCLOIDAL SOLUTIONS**
  - SPINEA** BY TAYLOR
  - TwinSpin®: CONFIGURE
  - DriveSpin®: CONFIGURE
- SLEWING SOLUTIONS**
  - SLEW COMPETITOR INTERCHANGE
  - Slew Drives: CONFIGURE
  - Slew Bearings: CONFIGURE

# Available Tools

View comparison chart of high level specs for NEMA motor driven products



**GETTING STARTED: COMPARE NEMA DRIVEN PRODUCT SPECIFICATIONS**

Product	Series HP	Series HP-A	Series M	Series MO	Series F
Size	1.5L (300)	2.0L (400)	3.0L (600)	4.0L (800)	5.0L (1000)
Construction	Cast Iron	Cast Iron	Cast Iron	Cast Iron	Cast Iron
Frame	56 (NEMA)	56 (NEMA)	56 (NEMA)	56 (NEMA)	56 (NEMA)
Output Torque (Constant Speed)	~1.5 (1000) lb-ft	~2.0 (1400) lb-ft	~3.0 (2100) lb-ft	~4.0 (2800) lb-ft	~5.0 (3500) lb-ft
Speed (RPM)	1725	1725	1725	1725	1725
IP Rating	IP54	IP54	IP54	IP54	IP54
Warranty	3 Year	3 Year	3 Year	3 Year	3 Year

View comparison chart of high level specs for servo motor driven products



**GETTING STARTED: COMPARE SERVO DRIVEN PRODUCT SPECIFICATIONS**

Product	Series SE	Series SEB	Series S	Series SE1	Series SE2
Size	4000 mm	2.0 (200)	4.0 (400)	6.0 (600)	8.0 (800)
Construction	Aluminum	Cast Iron	Aluminum	Cast Iron	Cast Iron
Mounting Bracket Design	2.0 (200)	2.0 (200)	2.0 (200)	2.0 (200)	2.0 (200)
Size	2.0 (200)	2.0 (200)	2.0 (200)	2.0 (200)	2.0 (200)
Rated Torque (Constant Speed)	~1.5 (1000) lb-ft	~2.0 (1400) lb-ft	~3.0 (2100) lb-ft	~4.0 (2800) lb-ft	~5.0 (3500) lb-ft
Output Torque (Maximum)	~3.0 (2100) lb-ft	~4.0 (2800) lb-ft	~6.0 (4200) lb-ft	~8.0 (5600) lb-ft	~10.0 (7000) lb-ft
IP Rating	IP54	IP54	IP54	IP54	IP54
Warranty	3 Year	3 Year	3 Year	3 Year	3 Year

Select a Cone Drive replacement for competitor unit



- NEMA COMPETITOR INTERCHANGE: INTERCHANGE COMPETITOR UNIT WITH SERIES B OR SERIES F
- SLEW COMPETITOR INTERCHANGE
- HARMONIC COMPETITOR INTERCHANGE

Filter available Cone Drive units by servo motor selection



**SERVO SELECTOR: BUILD A GEARBOX BASED ON SERVO MOTOR SELECTION**

# Build a Gearbox to Fit Your Specific Needs

CONFIGURE

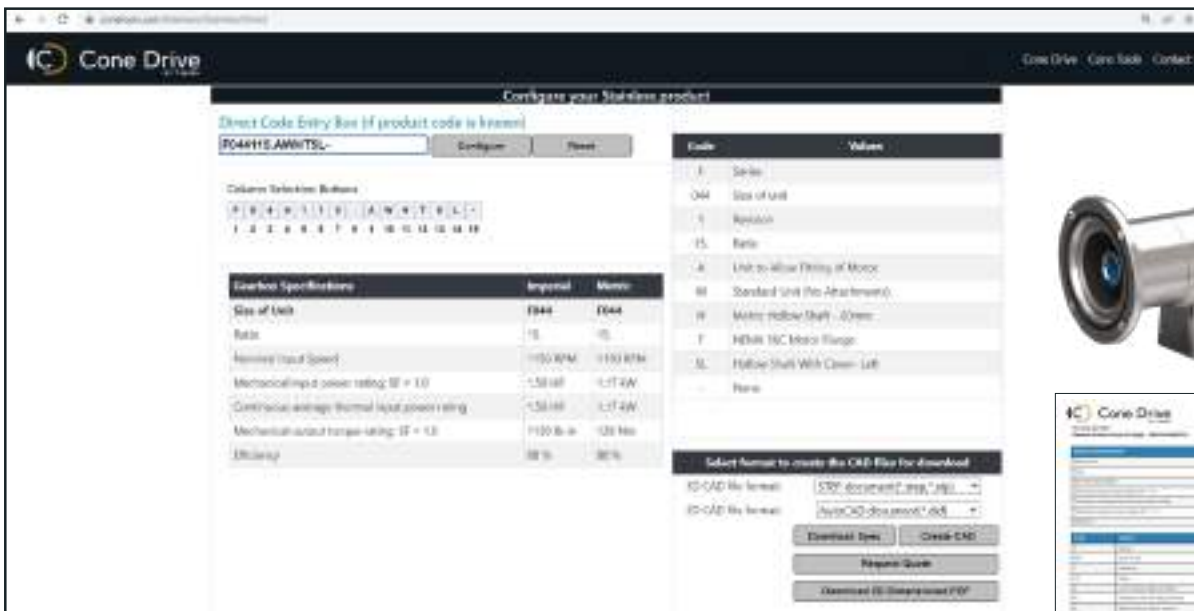
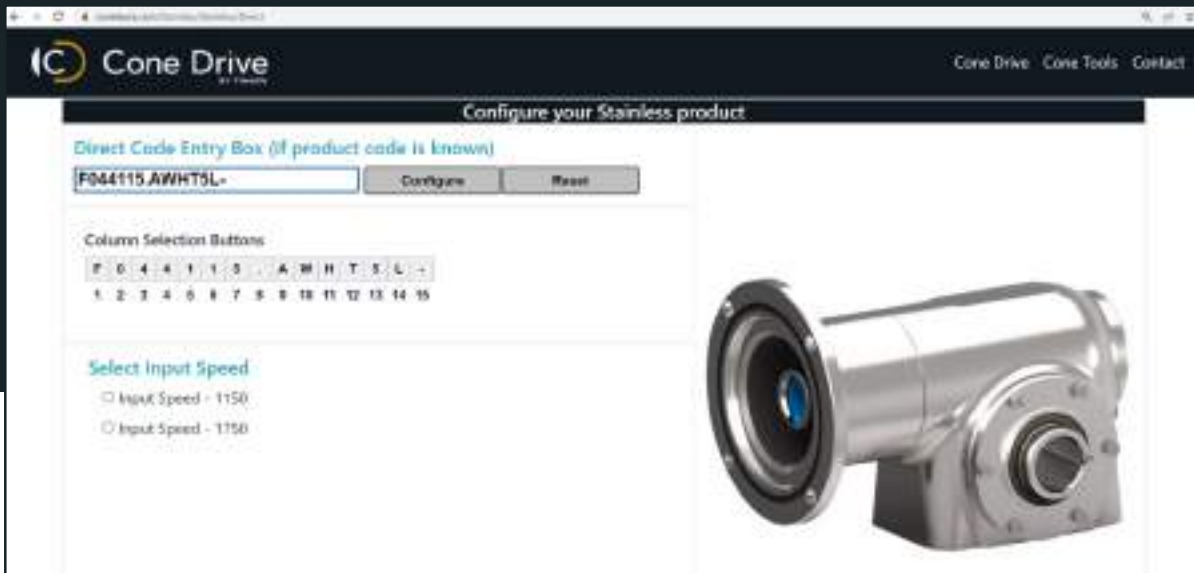

Download specifications, models, and submit your customized unit to Cone Drive for a quote.



# ELECTRIC DRIVEN DOUBLE REDUCTION

## READY TO GET RID OF YOUR MESSY, HYDRAULIC SYSTEM?

Cone Drive has you covered with our double reduction slew drives. When using an electric motor (Servo or NEMA) to power a slewing drive, it is recommended to install a planetary gear as the primary reducer. This combination offers superior control, ease of integration into your systems, energy efficiency, and reduced maintenance. Cone Drive stocks a family of adapters and shafts for the most common primary gearboxes, ensuring a quick turnaround and a one-stop solution for your double reduction slew drive needs.

## CLEAN, EFFICIENT POWER

- Clean setup
- Superior control
- Ease of integration
- Energy efficient
- Reduced maintenance
- Adapters in stock

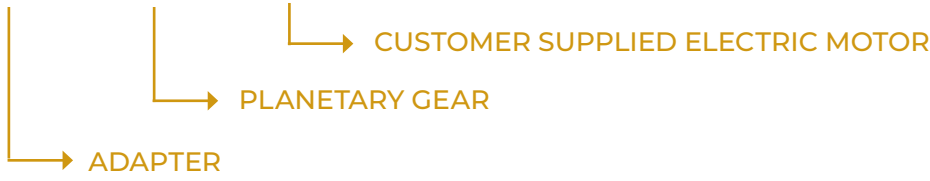
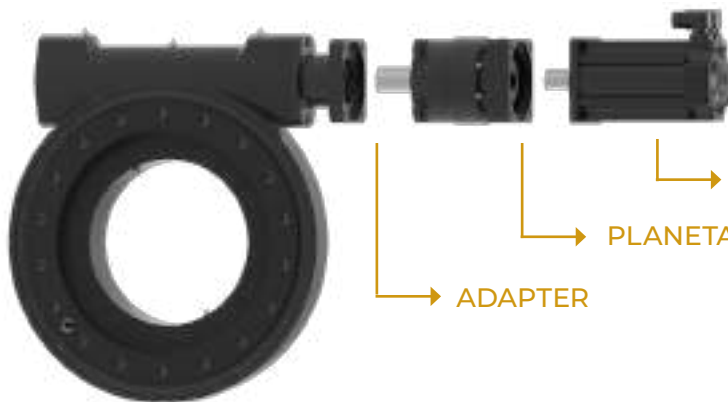

# SERVO DRIVEN POWER PRECISION MOTION CONTROL

Cone Drive's precision gearing solutions exceed the most demanding needs in motion control applications. Available in both right angle and in-line configurations, we have a variety of products to fit your precision and power needs.

## RIGHT ANGLE, DOUBLE ENVELOPING WORM GEAR



### SERIES FS

- Low or standard backlash
- IP69k
- 316 stainless steel adapter and housing
- Viton™ output seals
- 5 year warranty



### SERIES W

- Zero, low, or standard backlash
- Aluminum housing
- Angular contact ball bearings (worm shaft)
- Zero backlash bellows style coupling
- 5 year warranty



### SERIES RG

- Low or standard backlash
- Cast iron housing
- White epoxy or stainless steel paint available
- 5 year warranty



### SERIES S

- Conex proprietary worm gearing
- Aluminum housing
- USDA white epoxy paint available
- Optional wash down design
- 2 year warranty



### SERIES HP

- Low or standard backlash
- Vented, cast iron housing
- Bellows or jaw style coupling
- 5 year warranty

## IN-LINE PRECISION



### CONE DRIVE HARMONIC SOLUTIONS®

- Low to zero backlash
- High transmission accuracy
- Customizations available upon request
- 1 year warranty



### SPINEA CYCLOIDAL TWINSPIN®

- Low backlash
- High reduction ratio
- High kinematic accuracy
- High moment capacity and stiffness
- Compact and lightweight



### SPINEA CYCLOIDAL DRIVESPIN®

- Zero backlash
- Dynamic, high performance actuator
- Compact design
- High torsional and tilting stiffness



### PLANETARY SOLUTIONS

- Quiet operation
- Low backlash, high efficiency
- Stainless steel option
- Competitive interchanges available
- 5 year warranty



# NEMA DRIVEN POWER INDUSTRIAL MOTION CONTROL

Cone Drive's industrial gearboxes are built to control motion and deliver torque. Our right angle worm solutions are available in a wide variety of sizes and ratios and feature customizations sure to adapt to a variety of applications.

## RIGHT ANGLE, DOUBLE ENVELOPING WORM GEAR



### SERIES HP

- Single, double, or triple reduction
- Vented, cast iron construction
- Fan or water cooling available
- Wide range of sizes
- 5 year warranty



### SERIES HP-A

- Universal housing
- Cast iron construction
- Fan cooling available
- Viton™ seals available
- Optional drywell feature
- 5 year warranty



### SERIES RG

- Single or in-line double reduction
- Cast iron housing
- Optional low backlash
- White epoxy or stainless steel paint available
- 5 year warranty



### SERIES F

- IP69k rated
- 316 stainless steel adapter and housing
- Viton™ output seals
- Single or in-line double reduction
- Optional low backlash
- 5 year warranty



### SERIES B

- Conex proprietary worm gearing
- Aluminum housing
- Single or double reduction
- Optional washdown design
- 2 year warranty

## PINCH ROLLING



### DUODRIVE

- Designed for pinch rolling applications
- One input shaft powering two output gears
- Unequal ratio configurations available
- Cast iron housing
- Water or fan cooled
- 5 year warranty

## SLEWING



### SLEW DRIVES & SLEW BEARINGS

- Select sizes available from stock
- Low profile
- Sealed drive options available
- Capable of combined tilting, radial, and axial loads
- Strong shock resistance
- Long life performance
- 2 year warranty

## SOLAR & TRACKING



### SLEW DRIVES & SLEW BEARINGS

- Select sizes available from stock
- Low profile
- Sealed drive options available
- Capable of combined tilting, radial, and axial loads
- Strong shock resistance
- Long life performance
- 2 year warranty

## TILTING MOMENT

Tilting Moment is the force multiplied by the distance from that force to the center of the slewing ring.

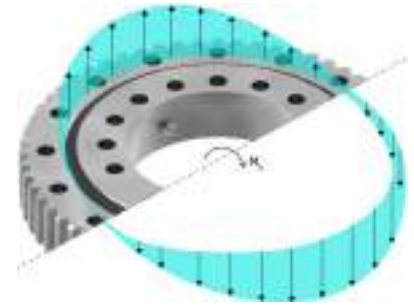

## RADIAL LOAD

Radial Load is the force perpendicular to the slewing ring axis.



## AXIAL LOAD

Axial Load is the force parallel to the slewing ring axis.

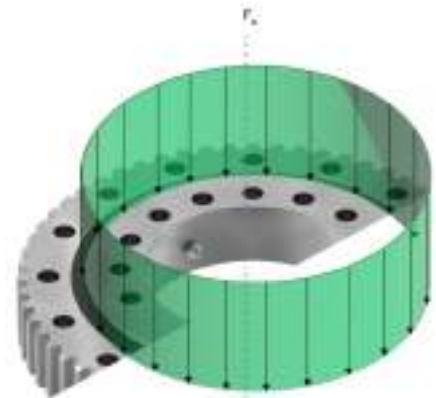

## HOLDING TORQUE

The maximum static (held) back driving torque, that the unit can react without damage to the drive.



## SELF-LOCKING

Self-Locking is the ability of the slewing drive to resist rotation when holding torque is applied to the slewing bearing.



# SLEWING DRIVES



1	2	3	4	5	6	7	8	9	10	11	12	13	14	15	16
SE	14	A	-	85	B	T	-	B	H	-	2	R	-	160	A

## 1 SERIES

W	Open Housing, Cylindrical Worm
WE	Enclosed Housing, Cylindrical Worm
WEA	Enclosed Housing, Advanced Sealing, Cylindrical Worm
WEB	Enclosed Housing, Dual Oil Seal, Cylindrical Worm
S	Open Housing, Hourglass Worm
SE	Enclosed Housing, Hourglass Worm
SEA	Enclosed Housing, Advanced Sealing, Hourglass Worm
HSE	Enclosed Housing, Advanced Sealing, Hourglass Worm, Bronze Gear
R	Enclosed Housing, Cylindrical Worm, Bronze Gear, Compact Drive
P	Open Housing, Precision Cylindrical Worm
PE	Enclosed Housing, Precision Cylindrical Worm
PEA	Enclosed Housing, Precision Advanced Sealing, Cylindrical Worm
PEB	Enclosed Housing, Precision Dual Oil Seal, Cylindrical Worm

-2 Designation Indicates Dual Worm Design

## 2 DIAMETER OF RACEWAY (IN INCHES)

3	12	19
5	14	21
7	15	25
9	17	28

## 3 REVISION

A
---

## 5 REDUCTION RATIO : 1

RACEWAY	W	WE	WEA	WEB	S	SE	SEA	SEB	HSE
3						62			
5						62			
7	47		47	47		73	73	73	47
9	62	62	62	62	61	61	61	61	62
12	79	79	79	79	78	78	78	78	79
14	86	86	86	86	85	85	85	85	86
15			92	92					
17	104	104	104	104		102	102	102	104
19	94		94	94					94
21	90	90	90	90		125	125	125	90
25	104	104	104	104		150	150	150	94
28			110						

## 6 MOUNTING HOLE UNITS

-	Metric
B	Imperial

\*Available options depend on size; reference pages 14 - 17 for availability

We reserve the right to improve or change product design and specifications without notice.

## 7 HOLE TYPE\*

	OUTER RING	INNER RING
-	Blind Threaded Holes	Blind Threaded Holes
C	Threaded Thru Holes	Threaded Thru Holes
T	Blind Threaded Holes	Thru Holes

## 9 WORM SHAFT\*

-	Omitted with hydraulic motor
B	SAE 6B spline
12	12 mm keyed shaft
14	14 mm keyed shaft
16	16 mm keyed shaft
20	20 mm keyed shaft
25	25 mm keyed shaft
50	50 mm keyed shaft
25.4	1 inch keyed shaft

## 10 SHAFT OPPOSITE TO MOTOR

-	Solid
H	Hex
E	Encoder

## 12 NUMBER OF WORMS

-	Single Worm Drive
2	Dual Worm Drive

## 13 MOTOR INPUT POSITION

R	Right
L	Left

## 15 MOTOR DISPLACEMENT (CC/REV)

-	Electric or No Motor
50	200
80	250
100	315
130	400
160	

## 16 HYDRAULIC OIL PORT DIRECTION

A	Away
I	Inside
U	Up
D	Down

## 6 & 7 HOLE TYPE

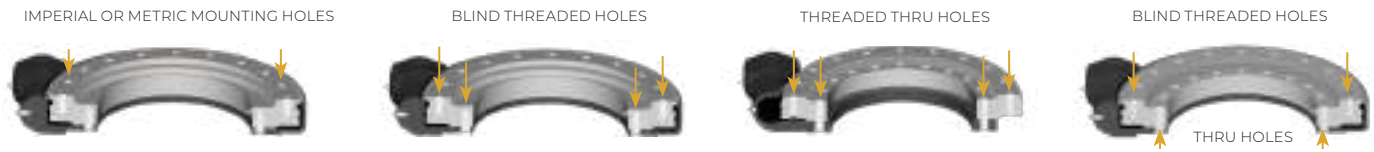

## 10 WORM SHAFT



## 12 NUMBER OF WORMS



## 13 MOTOR INPUT POSITION



## 16 HYDRAULIC OIL PORT DIRECTION

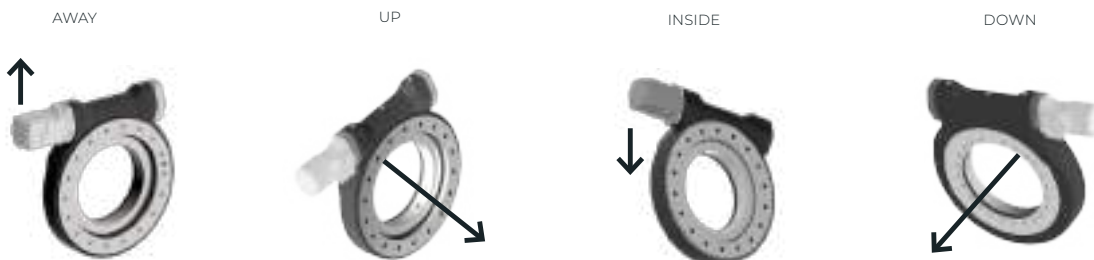



# IC Slew Drive Size Dependent Options

SERIES	SIZE	RATIO	TYPE OF MOUNTING	INPUT							
				SAE 6B	12	14	16	20	25	50	25.4
W	7	47	-	Y	Y	Y	Y	Y	Y		Y
			T	Y	Y	Y	Y	Y	Y		Y
W	9	62	-	Y	Y	Y	Y	Y	Y		Y
			C	Y	Y	Y	Y	Y	Y		Y
			T	Y	Y	Y	Y	Y	Y		Y
W	12	79	-	Y	Y	Y	Y	Y	Y		Y
			C	Y	Y	Y	Y	Y	Y		Y
			T	Y	Y	Y	Y	Y	Y		Y
W	14	86	-	Y	Y	Y	Y	Y	Y		Y
			C	Y	Y	Y	Y	Y	Y		Y
			T	Y	Y	Y	Y	Y	Y		Y
W	17	104	-	Y	Y	Y	Y	Y	Y		Y
			C	Y	Y	Y	Y	Y	Y		Y
			T	Y	Y	Y	Y	Y	Y		Y
W	19	94	-	Y	Y	Y	Y	Y	Y		Y
			C	Y	Y	Y	Y	Y	Y		Y
			T	Y	Y	Y	Y	Y	Y		Y
W	21	90	-	Y			Y	Y	Y		Y
			C	Y			Y	Y	Y		Y
			T	Y			Y	Y	Y		Y
W	25	104	-	Y				Y	Y		Y
			C	Y				Y	Y		Y
			T	Y				Y	Y		Y
WE	9	62	-	Y	Y	Y	Y	Y	Y		Y
			T	Y	Y	Y	Y	Y	Y		Y
WE	12	79	-	Y	Y	Y	Y	Y	Y		Y
			T	Y	Y	Y	Y	Y	Y		Y
WE	14	86	-	Y	Y	Y	Y	Y	Y		Y
			T	Y	Y	Y	Y	Y	Y		Y
WE	17	104	-	Y	Y	Y	Y	Y	Y		Y
			T	Y	Y	Y	Y	Y	Y		Y
WE	21	90	-	Y			Y	Y	Y		Y
			T	Y			Y	Y	Y		Y
WE	25	104	-	Y				Y	Y		Y
			T	Y				Y	Y		Y

SERIES	SIZE	RATIO	TYPE OF MOUNTING	INPUT							
				SAE 6B	12	14	16	20	25	50	25.4
WEA	7	47	-	Y	Y	Y	Y	Y	Y		Y
			T	Y	Y	Y	Y	Y	Y		Y
WEA	9	62	-	Y	Y	Y	Y	Y	Y		Y
			T	Y	Y	Y	Y	Y	Y		Y
WEA	12	79	-	Y	Y	Y	Y	Y	Y		Y
			T	Y	Y	Y	Y	Y	Y		Y
WEA	14	86	-	Y	Y	Y	Y	Y	Y		Y
			T	Y	Y	Y	Y	Y	Y		Y
WEA	15	92	-	Y	Y	Y	Y	Y	Y		Y
			T	Y	Y	Y	Y	Y	Y		Y
WEA	17	104	-	Y	Y	Y	Y	Y	Y		Y
			T	Y	Y	Y	Y	Y	Y		Y
WEA	19	94	-	Y				Y	Y		Y
			T	Y				Y	Y		Y
WEA	21	90	-	Y			Y	Y	Y		Y
			T	Y			Y	Y	Y		Y
WEA	25	104	-	Y				Y	Y		Y
			T	Y				Y	Y		Y
WEA	28	110	-	Y					Y	Y	
			T	Y					Y	Y	
WEB	7	47	-	Y	Y	Y	Y	Y	Y		Y
			T	Y	Y	Y	Y	Y	Y		Y
WEB	9	62	-	Y	Y	Y	Y	Y	Y		Y
			T	Y	Y	Y	Y	Y	Y		Y
WEB	12	79	-	Y	Y	Y	Y	Y	Y		Y
			T	Y	Y	Y	Y	Y	Y		Y
WEB	14	86	-	Y	Y	Y	Y	Y	Y		Y
			T	Y	Y	Y	Y	Y	Y		Y
WEB	15	92	-	Y	Y	Y	Y	Y	Y		Y
			T	Y	Y	Y	Y	Y	Y		Y
WEB	17	104	-	Y	Y	Y	Y	Y	Y		Y
			T	Y	Y	Y	Y	Y	Y		Y
WEB	19	94	-	Y				Y	Y		Y
			T	Y				Y	Y		Y
WEB	21	90	-	Y			Y	Y	Y		Y
			T	Y			Y	Y	Y		Y
WEB	25	104	-	Y				Y	Y		Y
			T	Y				Y	Y		Y

# IC Slew Drive Size Dependent Options

SERIES	SIZE	RATIO	TYPE OF MOUNTING	INPUT							
				SAE 6B	12	14	16	20	25	50	25.4
S	9	61	-	Y	Y	Y	Y	Y	Y		Y
			C	Y	Y	Y	Y	Y	Y		Y
			T	Y	Y	Y	Y	Y	Y		Y
S	12	78	-	Y	Y	Y	Y	Y	Y		Y
			C	Y	Y	Y	Y	Y	Y		Y
			T	Y	Y	Y	Y	Y	Y		Y
S	14	85	-	Y	Y	Y	Y	Y	Y		Y
			C	Y	Y	Y	Y	Y	Y		Y
			T	Y	Y	Y	Y	Y	Y		Y
SE	3	62	-	Y	Y	Y	Y	Y	Y		Y
			T	Y	Y	Y	Y	Y	Y		Y
SE	5	62	-	Y	Y	Y	Y	Y	Y		Y
			T	Y	Y	Y	Y	Y	Y		Y
SE	7	73	-	Y	Y	Y	Y	Y	Y		Y
			T	Y	Y	Y	Y	Y	Y		Y
SE	9	61	-	Y	Y	Y	Y	Y	Y		Y
			T	Y	Y	Y	Y	Y	Y		Y
SE	12	78	-	Y	Y	Y	Y	Y	Y		Y
			T	Y	Y	Y	Y	Y	Y		Y
SE	14	85	-	Y	Y	Y	Y	Y	Y		Y
			T	Y	Y	Y	Y	Y	Y		Y
SE	17	102	-	Y			Y	Y	Y		Y
			T	Y			Y	Y	Y		Y
SE	21	125	-	Y			Y	Y	Y		Y
			T	Y			Y	Y	Y		Y
SE	25	150	-	Y			Y	Y	Y		Y
			T	Y			Y	Y	Y		Y
SEA	7	73	-		Y	Y	Y				
			T		Y	Y	Y				
SEA	9	61	-	Y	Y	Y	Y	Y	Y		Y
			T	Y	Y	Y	Y	Y	Y		Y
SEA	12	78	-	Y	Y	Y	Y	Y	Y		Y
			T	Y	Y	Y	Y	Y	Y		Y
SEA	14	85	-	Y	Y	Y	Y	Y	Y		Y
			T	Y	Y	Y	Y	Y	Y		Y
SEA	17	102	-	Y			Y	Y	Y		Y
			T	Y			Y	Y	Y		Y

SERIES	SIZE	RATIO	TYPE OF MOUNTING	INPUT							
				SAE 6B	12	14	16	20	25	50	25.4
SEA	21	125	-	Y			Y	Y	Y		Y
			T	Y			Y	Y	Y		Y
SEA	25	150	-	Y			Y	Y	Y		Y
			T	Y			Y	Y	Y		Y
SEB	7	73	-		Y	Y	Y				
			T		Y	Y	Y				
SEB	9	61	-	Y	Y	Y	Y	Y	Y		Y
			T	Y	Y	Y	Y	Y	Y		Y
SEB	12	78	-	Y	Y	Y	Y	Y	Y		Y
			T	Y	Y	Y	Y	Y	Y		Y
SEB	14	85	-	Y	Y	Y	Y	Y	Y		Y
			T	Y	Y	Y	Y	Y	Y		Y
SEB	17	102	-	Y			Y	Y	Y		Y
			T	Y			Y	Y	Y		Y
SEB	21	125	-	Y			Y	Y	Y		Y
			T	Y			Y	Y	Y		Y
SEB	25	150	-	Y			Y	Y	Y		Y
			T	Y			Y	Y	Y		Y
HSE	7	47	-	Y					Y		
			T	Y					Y		
HSE	9	62	-	Y					Y		
			T	Y					Y		
HSE	12	79	-	Y					Y		
			T	Y					Y		
HSE	14	86	-	Y					Y		
			T	Y					Y		
HSE	17	104	-	Y					Y		
			T	Y					Y		
HSE	19	94	-	Y					Y		
			T	Y					Y		
HSE	21	90	-	Y					Y		
			T	Y					Y		
HSE	25	94	-	Y					Y		
			T	Y					Y		

**CYLINDRICAL WORM SLEWING DRIVES**



PRODUCT	W	WE	WEA	WEB
Sizes	7 - 25"	9 - 28"	7 - 28"	7 - 25"
Housing	Open	Enclosed		
Dual Worm Available	No	No	Yes	Yes
Gear	Steel	Steel	Steel	Steel
Inner Seal	Dust Seal	Dust Seal	Dust Seal	Advanced
Outer Seal	Open	Dust Seal	Advanced	Advanced



## HOURGLASS WORM SLEWING DRIVES



PRODUCT	S	SE/PE	SEA/PEA	SEB/PEB	HSE
Sizes	9 - 25"	3 - 25"	7 - 25"	7 - 25"	7 - 25"
Housing	Open	Enclosed			
Dual Worm Available	Yes	Yes	No	No	Yes
Gear	Steel	Steel	Steel	Steel	Bronze
Inner Seal	Dust Seal	Dust Seal*	Dust Seal	Advanced	Advanced
Outer Seal	Open	Dust Seal**	Advanced	Advanced	Advanced

\* Advanced Sealing on Sizes 3 and 5

\*\* Advanced Sealing on Sizes 3 - 7

All dimensions in mm unless otherwise specified

## FRONT

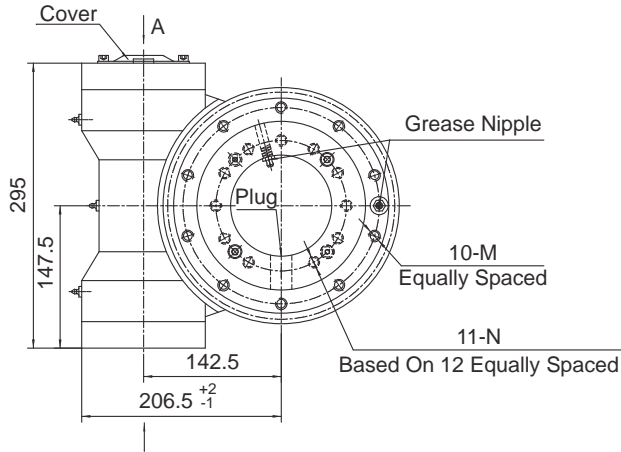

## SIDE

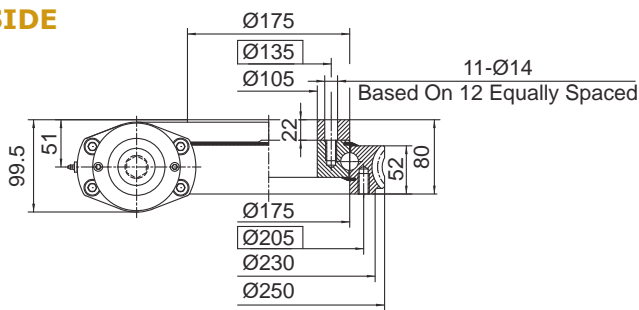

## INPUT

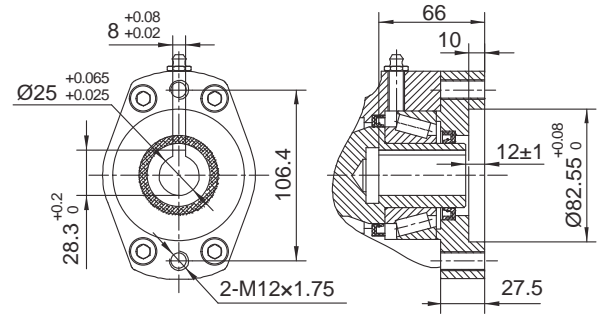

Ø25

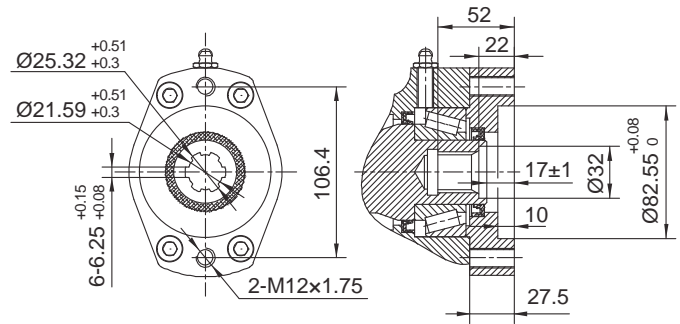

6B SPLINE

## MOMENT LOAD CHART

## MOUNTING HOLES OPTION

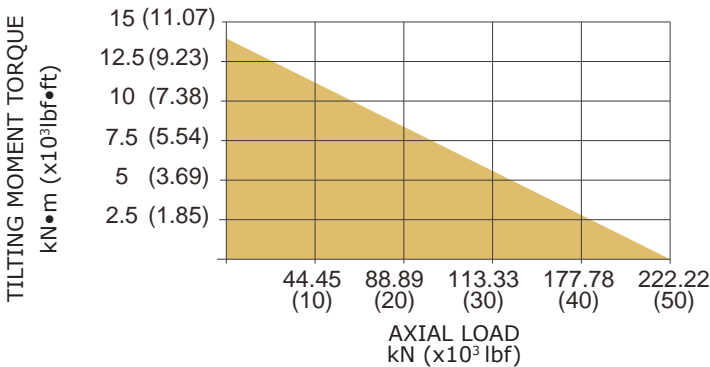

CODE 6&7	M (OUTER RING)	N (INNER RING)
--	M12×1.75 Tap 22	M12×1.75 Tap 22
- T	M12×1.75 Tap 22	Ø14 Thru
B -	1/2"-13UNC-2B Tap 22	1/2"-13UNC-2B Tap 22
B T	1/2"-13UNC-2B Tap 22	Ø14 Thru

## PERFORMANCE PARAMETERS

OUTPUT TORQUE	TILTING MOMENT TORQUE	HOLDING TORQUE	STATIC AXIAL RATING	STATIC RADIAL RATING	DYNAMIC AXIAL RATING	DYNAMIC RADIAL RATING	GEAR RATIO	TRACKING PRECISION	WEIGHT
3.5 kN.m	14.2 kN.m	20 kN.m	220 kN	90 kN	63 kN	48 kN	47 : 1	≤ 0.15°	29 kg
2583 lbf.ft	10.5×10 <sup>3</sup> lbf.ft	14.8×10 <sup>3</sup> lbf.ft	49.5×10 <sup>3</sup> lbf	20.2×10 <sup>3</sup> lbf	14.2×10 <sup>3</sup> lbf	10.8×10 <sup>3</sup> lbf			64 lb

All dimensions in mm unless otherwise specified

## FRONT

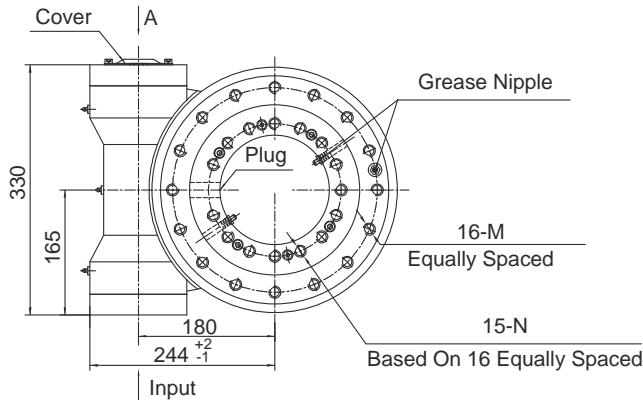

## INPUT

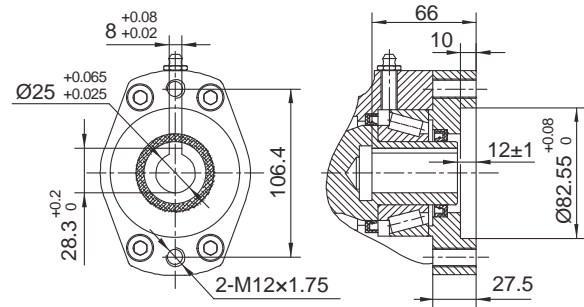

## SIDE

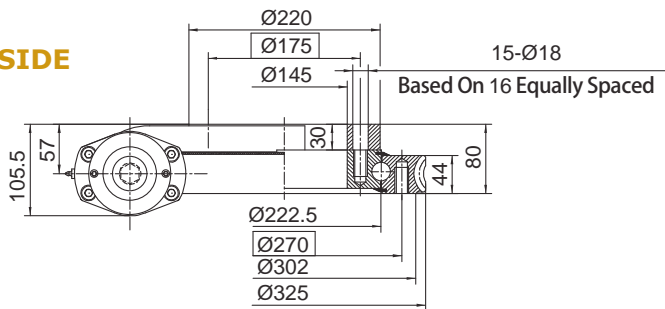

## Ø25

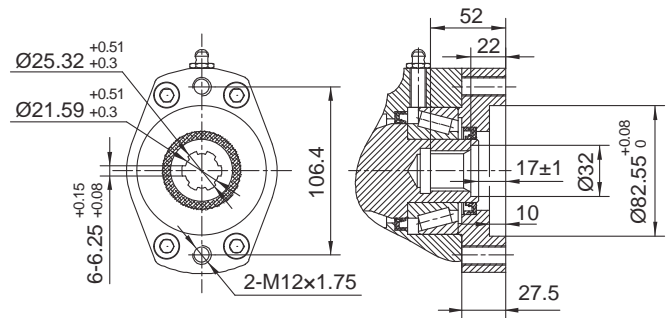

## 6B SPLINE

## MOMENT LOAD CHART

## MOUNTING HOLES OPTION

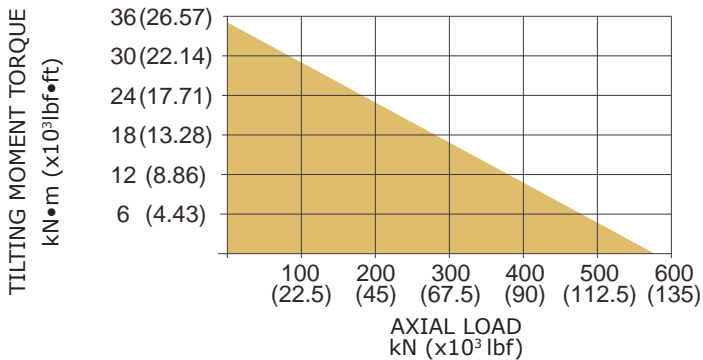

CODE 6&7	M (OUTER RING)	N (INNER RING)
--	M16×2 Tap 30	M16×2 Tap 30
- T	M16×2 Tap 30	Ø18 Thru
B -	5/8"-11UNC-2B Tap 30	5/8"-11UNC-2B Tap 30
B T	5/8"-11UNC-2B Tap 30	Ø18 Thru

## PERFORMANCE PARAMETERS

OUTPUT TORQUE	TILTING MOMENT TORQUE	HOLDING TORQUE	STATIC AXIAL RATING	STATIC RADIAL RATING	DYNAMIC AXIAL RATING	DYNAMIC RADIAL RATING	GEAR RATIO	TRACKING PRECISION	WEIGHT
8 kN.m	35.6 kN.m	34.5 kN.m	578 kN	215 kN	136 kN	115 kN	62 : 1	≤ 0.15°	40 kg
5904 lbf.ft	26.3×10³ lbf.ft	25.5×10³ lbf.ft	129.9×10³ lbf	48.3×10³ lbf	30.6×10³ lbf	25.9×10³ lbf			88 lb

# Series W12 Dimensions and Ratings

All dimensions in mm unless otherwise specified

## FRONT

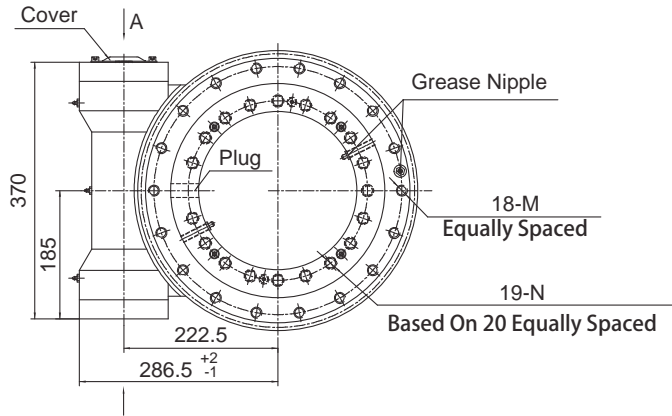

## INPUT

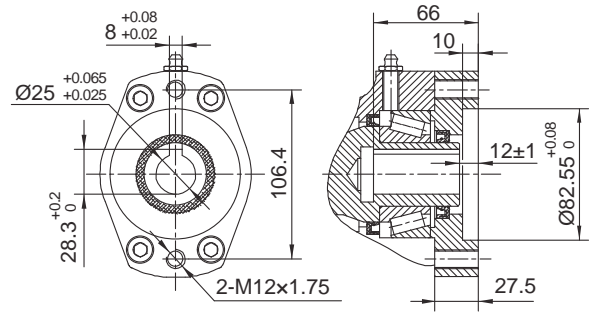

## SIDE

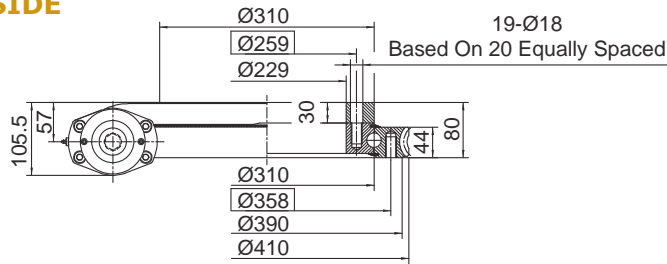

## Ø25

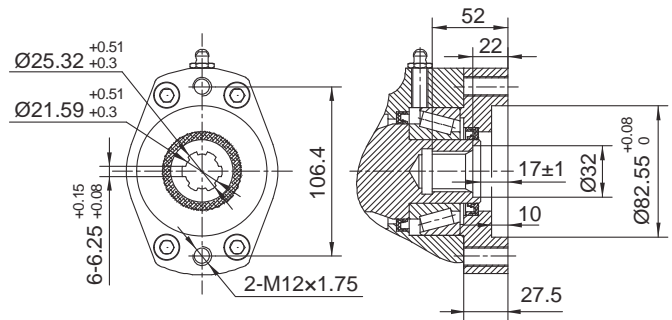

## 6B SPLINE

## MOMENT LOAD CHART

## MOUNTING HOLES OPTION

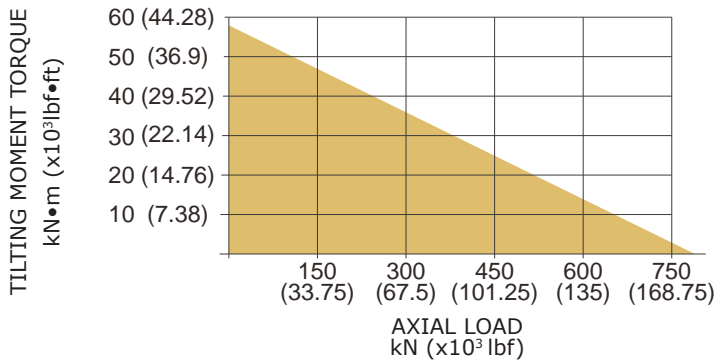

CODE 6&7	M (OUTER RING)	N (INNER RING)
--	M16×2 Tap 30	M16×2 Tap 30
- T	M16×2 Tap 30	Ø18 Thru
B -	5/8"-11UNC-2B Tap 30	5/8"-11UNC-2B Tap 30
B T	5/8"-11UNC-2B Tap 30	Ø18 Thru

## PERFORMANCE PARAMETERS

OUTPUT TORQUE	TILTING MOMENT TORQUE	HOLDING TORQUE	STATIC AXIAL RATING	STATIC RADIAL RATING	DYNAMIC AXIAL RATING	DYNAMIC RADIAL RATING	GEAR RATIO	TRACKING PRECISION	WEIGHT
9.5 kN.m	57 kN.m	43 kN.m	760 kN	280 kN	190 kN	148 kN	79 : 1	≤ 0.15°	52 kg
7011 lbf.ft	42.1×10³ lbf.ft	32×10³ lbf.ft	171.1×10³ lbf	62.9×10³ lbf	42.7×10³ lbf	33.3×10³ lbf			115 lb

All dimensions in mm unless otherwise specified

## FRONT

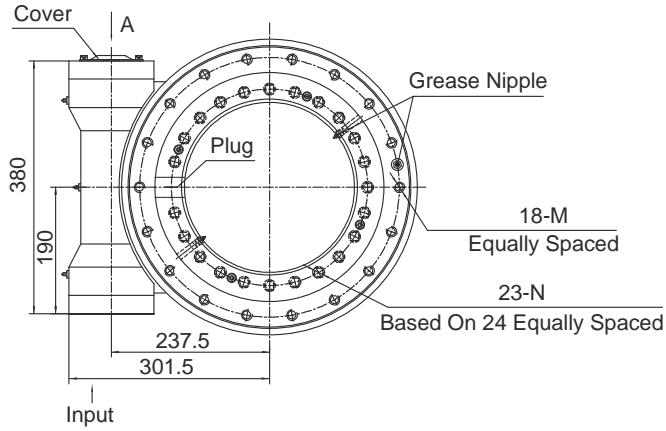

## INPUT

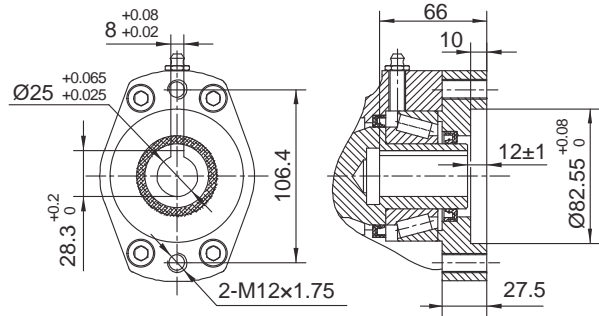

**Ø25**

## SIDE

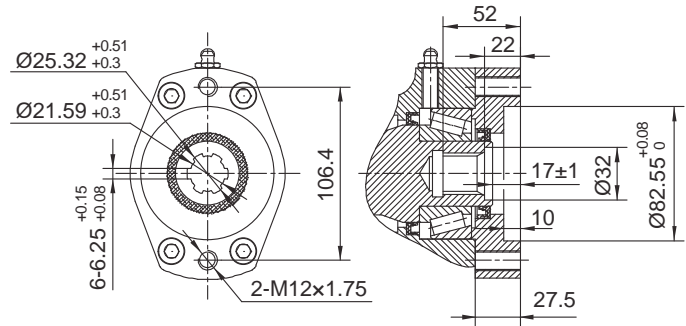
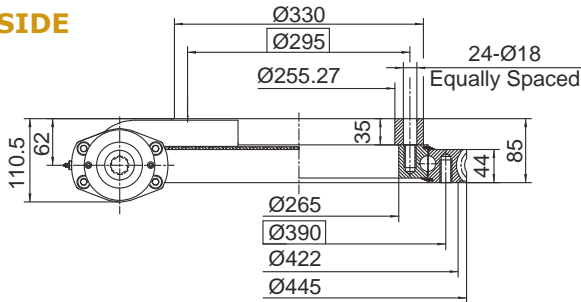

**6B SPLINE**

## MOMENT LOAD CHART

## MOUNTING HOLES OPTION

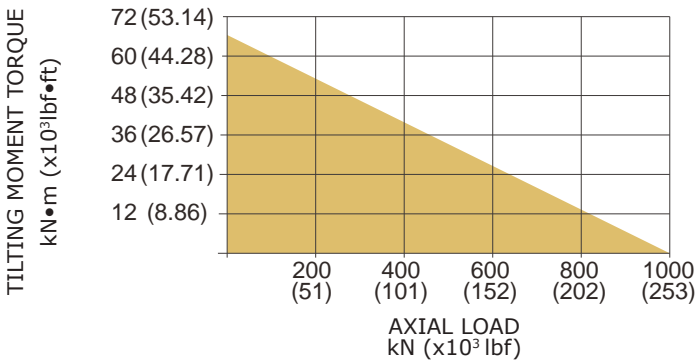

CODE 6&7	M (OUTER RING)	N (INNER RING)
- -	M16×2 Tap 30	M16×2 Tap 30
- T	M16×2 Tap 30	Ø18 Thru
B -	5/8"-11UNC-2B Tap 30	5/8"-11UNC-2B Tap 30
B T	5/8"-11UNC-2B Tap 30	Ø18 Thru

## PERFORMANCE PARAMETERS

OUTPUT TORQUE	TILTING MOMENT TORQUE	HOLDING TORQUE	STATIC AXIAL RATING	STATIC RADIAL RATING	DYNAMIC AXIAL RATING	DYNAMIC RADIAL RATING	GEAR RATIO	TRACKING PRECISION	WEIGHT
10.8 kN.m	71.2 kN.m	48 kN.m	960 kN	360 kN	230 kN	200 kN	86 : 1	≤ 0.13°	62 kg
7970 lbf.ft	52.6×10 <sup>3</sup> lbf.ft	35×10 <sup>3</sup> lbf.ft	215.8×10 <sup>3</sup> lbf	80.9×10 <sup>3</sup> lbf	51.7×10 <sup>3</sup> lbf	44.9×10 <sup>3</sup> lbf			137 lb



# Series W17 Dimensions and Ratings

All dimensions in mm unless otherwise specified

## FRONT

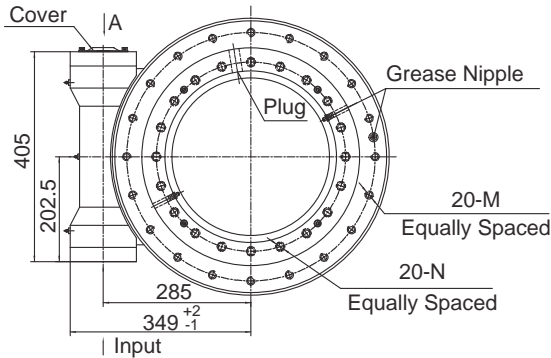

## INPUT

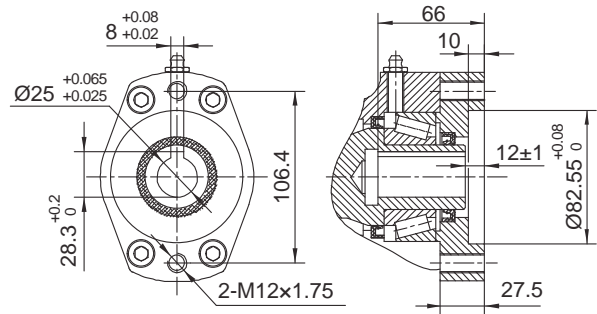

## SIDE

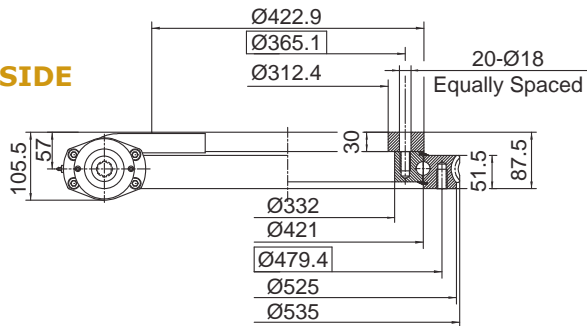

## Ø25

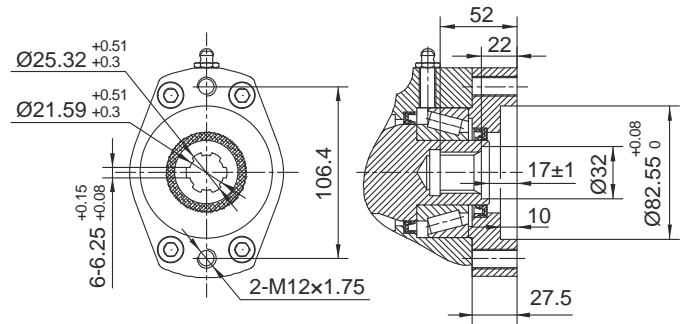

## 6B SPLINE

## MOMENT LOAD CHART

## MOUNTING HOLES OPTION

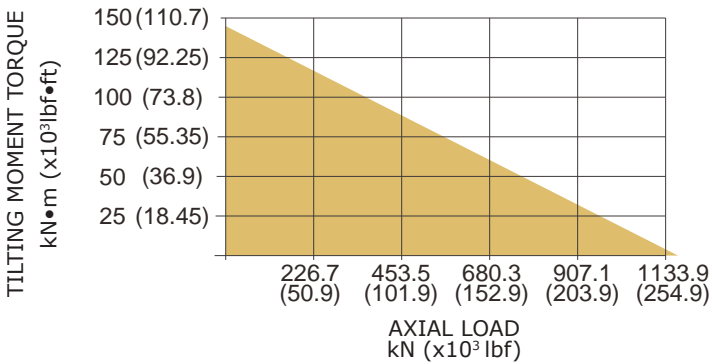

CODE	M (OUTER RING)	N (INNER RING)
6&7	M16×2 Tap 30	M16×2 Tap 30
- T	M16×2 Tap 30	Ø18 Thru
B -	5/8"-11UNC-2B Tap 30	5/8"-11UNC-2B Tap 30
B T	5/8"-11UNC-2B Tap 30	Ø18 Thru

## PERFORMANCE PARAMETERS

OUTPUT TORQUE	TILTING MOMENT TORQUE	HOLDING TORQUE	STATIC AXIAL RATING	STATIC RADIAL RATING	DYNAMIC AXIAL RATING	DYNAMIC RADIAL RATING	GEAR RATIO	TRACKING PRECISION	WEIGHT
12.96 kN.m	142.4 kN.m	58 kN.m	1166 kN	435 kN	280 kN	231 kN	104 : 1	≤ 0.1°	82 kg
9564 lbf.ft	105×10³ lbf.ft	42.8×10³ lbf.ft	262×10³ lbf	97.8×10³ lbf	62.9×10³ lbf	51.9×10³ lbf			181 lb

All dimensions in mm unless otherwise specified

## FRONT

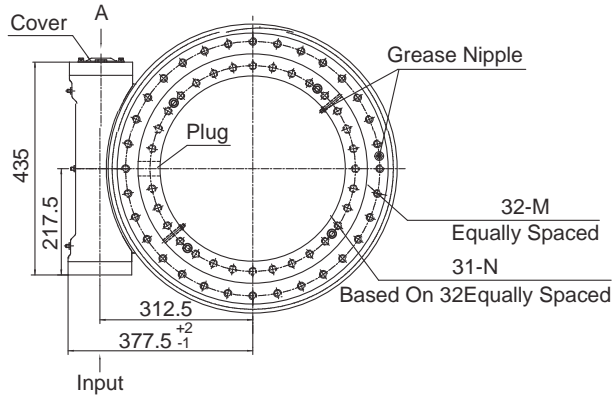

## INPUT

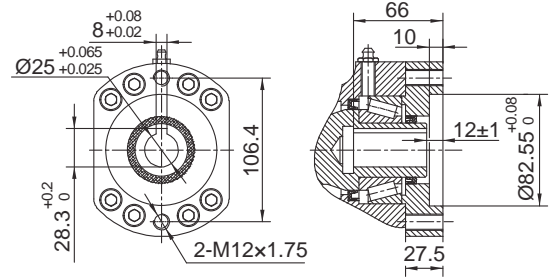

## Ø25

## SIDE

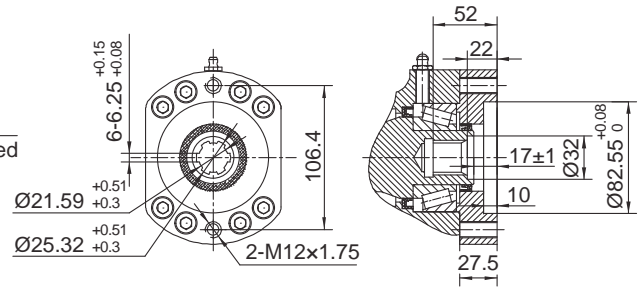
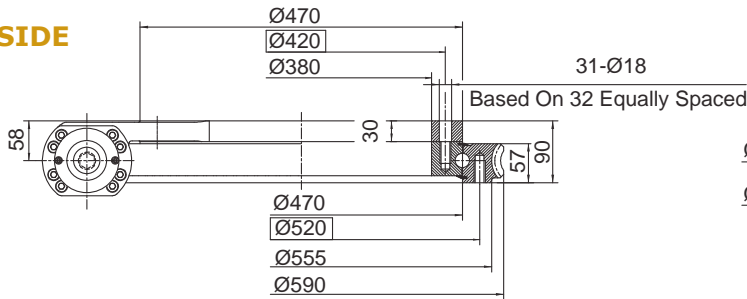

## 6B SPLINE

## MOMENT LOAD CHART

## MOUNTING HOLES OPTION

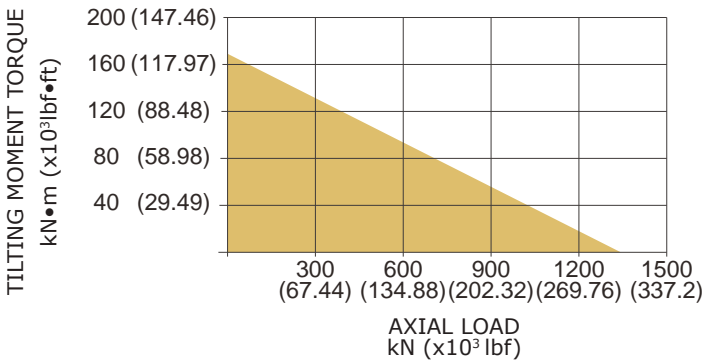

CODE 6&7	M (OUTER RING)	N (INNER RING)
- -	M16x2 Tap 32	M16x2 Tap 32
- T	M16x2 Tap 32	Ø18 Thru
B -	5/8"-11UNC-2B Tap 32	5/8"-11UNC-2B Tap 32
B T	5/8"-11UNC-2B Tap 32	Ø18 Thru

## PERFORMANCE PARAMETERS

OUTPUT TORQUE	TILTING MOMENT TORQUE	HOLDING TORQUE	STATIC AXIAL RATING	STATIC RADIAL RATING	DYNAMIC AXIAL RATING	DYNAMIC RADIAL RATING	GEAR RATIO	TRACKING PRECISION	WEIGHT
18.5 kN.m	170 kN.m	80.1 kN.m	1400 kN	525 kN	290 kN	250 kN	94 : 1	≤ 0.1°	95 kg
13653 lbf.ft	125.5x10 <sup>3</sup> lbf.ft	59.1x10 <sup>3</sup> lbf.ft	314.7x10 <sup>3</sup> lbf	118x10 <sup>3</sup> lbf	65.2x10 <sup>3</sup> lbf	56.2x10 <sup>3</sup> lbf			209 lb

# Series W21 Dimensions and Ratings

All dimensions in mm unless otherwise specified

## FRONT

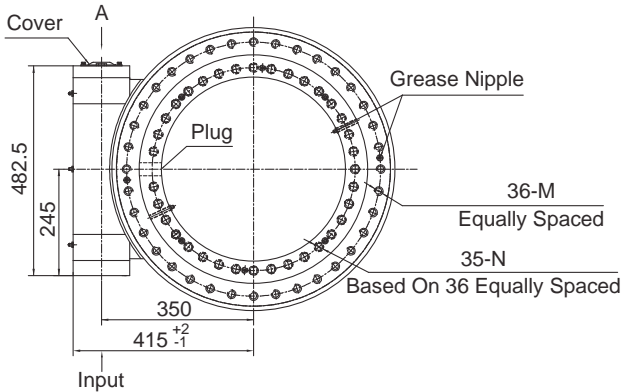

## INPUT

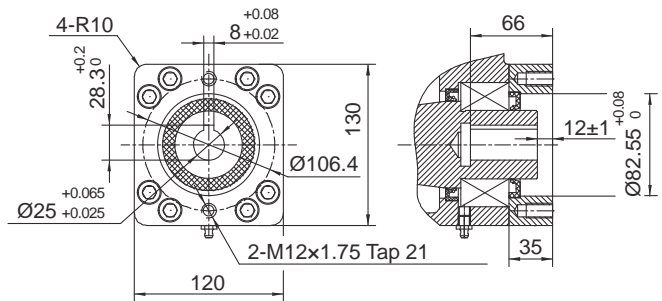

## SIDE

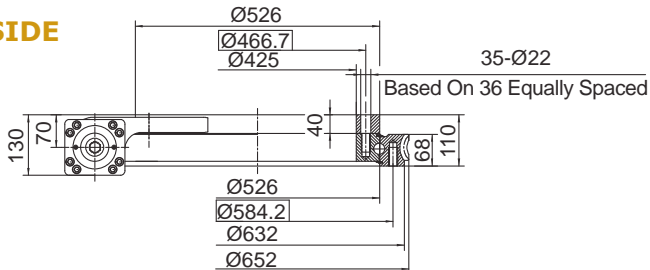

## Ø25

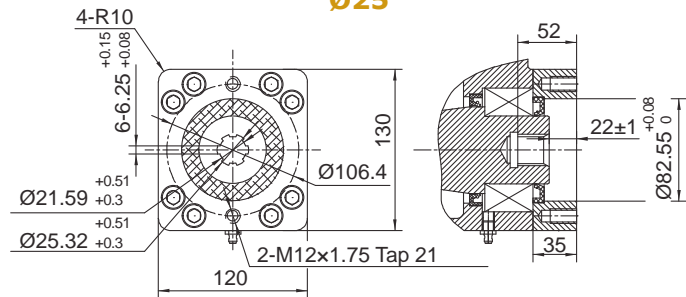

## 6B SPLINE

## MOMENT LOAD CHART

## MOUNTING HOLES OPTION

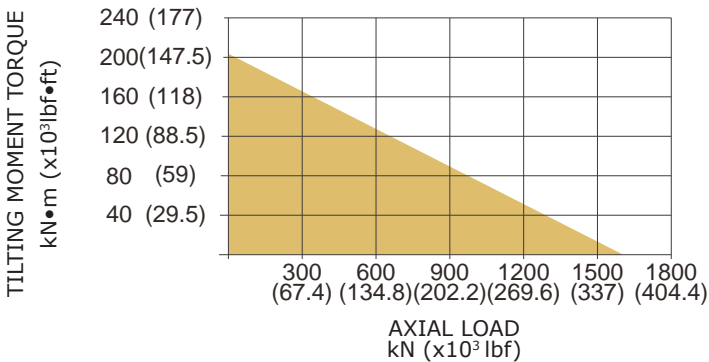

CODE 6&7	M (OUTER RING)	N (INNER RING)
--	M20×2.5 Tap 40	M20×2.5 Tap 40
- T	M20×2.5 Tap 40	Ø18 Thru
B -	3/4"-10UNC-2B Tap 40	3/4"-10UNC-2B Tap 40
B T	3/4"-10UNC-2B Tap 40	Ø22Thru

## PERFORMANCE PARAMETERS

OUTPUT TORQUE	TILTING MOMENT TORQUE	HOLDING TORQUE	STATIC AXIAL RATING	STATIC RADIAL RATING	DYNAMIC AXIAL RATING	DYNAMIC RADIAL RATING	GEAR RATIO	TRACKING PRECISION	WEIGHT
28.7 kN.m	203 kN.m	105.8 kN.m	1598 kN	640 kN	385 kN	335 kN	90 : 1	≤ 0.1°	139 kg
21180 lbf.ft	150×10 <sup>3</sup> lbf.ft	78.1×10 <sup>3</sup> lbf.ft	359×10 <sup>3</sup> lbf	144×10 <sup>3</sup> lbf	87×10 <sup>3</sup> lbf	75×10 <sup>3</sup> lbf			306 lb

All dimensions in mm unless otherwise specified

## FRONT

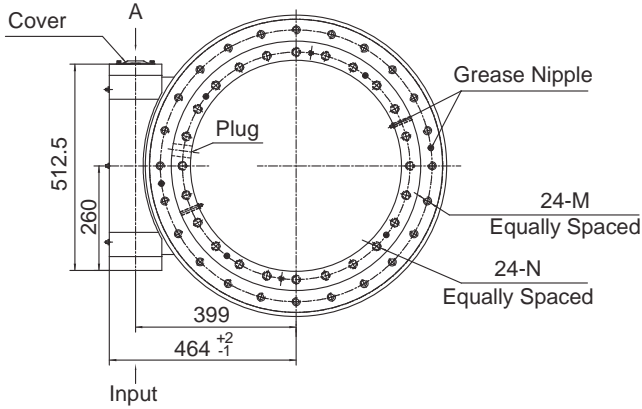

## INPUT

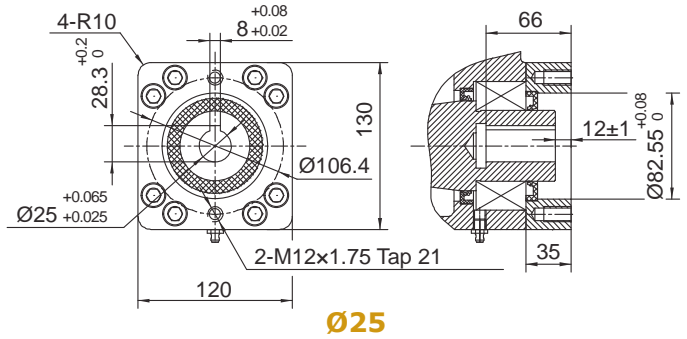

## SIDE

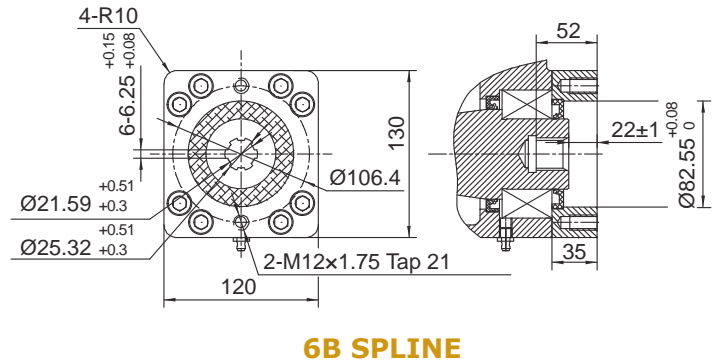
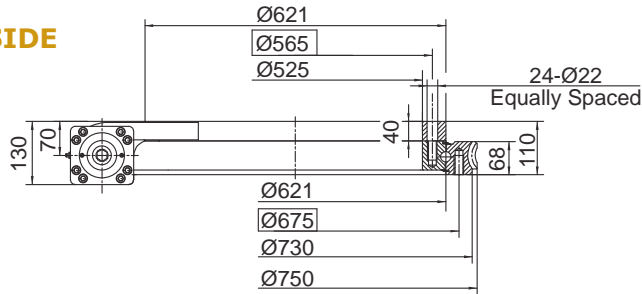

## MOMENT LOAD CHART

## MOUNTING HOLES OPTION

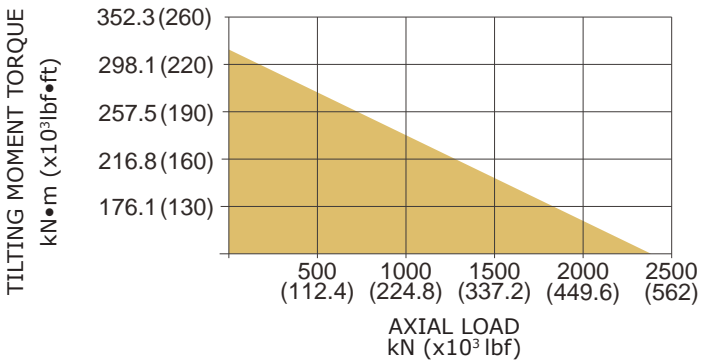

CODE	M (OUTER RING)	N (INNER RING)
6&7	M20x2.5 Tap 40	M20x2.5 Tap 40
- T	M20x2.5 Tap 40	Ø22 Thru
B -	3/4"-10UNC-2B Tap 40	3/4"-10UNC-2B Tap 40
B T	3/4"-10UNC-2B Tap 40	Ø22 Thru

## PERFORMANCE PARAMETERS

OUTPUT TORQUE	TILTING MOMENT TORQUE	HOLDING TORQUE	STATIC AXIAL RATING	STATIC RADIAL RATING	DYNAMIC AXIAL RATING	DYNAMIC RADIAL RATING	GEAR RATIO	TRACKING PRECISION	WEIGHT
34.2 kN.m	310 kN.m	158.3 kN.m	2360 kN	945 kN	590 kN	470 kN	104 : 1	≤ 0.1°	176 kg
25240 lbf.ft	229x10 <sup>3</sup> lbf.ft	117x10 <sup>3</sup> lbf.ft	531x10 <sup>3</sup> lbf	212x10 <sup>3</sup> lbf	133x10 <sup>3</sup> lbf	106x10 <sup>3</sup> lbf			388 lb

All dimensions in mm unless otherwise specified

## FRONT

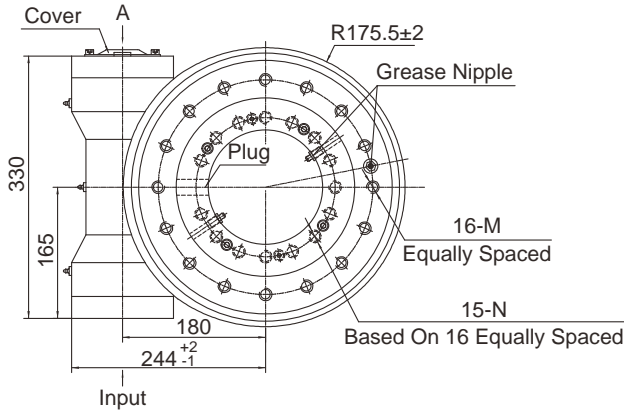

## INPUT

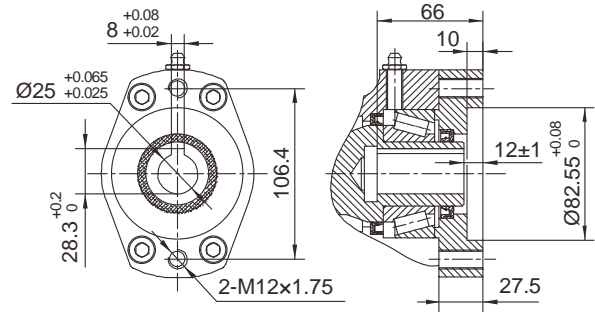

## SIDE

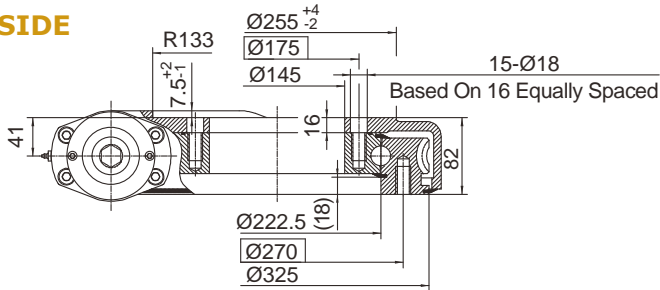

## Ø25

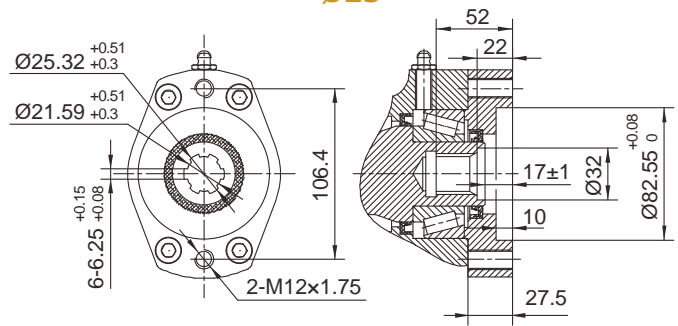

## 6B SPLINE

## MOMENT LOAD CHART

## MOUNTING HOLES OPTION

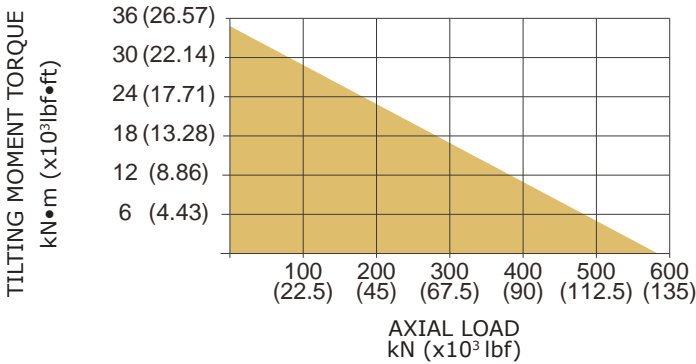

CODE 6&7	M (OUTER RING)	N (INNER RING)
--	M16×2 Tap30	M16×2 Tap 30
- T	M16×2 Tap 30	Ø18 Thru
B -	5/8"-11UNC-2B Tap 30	5/8"-11UNC-2B Tap 30
B T	5/8"-11UNC-2B Tap 30	Ø18 Thru

## PERFORMANCE PARAMETERS

OUTPUT TORQUE	TILTING MOMENT TORQUE	HOLDING TORQUE	STATIC AXIAL RATING	STATIC RADIAL RATING	DYNAMIC AXIAL RATING	DYNAMIC RADIAL RATING	GEAR RATIO	TRACKING PRECISION	WEIGHT
8 kN.m	35.6 kN.m	34.5 kN.m	578 kN	215 kN	136 kN	115 kN	62 : 1	≤ 0.15°	48.5 kg
5904 lbf.ft	26.3×10³ lbf.ft	25.5×10³ lbf.ft	129.9×10³ lbf	48.3×10³ lbf	30.6×10³ lbf	25.9×10³ lbf			107 lb



All dimensions in mm unless otherwise specified

## FRONT

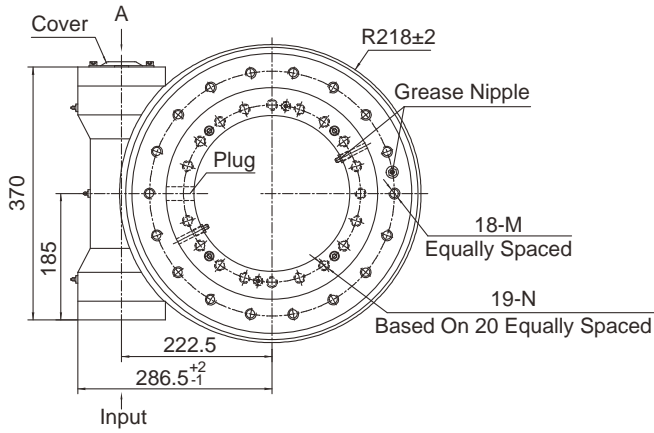

## INPUT

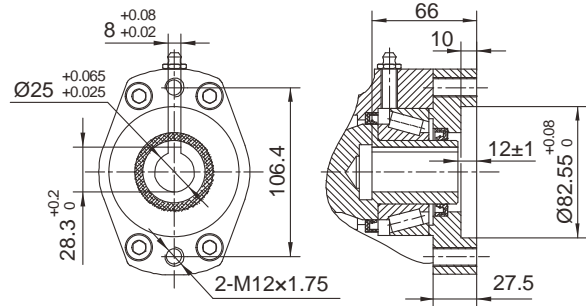

## SIDE

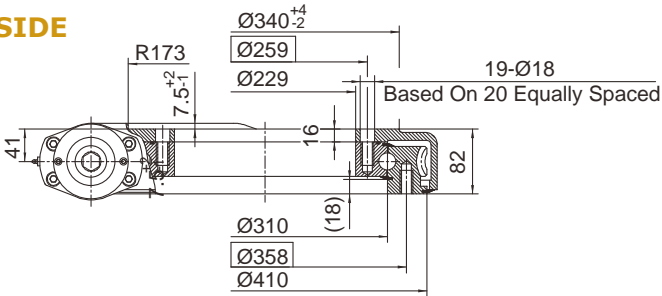

## Ø25

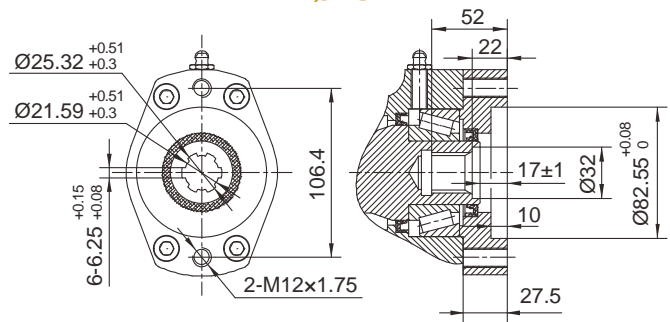

## 6B SPLINE

## MOMENT LOAD CHART

## MOUNTING HOLES OPTION

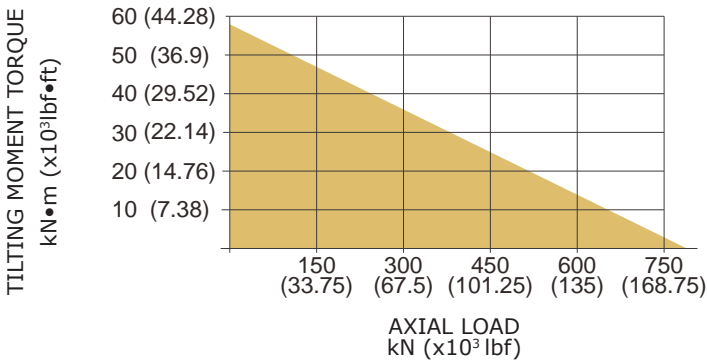

CODE 6&7	M (OUTER RING)	N (INNER RING)
- -	M16×2 Tap 30	M16×2 Tap 30
- T	M16×2 Tap 30	Ø18 Thru
B -	5/8"-11UNC-2B Tap 30	5/8"-11UNC-2B Tap 30
B T	5/8"-11UNC-2B Tap 30	Ø18 Thru

## PERFORMANCE PARAMETERS

OUTPUT TORQUE	TILTING MOMENT TORQUE	HOLDING TORQUE	STATIC AXIAL RATING	STATIC RADIAL RATING	DYNAMIC AXIAL RATING	DYNAMIC RADIAL RATING	GEAR RATIO	TRACKING PRECISION	WEIGHT
9.5 kN.m	57 kN.m	43 kN.m	760 kN	280 kN	190 kN	148 kN	79 : 1	≤ 0.15°	61 kg
7011 lbf.ft	42.1×10³ lbf.ft	32×10³ lbf.ft	171.1×10³ lbf	62.9×10³ lbf	42.7×10³ lbf	33.3×10³ lbf			134 lb

# Series WE14 Dimensions and Ratings

All dimensions in mm unless otherwise specified

## FRONT

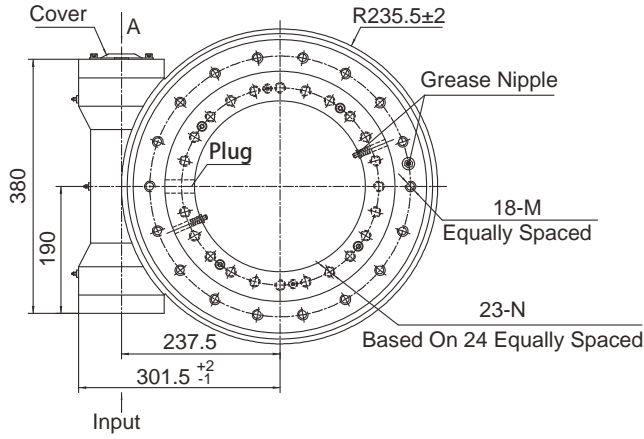

## SIDE

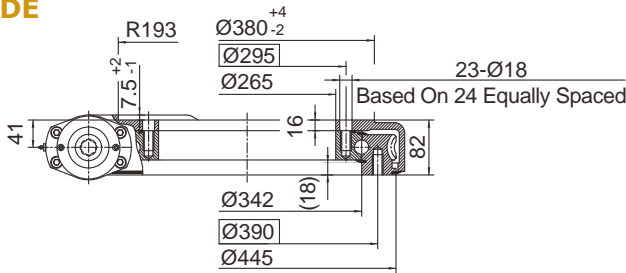

## INPUT

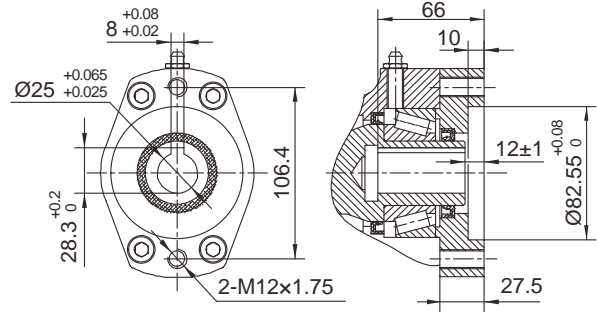

Ø25

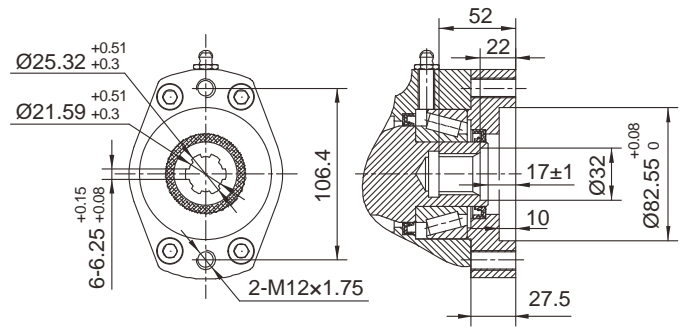

6B SPLINE

## MOMENT LOAD CHART

## MOUNTING HOLES OPTION

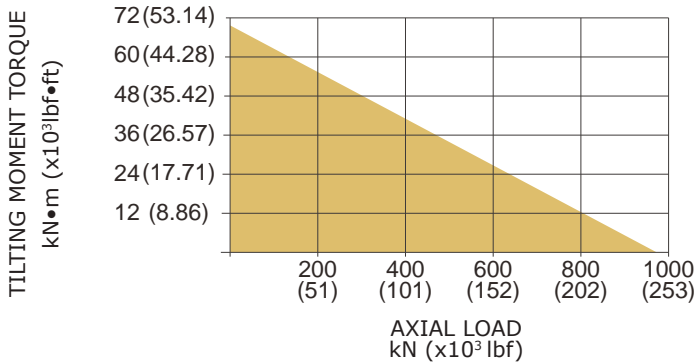

CODE 6&7	M (OUTER RING)	N (INNER RING)
--	M16×2 Tap 30	M16×2 Tap 30
-T	M16×2 Tap 30	Ø18 Thru
B-	5/8"-11UNC-2B Tap 30	5/8"-11UNC-2B Tap 30
BT	5/8"-11UNC-2B Tap 30	Ø18 Thru

## PERFORMANCE PARAMETERS

OUTPUT TORQUE	TILTING MOMENT TORQUE	HOLDING TORQUE	STATIC AXIAL RATING	STATIC RADIAL RATING	DYNAMIC AXIAL RATING	DYNAMIC RADIAL RATING	GEAR RATIO	TRACKING PRECISION	WEIGHT
10.8 kN.m	71.2 kN.m	48 kN.m	960 kN	360 kN	230 kN	200 kN	86 : 1	≤ 0.13°	68 kg
7970 lbf.ft	52.6×10³ lbf.ft	35×10³ lbf.ft	215.8×10³ lbf	80.9×10³ lbf	51.7×10³ lbf	44.9×10³ lbf			150 lb

All dimensions in mm unless otherwise specified

## FRONT

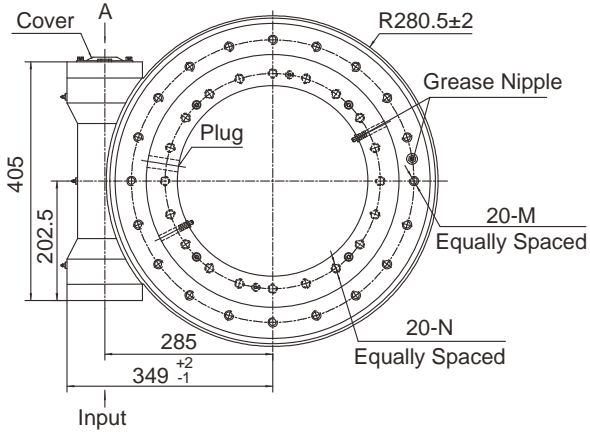

## INPUT

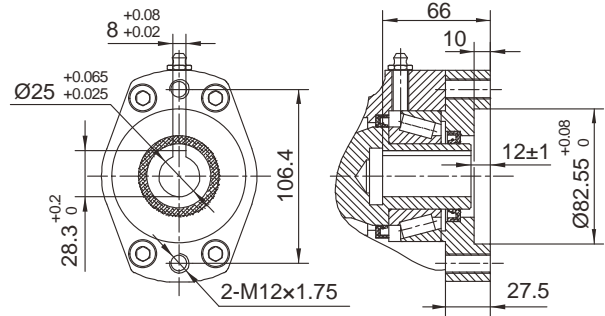

**Ø25**

## SIDE

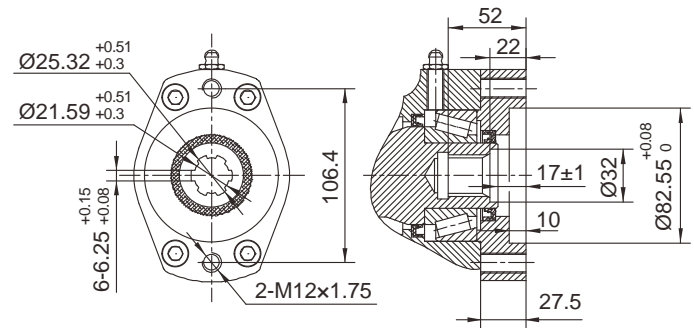
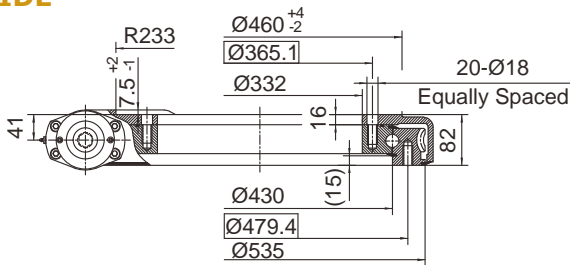

**6B SPLINE**

## MOMENT LOAD CHART

## MOUNTING HOLES OPTION

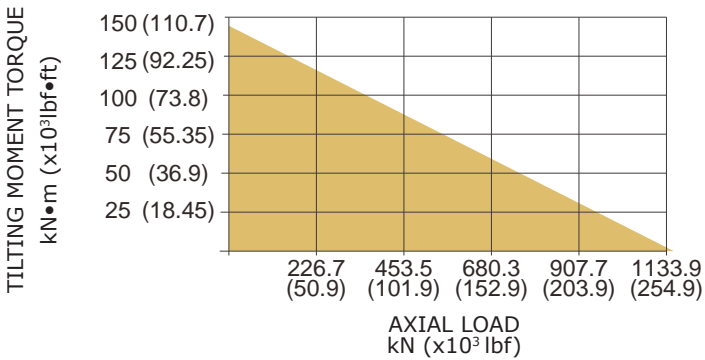

CODE 6&7	M (OUTER RING)	N (INNER RING)
- -	M16×2 Tap 32	M16×2 Tap 32
- T	M16×2 Tap 32	Ø18 Thru
B -	5/8"-11UNC-2B Tap 32	5/8"-11UNC-2B Tap 32
B T	5/8"-11UNC-2B Tap 32	Ø18 Thru

## PERFORMANCE PARAMETERS

OUTPUT TORQUE	TILTING MOMENT TORQUE	HOLDING TORQUE	STATIC AXIAL RATING	STATIC RADIAL RATING	DYNAMIC AXIAL RATING	DYNAMIC RADIAL RATING	GEAR RATIO	TRACKING PRECISION	WEIGHT
12.96 kN.m	142.4 kN.m	58 kN.m	1166 kN	435 kN	280 kN	231 kN	104 : 1	≤ 0.1°	90 kg
9564 lbf.ft	105×10³ lbf.ft	42.8×10³ lbf.ft	262×10³ lbf	97.8×10³ lbf	62.9×10³ lbf	51.9×10³ lbf			198 lb

All dimensions in mm unless otherwise specified

## FRONT

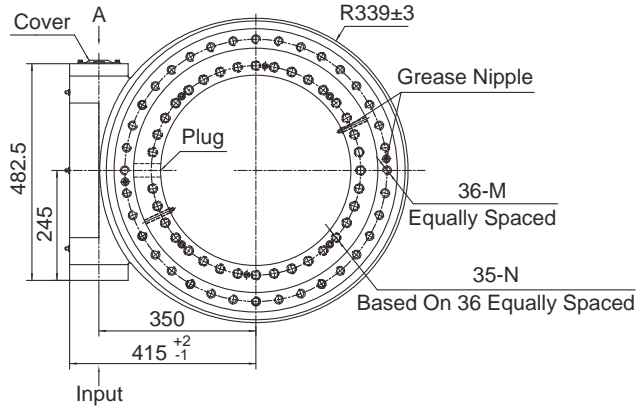

## INPUT

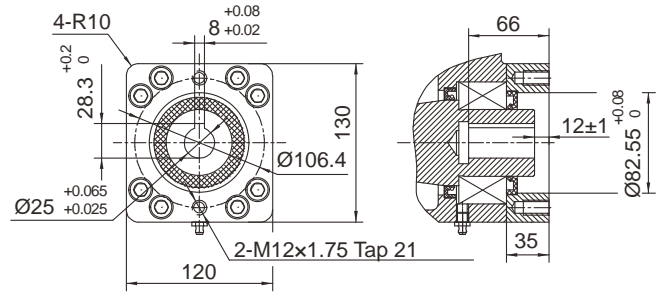

## SIDE

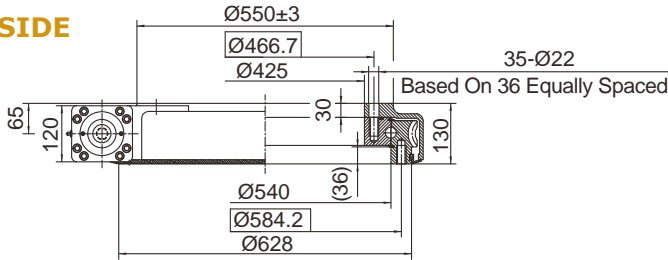

## Ø25

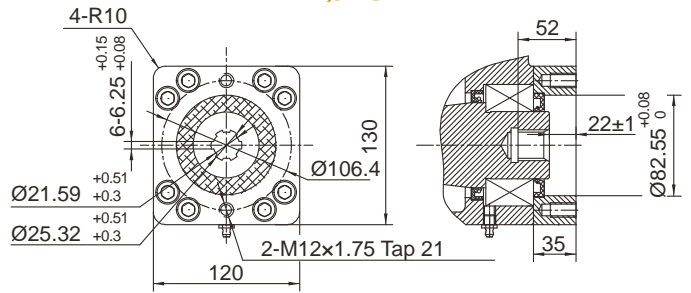

## 6B SPLINE

## MOMENT LOAD CHART

## MOUNTING HOLES OPTION

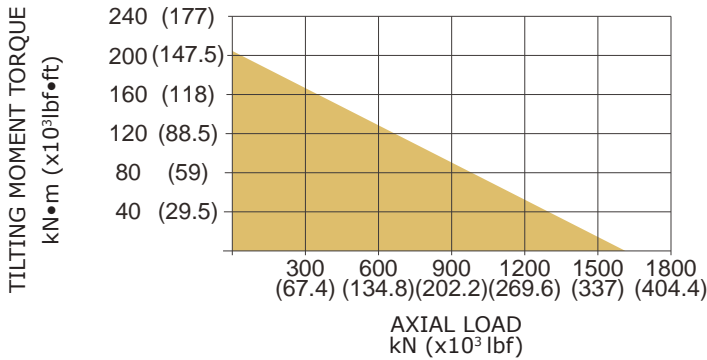

CODE	M (OUTER RING)	N (INNER RING)
6&7	M20×2.5 Tap 40	M20×2.5 Tap 40
- T	M20×2.5 Tap 40	Ø22 Thru
B -	3/4"-10UNC-2B Tap 40	3/4"-10UNC-2B Tap 40
B T	3/4"-10UNC-2B Tap 40	Ø22 Thru

## PERFORMANCE PARAMETERS

OUTPUT TORQUE	TILTING MOMENT TORQUE	HOLDING TORQUE	STATIC AXIAL RATING	STATIC RADIAL RATING	DYNAMIC AXIAL RATING	DYNAMIC RADIAL RATING	GEAR RATIO	TRACKING PRECISION	WEIGHT
28.7 kN.m	203 kN.m	105.8 kN.m	1598 kN	640 kN	385 kN	335 kN	90 : 1	≤ 0.1°	169 kg
21180 lbf.ft	150×10 <sup>3</sup> lbf.ft	78.1×10 <sup>3</sup> lbf.ft	359×10 <sup>3</sup> lbf	144×10 <sup>3</sup> lbf	87×10 <sup>3</sup> lbf	75×10 <sup>3</sup> lbf			373 lb

All dimensions in mm unless otherwise specified

## FRONT

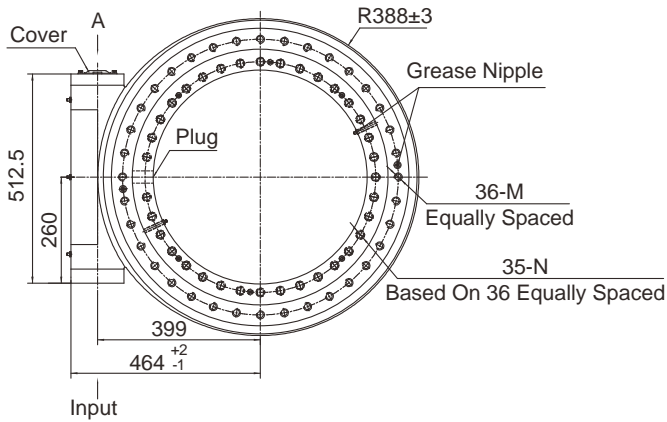

## INPUT

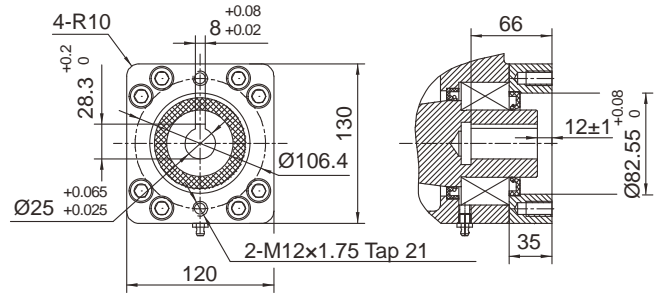

## SIDE

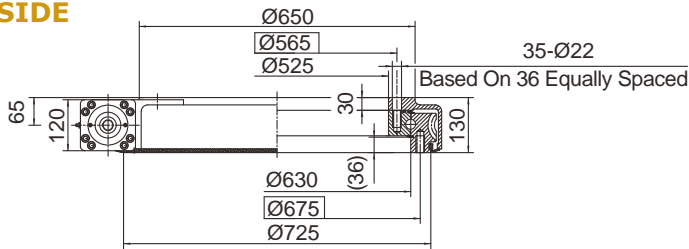

## Ø25

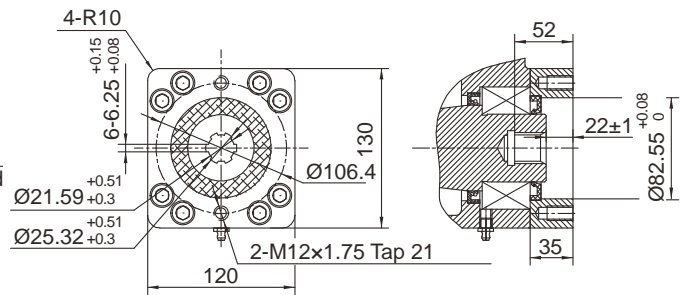

## 6B SPLINE

## MOMENT LOAD CHART

## MOUNTING HOLES OPTION

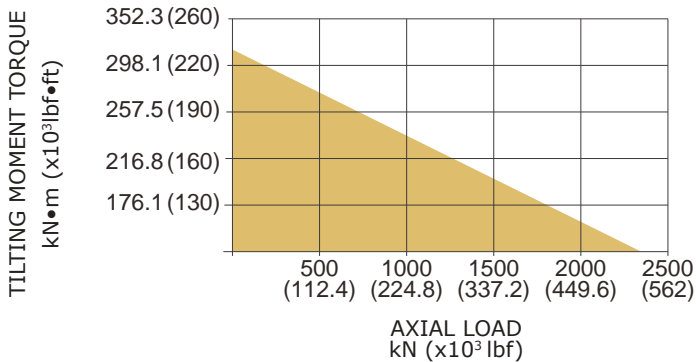

CODE 6&7	M (OUTER RING)	N (INNER RING)
- -	M20×2.5 Tap 40	M20×2.5 Tap 40
- T	M20×2.5 Tap 40	Ø22 Thru
B -	3/4"-10UNC-2B Tap 40	3/4"-10UNC-2B Tap 40
B T	3/4"-10UNC-2B Tap 40	Ø22 Thru

## PERFORMANCE PARAMETERS

OUTPUT TORQUE	TILTING MOMENT TORQUE	HOLDING TORQUE	STATIC AXIAL RATING	STATIC RADIAL RATING	DYNAMIC AXIAL RATING	DYNAMIC RADIAL RATING	GEAR RATIO	TRACKING PRECISION	WEIGHT
34.2 kN.m	310 kN.m	158.3 kN.m	2360 kN	945 kN	590 kN	470 kN	104 : 1	≤ 0.1°	199 kg
25240 lbf.ft	229×10 <sup>3</sup> lbf.ft	117×10 <sup>3</sup> lbf.ft	531×10 <sup>3</sup> lbf	212×10 <sup>3</sup> lbf	133×10 <sup>3</sup> lbf	106×10 <sup>3</sup> lbf			439 lb

# Series WE28 Dimensions and Ratings

All dimensions in mm unless otherwise specified

## FRONT

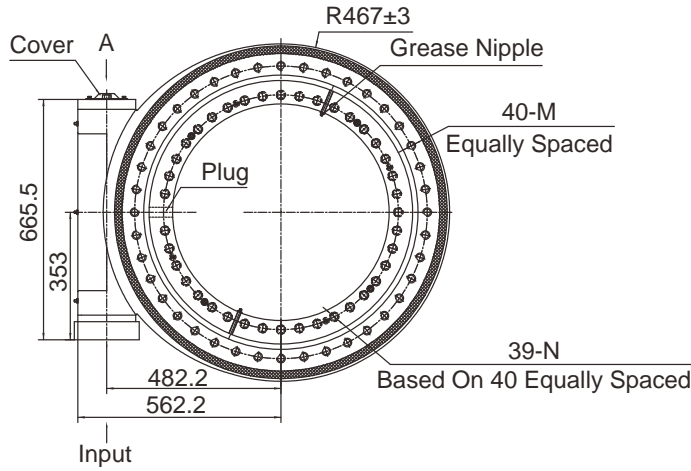

## INPUT

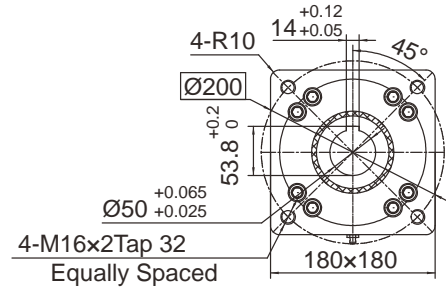

## SIDE

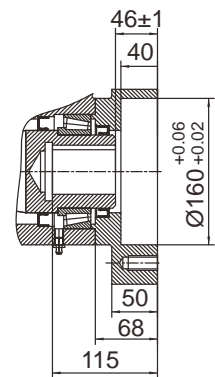
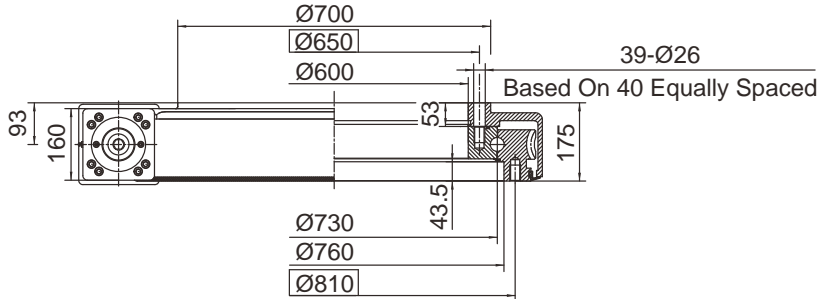

## MOMENT LOAD CHART

## MOUNTING HOLES OPTION

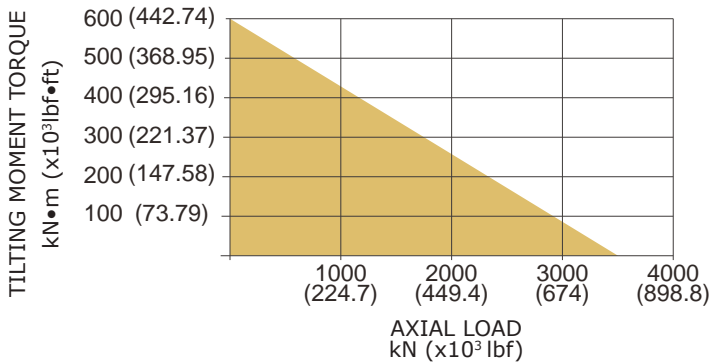

CODE 6&7	M (OUTER RING)	N (INNER RING)
--	M24×3 Tap 36	M24×3 Tap 36
- T	M24×3 Tap 36	Ø26 Thru
B -	7/8"-9UNC-2B Tap 36	7/8"-9UNC-2B Tap 36
B T	7/8"-9UNC-2B Tap 36	Ø26 Thru

## PERFORMANCE PARAMETERS

OUTPUT TORQUE	TILTING MOMENT TORQUE	HOLDING TORQUE	STATIC AXIAL RATING	STATIC RADIAL RATING	DYNAMIC AXIAL RATING	DYNAMIC RADIAL RATING	GEAR RATIO	TRACKING PRECISION	WEIGHT
40 kN.m	600 kN.m	250 kN.m	3400 kN	1360 kN	850 kN	680 kN	110 : 1	≤ 0.15°	403 kg
29516 lbf.ft	443×10 <sup>3</sup> lbf.ft	184×10 <sup>3</sup> lbf.ft	764×10 <sup>3</sup> lbf	306×10 <sup>3</sup> lbf	191×10 <sup>3</sup> lbf	152.8×10 <sup>3</sup> lbf			888 lb

All dimensions in mm unless otherwise specified

## FRONT

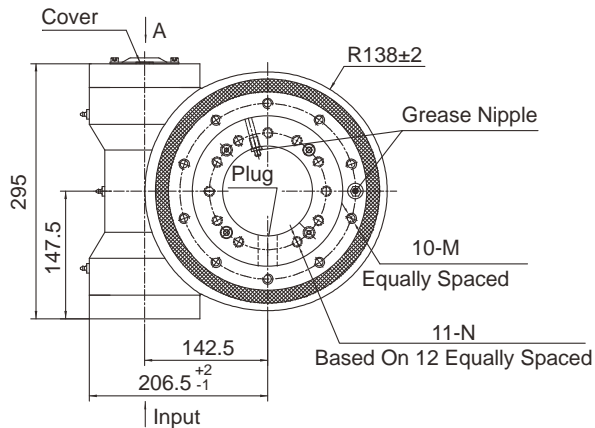

## INPUT

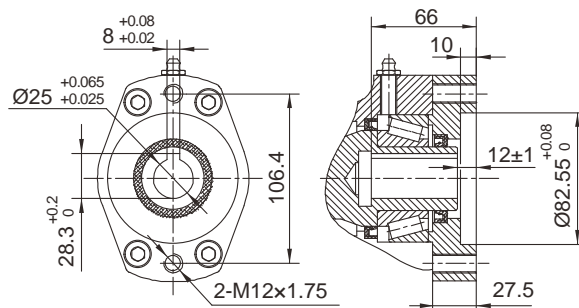

## SIDE

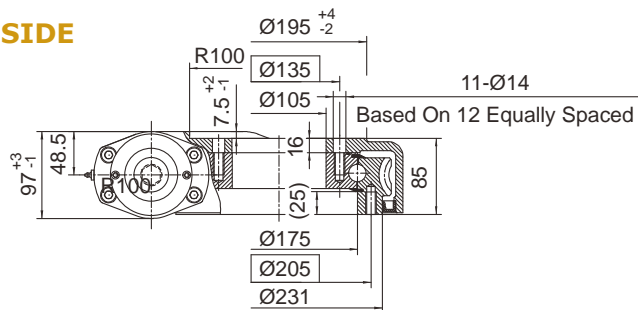

## Ø25

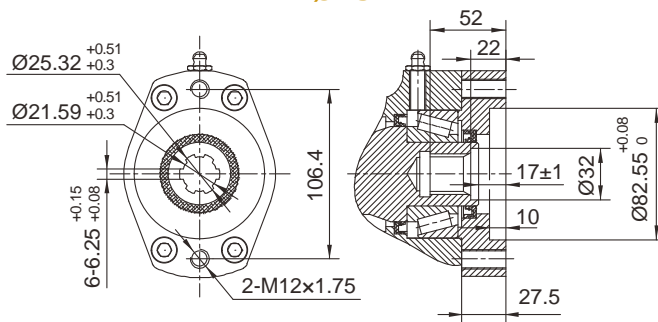

## 6B SPLINE

## MOMENT LOAD CHART

## MOUNTING HOLES OPTION

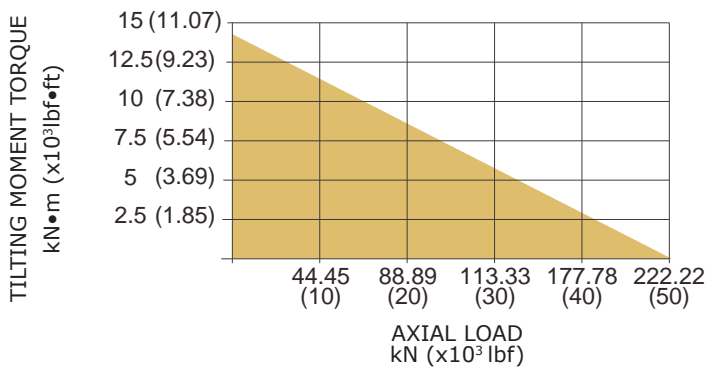

CODE 6&7	M (OUTER RING)	N (INNER RING)
--	M12×1.75 Tap 25	M12×1.75 Tap 25
- T	M12×1.75 Tap 25	Ø14 Thru
B -	1/2"-13UNC-2B Tap 25	1/2"-13UNC-2B Tap 25
B T	1/2"-13UNC-2B Tap 25	Ø14 Thru

## PERFORMANCE PARAMETERS

OUTPUT TORQUE	TILTING MOMENT TORQUE	HOLDING TORQUE	STATIC AXIAL RATING	STATIC RADIAL RATING	DYNAMIC AXIAL RATING	DYNAMIC RADIAL RATING	GEAR RATIO	TRACKING PRECISION	WEIGHT
3.5 kN.m	14.2 kN.m	20 kN.m	220 kN	90 kN	63 kN	48 kN	47 : 1	≤ 0.15°	35 kg
2583 lbf.ft	10.5×10 <sup>3</sup> lbf.ft	14.8×10 <sup>3</sup> lbf.ft	49.5×10 <sup>3</sup> lbf	20.2×10 <sup>3</sup> lbf	14.2×10 <sup>3</sup> lbf	10.8×10 <sup>3</sup> lbf			77 lb



All dimensions in mm unless otherwise specified

## FRONT

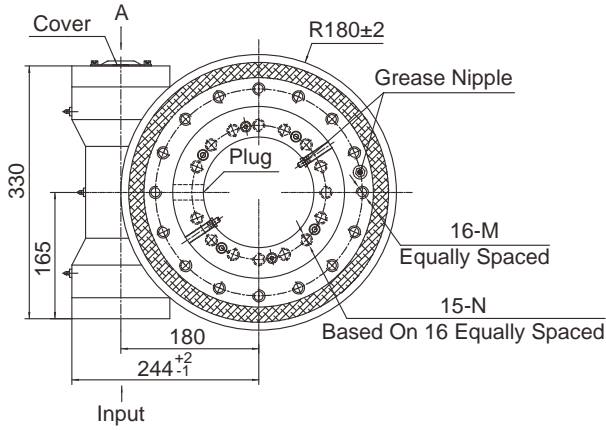

## INPUT

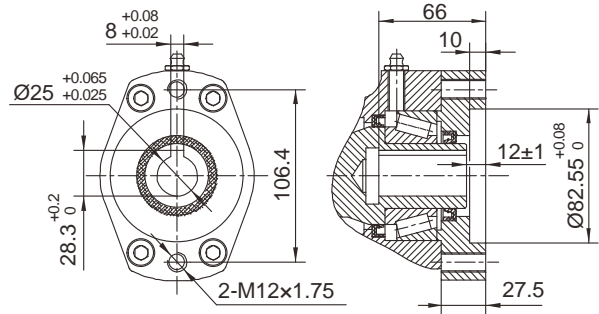

Ø25

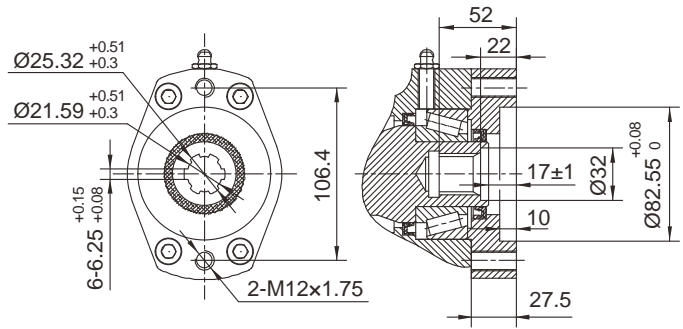

6B SPLINE

## SIDE

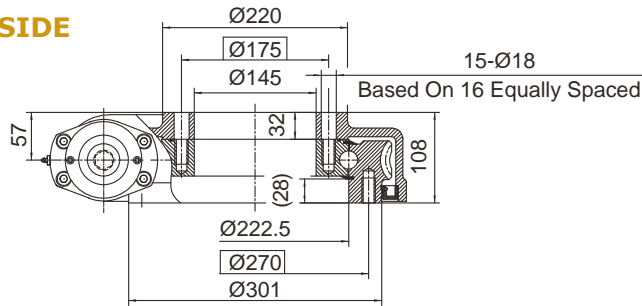

## MOMENT LOAD CHART

## MOUNTING HOLES OPTION

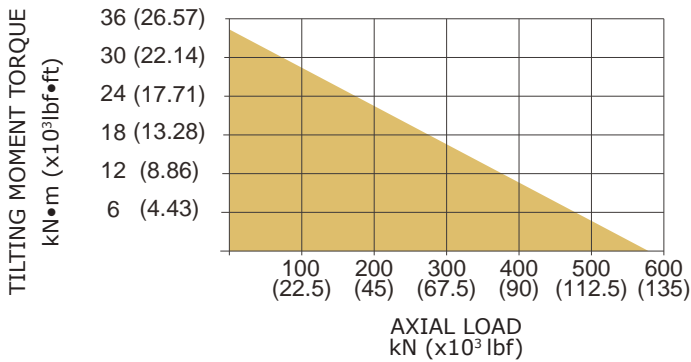

CODE	M (OUTER RING)	N (INNER RING)
6&7		
- -	M16×2 Tap 30	M16×2 Tap 30
- T	M16×2 Tap 30	Ø18 Thru
B -	5/8"-11UNC-2B Tap 30	5/8"-11UNC-2B Tap 30
B T	5/8"-11UNC-2B Tap 30	Ø18 Thru

## PERFORMANCE PARAMETERS

OUTPUT TORQUE	TILTING MOMENT TORQUE	HOLDING TORQUE	STATIC AXIAL RATING	STATIC RADIAL RATING	DYNAMIC AXIAL RATING	DYNAMIC RADIAL RATING	GEAR RATIO	TRACKING PRECISION	WEIGHT
8 kN.m	35.6 kN.m	34.5 kN.m	578 kN	215 kN	136 kN	115 kN	62 : 1	≤ 0.15°	53 kg
5904 lbf.ft	26.3×10 <sup>3</sup> lbf.ft	25.5×10 <sup>3</sup> lbf.ft	129.9×10 <sup>3</sup> lbf	48.3×10 <sup>3</sup> lbf	30.6×10 <sup>3</sup> lbf	25.9×10 <sup>3</sup> lbf			117 lb

All dimensions in mm unless otherwise specified

## FRONT

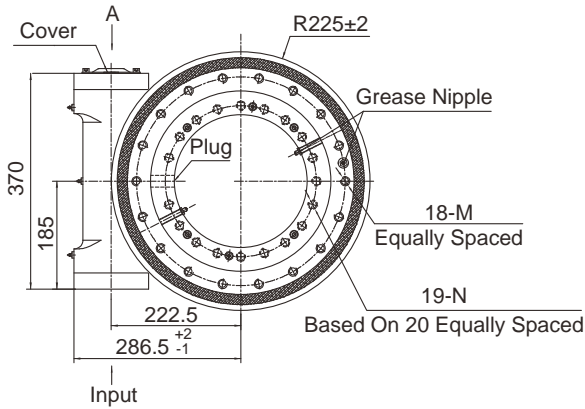

## INPUT

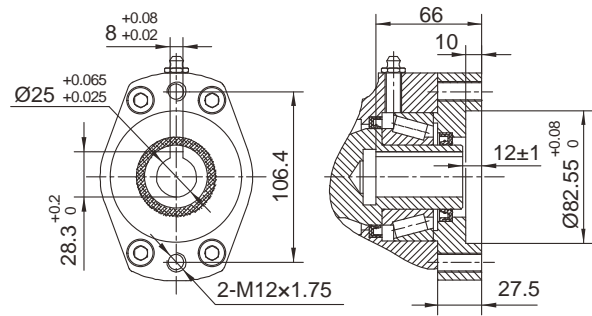

## SIDE

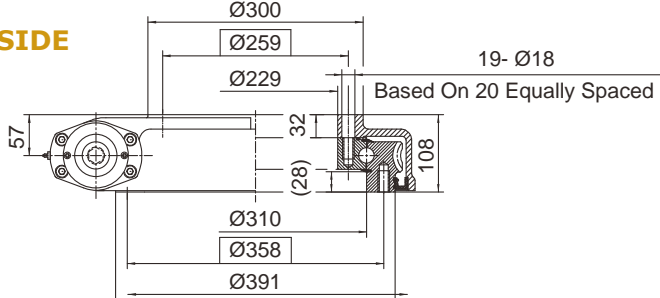

## Ø25

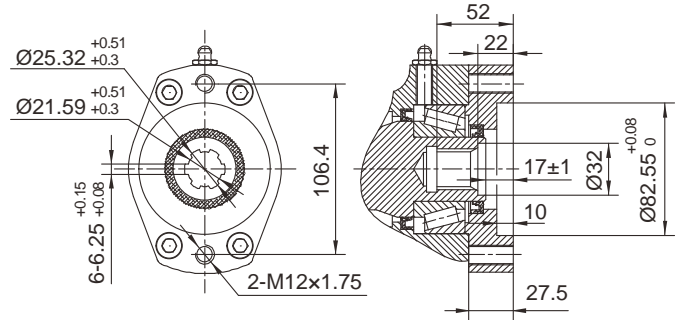

## 6B SPLINE

## MOMENT LOAD CHART

## MOUNTING HOLES OPTION

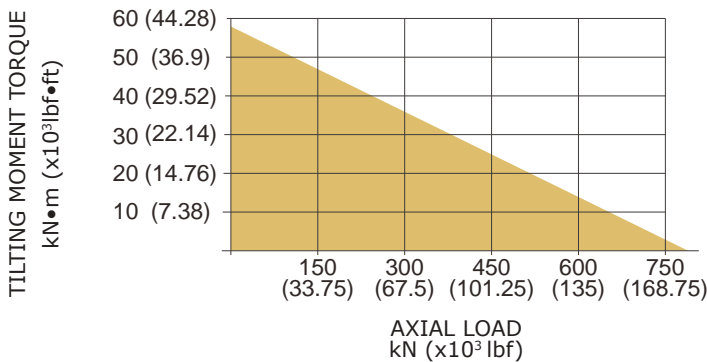

CODE 6&7	M (OUTER RING)	N (INNER RING)
- -	M16×2 Tap 30	M16×2 Tap 30
- T	M16×2 Tap 30	Ø18 Thru
B -	5/8"-11UNC-2B Tap 30	5/8"-11UNC-2B Tap 30
B T	5/8"-11UNC-2B Tap 30	Ø18 Thru

## PERFORMANCE PARAMETERS

OUTPUT TORQUE	TILTING MOMENT TORQUE	HOLDING TORQUE	STATIC AXIAL RATING	STATIC RADIAL RATING	DYNAMIC AXIAL RATING	DYNAMIC RADIAL RATING	GEAR RATIO	TRACKING PRECISION	WEIGHT
9.5 kN.m	57 kN.m	43 kN.m	760 kN	280 kN	190 kN	148 kN	79 : 1	≤ 0.15°	66.8 kg
7011 lbf.ft	42.1×10³ lbf.ft	32×10³ lbf.ft	171.1×10³ lbf	62.9×10³ lbf	42.7×10³ lbf	33.3×10³ lbf			147 lb

# Series WEA14 Dimensions and Ratings

All dimensions in mm unless otherwise specified

## FRONT

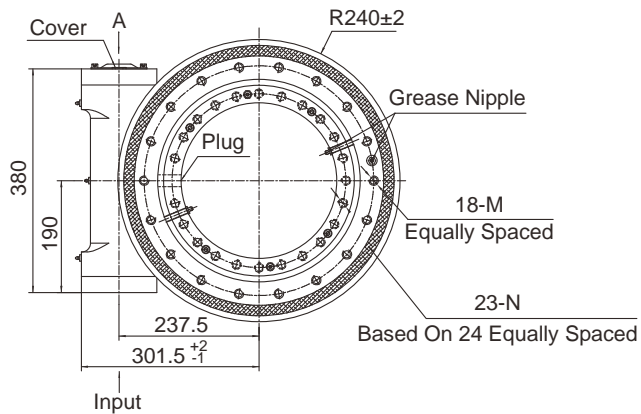

## INPUT

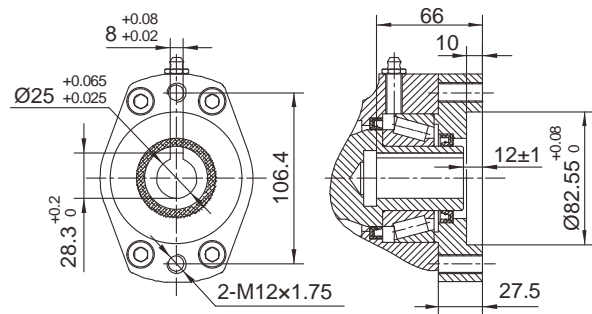

## SIDE

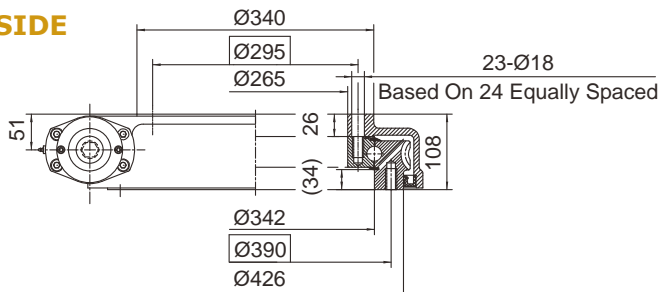

## Ø25

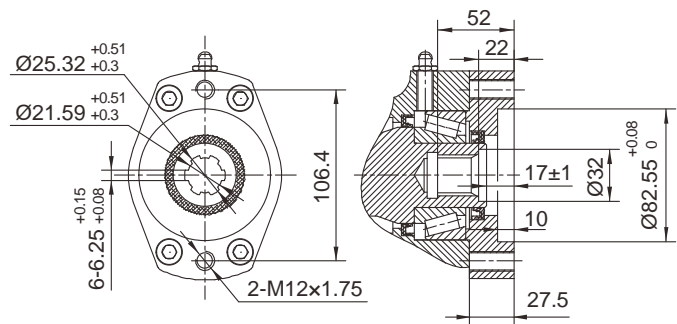

## 6B SPLINE

## MOMENT LOAD CHART

## MOUNTING HOLES OPTION

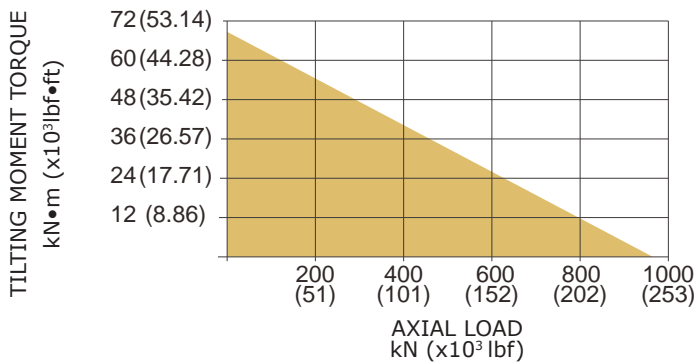

CODE	M (OUTER RING)	N (INNER RING)
6&7	M16×2 Tap 30	M16×2 Tap 30
-	M16×2 Tap 30	M16×2 Tap 30
- T	M16×2 Tap 30	Ø18 Thru
B -	5/8"-11UNC-2B Tap 30	5/8"-11UNC-2B Tap 30
B T	5/8"-11UNC-2B Tap 30	Ø18 Thru

## PERFORMANCE PARAMETERS

OUTPUT TORQUE	TILTING MOMENT TORQUE	HOLDING TORQUE	STATIC AXIAL RATING	STATIC RADIAL RATING	DYNAMIC AXIAL RATING	DYNAMIC RADIAL RATING	GEAR RATIO	TRACKING PRECISION	WEIGHT
10.8 kN.m	71.2 kN.m	48 kN.m	960 kN	360 kN	230 kN	200 kN	86 : 1	≤ 0.13°	75 kg
7970 lbf.ft	52.6×10³ lbf.ft	35×10³ lbf.ft	215.8×10³ lbf	80.9×10³ lbf	51.7×10³ lbf	44.9×10³ lbf			165 lb

All dimensions in mm unless otherwise specified

## FRONT

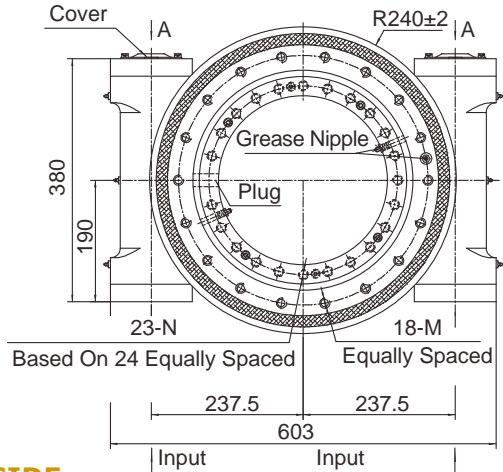

## SIDE

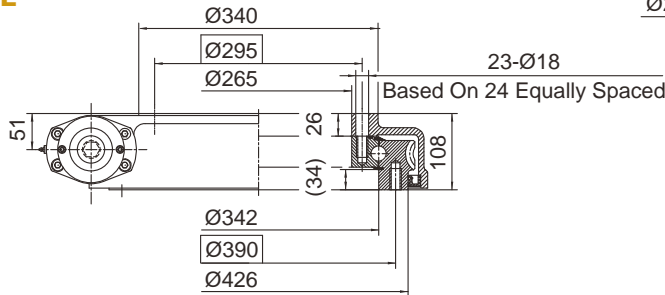

## INPUT

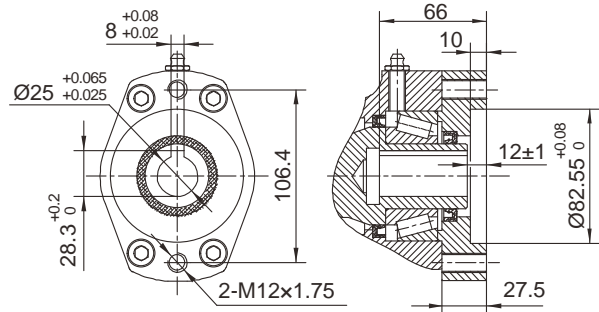

## Ø25

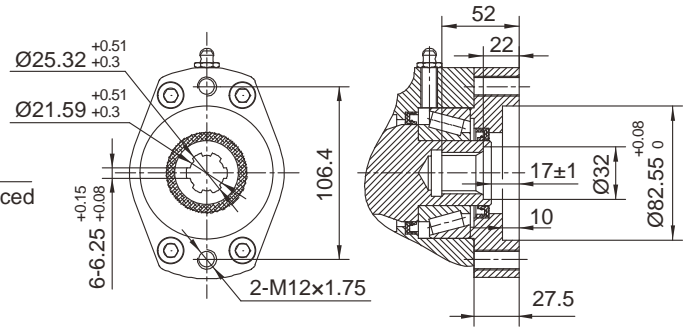

## 6B SPLINE

## MOMENT LOAD CHART

## MOUNTING HOLES OPTION

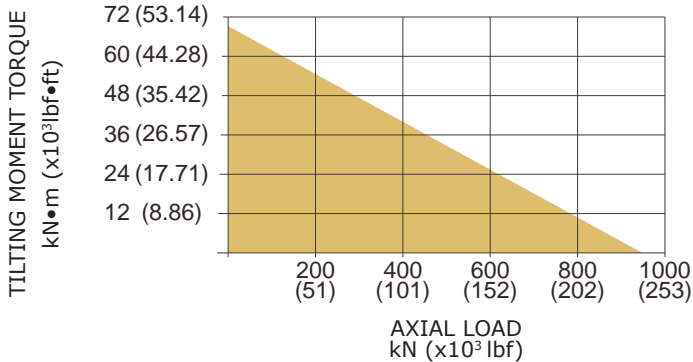

CODE 6&7	M (OUTER RING)	N (INNER RING)
- -	M16×2 Tap 30	M16×2 Tap 30
- T	M16×2 Tap 30	Ø18 Thru
B -	5/8"-11UNC-2B Tap 30	5/8"-11UNC-2B Tap 30
B T	5/8"-11UNC-2B Tap 30	Ø18 Thru

## PERFORMANCE PARAMETERS

OUTPUT TORQUE	TILTING MOMENT TORQUE	HOLDING TORQUE	STATIC AXIAL RATING	STATIC RADIAL RATING	DYNAMIC AXIAL RATING	DYNAMIC RADIAL RATING	GEAR RATIO	TRACKING PRECISION	WEIGHT
16.2 kN.m	71.2 kN.m	82 kN.m	960 kN	360 kN	230 kN	200 kN	86 : 1	≤ 0.15°	90 kg
11956 lbf.ft	52.6×10 <sup>3</sup> lbf.ft	60.5×10 <sup>3</sup> lbf.ft	215.8×10 <sup>3</sup> lbf	80.9×10 <sup>3</sup> lbf	51.7×10 <sup>3</sup> lbf	44.9×10 <sup>3</sup> lbf			198 lb

# Series WEA15 Dimensions and Ratings

All dimensions in mm unless otherwise specified

## FRONT

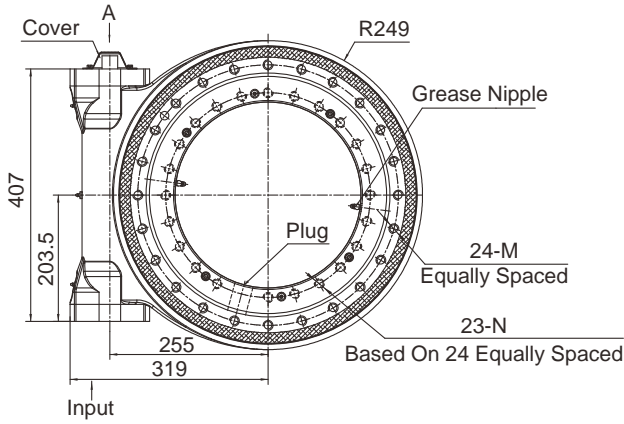

## INPUT

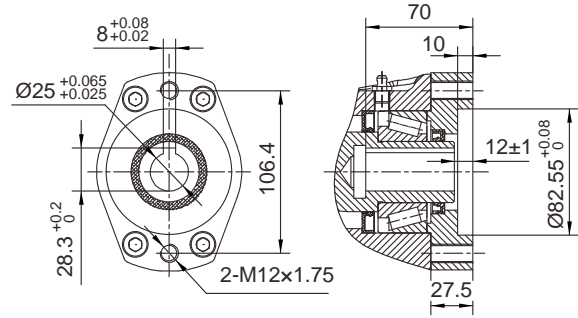

## SIDE

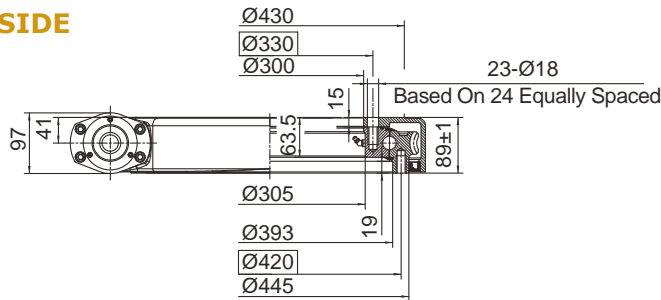

## Ø25

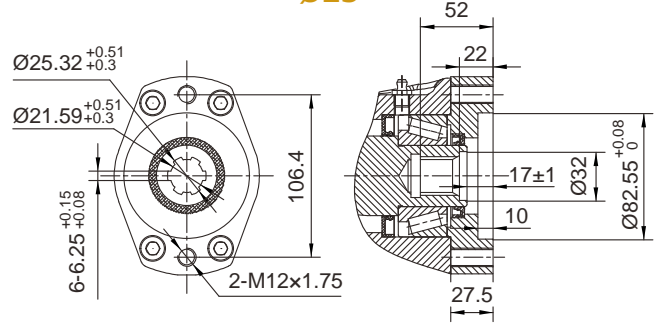

## 6B SPLINE

## MOMENT LOAD CHART

## MOUNTING HOLES OPTION

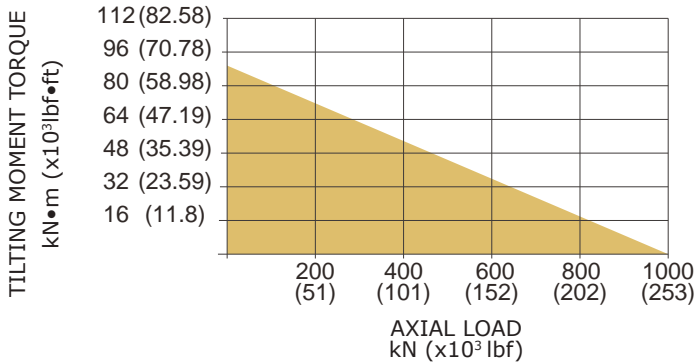

CODE	M (OUTER RING)	N (INNER RING)
6&7	M16×2 Tap 28	N16×2 Tap 28
- T	M16×2 Tap 28	Ø17 Thru
B -	5/8"-11UNC-2B Tap 28	5/8"-11UNC-2B Tap 28
B T	5/8"-11UNC-2B Tap 28	Ø17 Thru

## PERFORMANCE PARAMETERS

OUTPUT TORQUE	TILTING MOMENT TORQUE	HOLDING TORQUE	STATIC AXIAL RATING	STATIC RADIAL RATING	DYNAMIC AXIAL RATING	DYNAMIC RADIAL RATING	GEAR RATIO	TRACKING PRECISION	WEIGHT
12 kN.m	90 kN.m	50 kN.m	1000 kN	400 kN	240 kN	220 kN	92 : 1	≤ 0.1°	66 kg
8856 lbf.ft	66×10 <sup>3</sup> lbf.ft	37×10 <sup>3</sup> lbf.ft	224.8×10 <sup>3</sup> lbf	89.9×10 <sup>3</sup> lbf	54.0×10 <sup>3</sup> lbf	49.5×10 <sup>3</sup> lbf			146 lb

All dimensions in mm unless otherwise specified

## FRONT

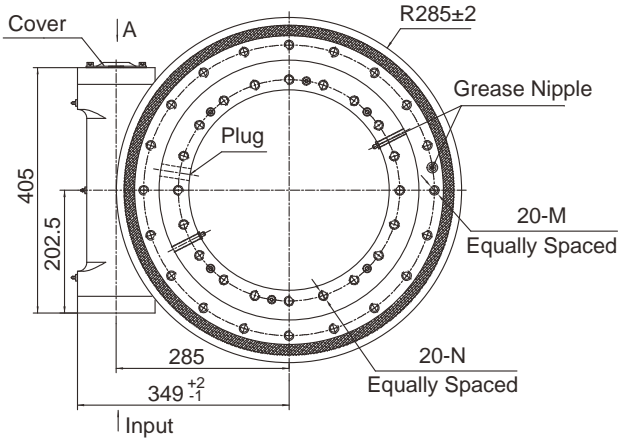

## INPUT

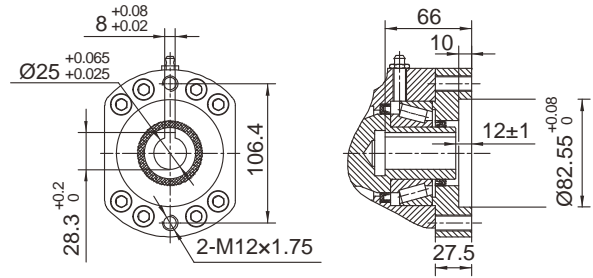

**Ø25**

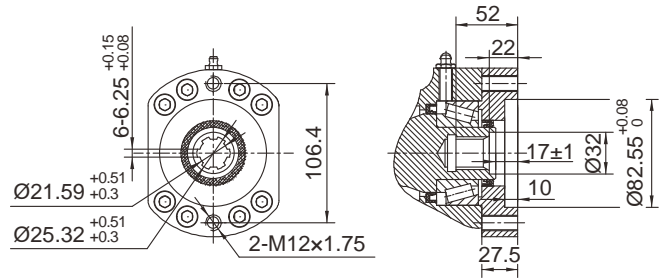

**6B SPLINE**

## SIDE

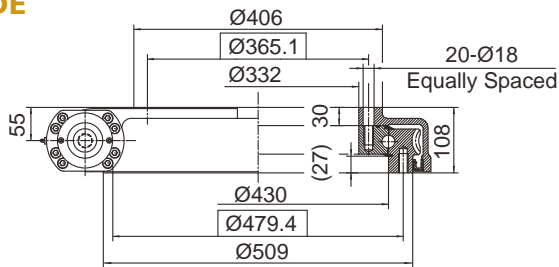

## MOMENT LOAD CHART

## MOUNTING HOLES OPTION

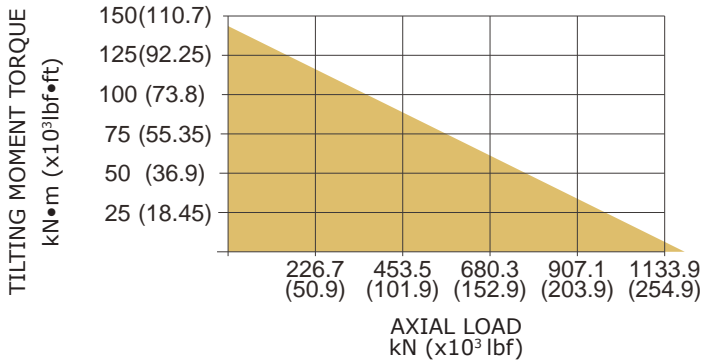

CODE 6&7	M (OUTER RING)	N (INNER RING)
- -	M16×2 Tap 32	M16×2 Tap 32
- T	M16×2 Tap 32	Ø18 Thru
B -	5/8"-11UNC-2B Tap 32	5/8"-11UNC-2B Tap 32
B T	5/8"-11UNC-2B Tap 32	Ø18 Thru

## PERFORMANCE PARAMETERS

OUTPUT TORQUE	TILTING MOMENT TORQUE	HOLDING TORQUE	STATIC AXIAL RATING	STATIC RADIAL RATING	DYNAMIC AXIAL RATING	DYNAMIC RADIAL RATING	GEAR RATIO	TRACKING PRECISION	WEIGHT
12.96 kN.m	142.4 kN.m	72.3 kN.m	1166 kN	435 kN	280 kN	231 kN	104 : 1	≤ 0.1°	96 kg
9564 lbf.ft	105×10³ lbf.ft	53.4×10³ lbf.ft	262×10³ lbf	97.8×10³ lbf	62.9×10³ lbf	51.9×10³ lbf			212 lb

# Series WEA17-2 Dimensions and Ratings

All dimensions in mm unless otherwise specified

## FRONT

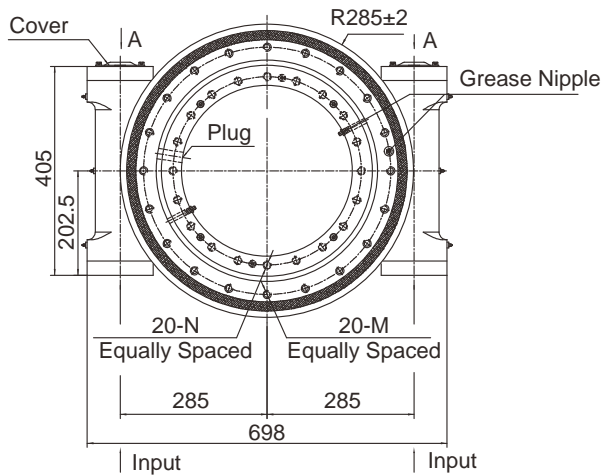

## INPUT

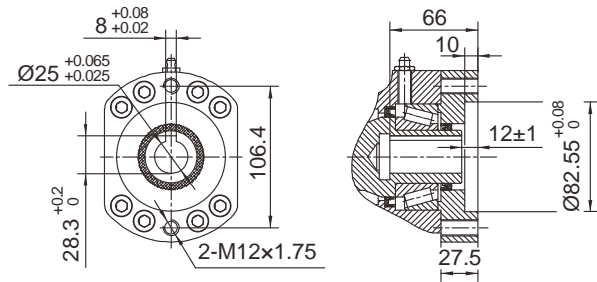

Ø25

## SIDE

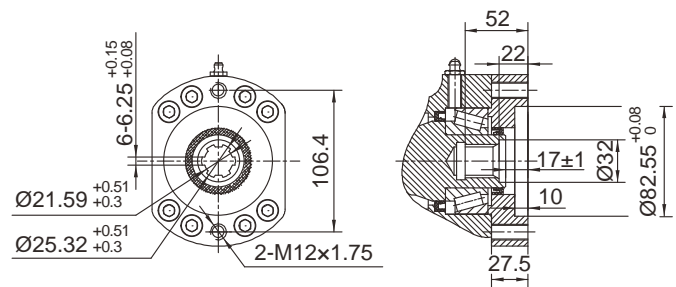
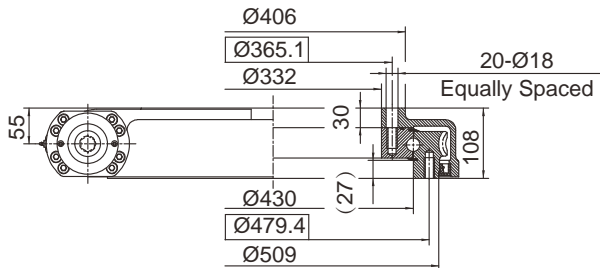

6B SPLINE

## MOMENT LOAD CHART

## MOUNTING HOLES OPTION

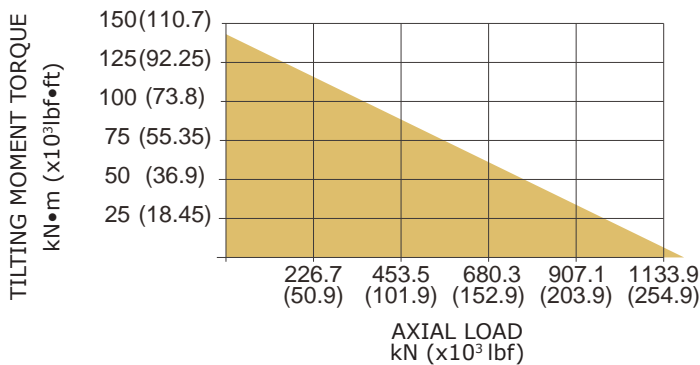

CODE	M (OUTER RING)	N (INNER RING)
6&7		
- -	M16×2 Tap 32	M16×2 Tap 32
- T	M16×2 Tap 32	Ø18 Thru
B -	5/8"-11UNC-2B Tap 32	5/8"-11UNC-2B Tap 32
B T	5/8"-11UNC-2B Tap 32	Ø18 Thru

## PERFORMANCE PARAMETERS

OUTPUT TORQUE	TILTING MOMENT TORQUE	HOLDING TORQUE	STATIC AXIAL RATING	STATIC RADIAL RATING	DYNAMIC AXIAL RATING	DYNAMIC RADIAL RATING	GEAR RATIO	TRACKING PRECISION	WEIGHT
19.44 kN.m	142.4 kN.m	94 kN.m	1166 kN	435 kN	280 kN	231 kN	104 : 1	≤ 0.15°	115 kg
14347 lbf.ft	105.1×10³ lbf.ft	53.4×10³ lbf.ft	262×10³ lbf	97.8×10³ lbf	62.9×10³ lbf	51.9×10³ lbf			254 lb



All dimensions in mm unless otherwise specified

## FRONT

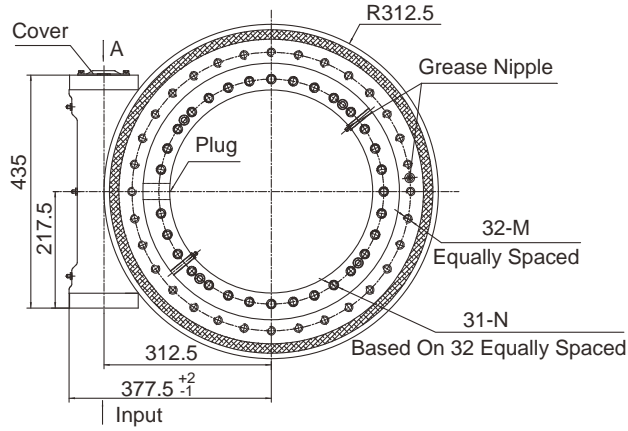

## INPUT

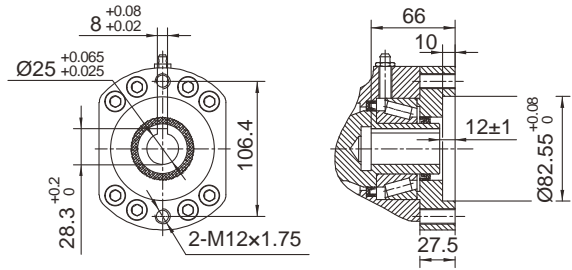

**Ø25**

## SIDE

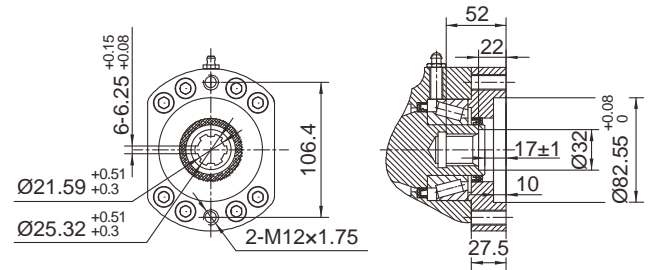
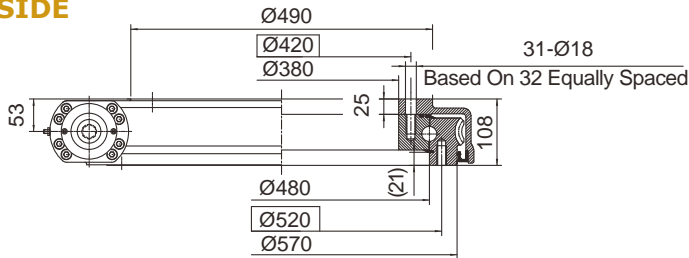

**6B SPLINE**

## MOMENT LOAD CHART

## MOUNTING HOLES OPTION

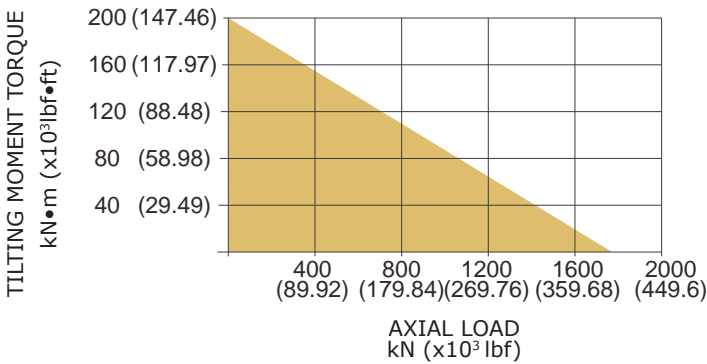

CODE 6&7	M (OUTER RING)	N (INNER RING)
- -	M16×2 Tap 32	M16×2 Tap 32
- T	M16×2 Tap 32	Ø18 Thru
B -	5/8"-11UNC-2B Tap 32	5/8"-11UNC-2B Tap 32
B T	5/8"-11UNC-2B Tap 32	Ø18 Thru

## PERFORMANCE PARAMETERS

OUTPUT TORQUE	TILTING MOMENT TORQUE	HOLDING TORQUE	STATIC AXIAL RATING	STATIC RADIAL RATING	DYNAMIC AXIAL RATING	DYNAMIC RADIAL RATING	GEAR RATIO	TRACKING PRECISION	WEIGHT
18.5 kN.m	196 kN.m	80.1 kN.m	1800 kN	675 kN	290 kN	250 kN	94 : 1	≤ 0.1°	118 kg
13653 lbf.ft	144.6×10³ lbf.ft	59.1×10³ lbf.ft	404.6×10³ lbf	151.7×10³ lbf	65.2×10³ lbf	56.2×10³ lbf			260 lb

# Series WEA21 Dimensions and Ratings

All dimensions in mm unless otherwise specified

## FRONT

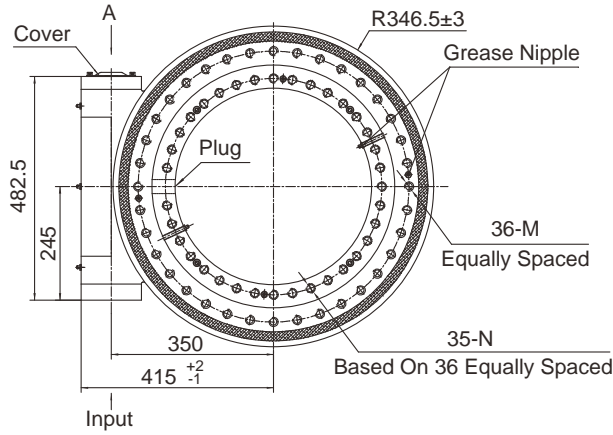

## INPUT

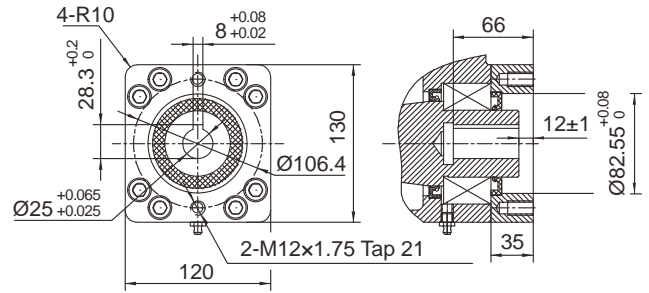

Ø25

## SIDE

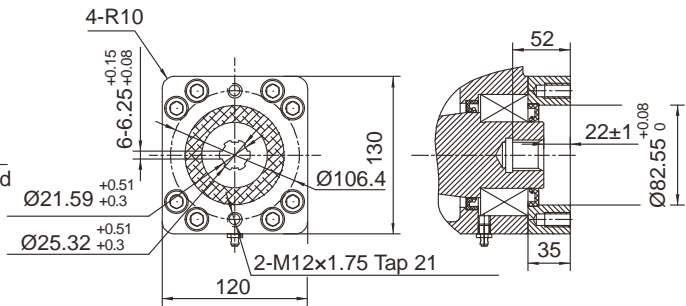
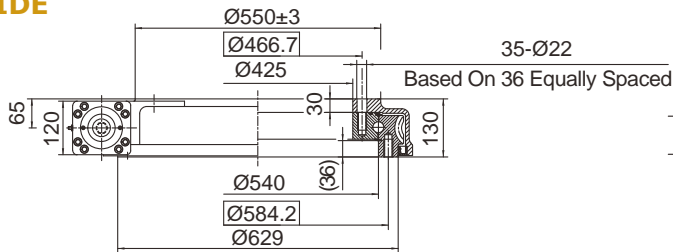

6B SPLINE

## MOMENT LOAD CHART

## MOUNTING HOLES OPTION

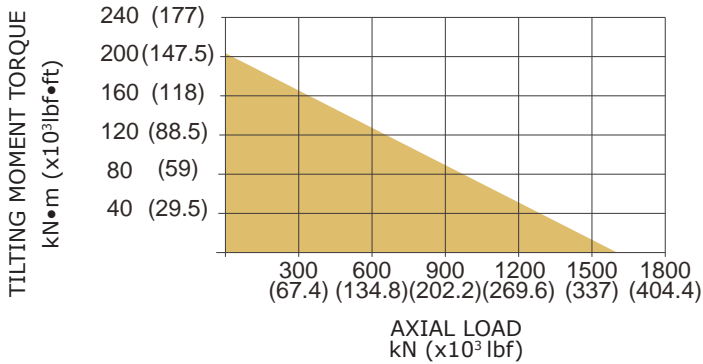

CODE	M (OUTER RING)	N (INNER RING)
6&7	M20×2.5 Tap 40	M20×2.5 Tap 40
- T	M20×2.5 Tap 40	Ø22 Thru
B -	3/4"-10UNC-2B Tap 40	3/4"-10UNC-2B Tap 40
B T	3/4"-10UNC-2B Tap 40	Ø22 Thru

## PERFORMANCE PARAMETERS

OUTPUT TORQUE	TILTING MOMENT TORQUE	HOLDING TORQUE	STATIC AXIAL RATING	STATIC RADIAL RATING	DYNAMIC AXIAL RATING	DYNAMIC RADIAL RATING	GEAR RATIO	TRACKING PRECISION	WEIGHT
28.7 kN.m	203 kN.m	105.8 kN.m	1598 kN	640 kN	385 kN	335 kN	90 : 1	≤ 0.1°	172 kg
21180 lbf.ft	150×10 <sup>3</sup> lbf.ft	78.1×10 <sup>3</sup> lbf.ft	359×10 <sup>3</sup> lbf	144×10 <sup>3</sup> lbf	87×10 <sup>3</sup> lbf	75×10 <sup>3</sup> lbf			379 lb

All dimensions in mm unless otherwise specified

## FRONT

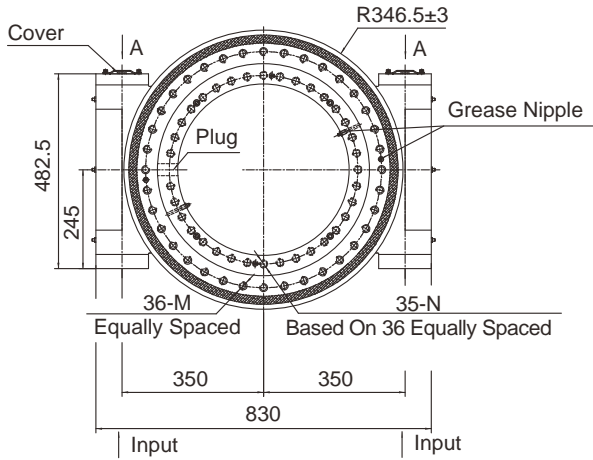

## INPUT

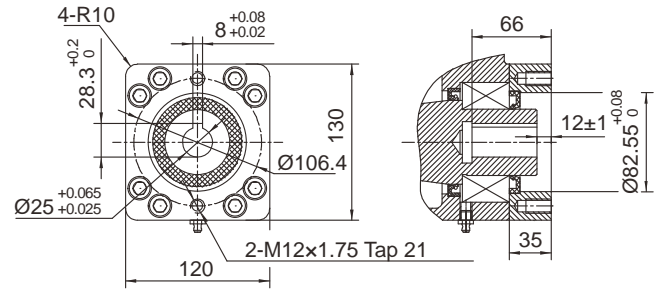

**Ø25**

## SIDE

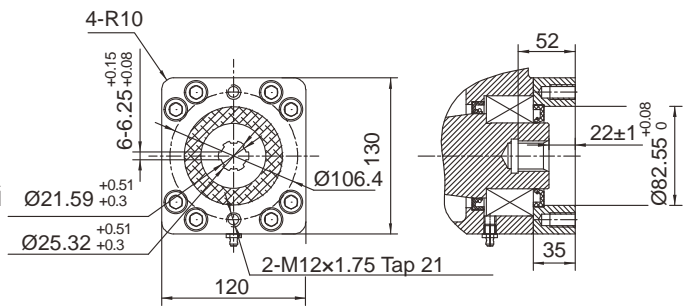
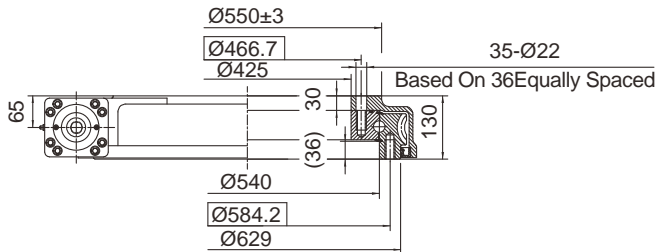

**6B SPLINE**

## MOMENT LOAD CHART

## MOUNTING HOLES OPTION

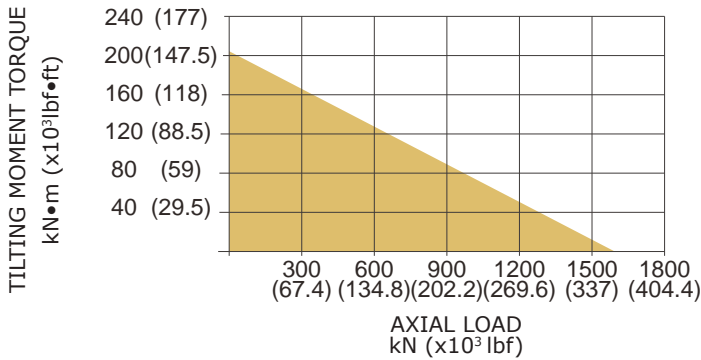

CODE 6&7	M (OUTER RING)	N (INNER RING)
- -	M20×2.5 Tap 40	M20×2.5 Tap 40
- T	M20×2.5 Tap 40	Ø22 Thru
B -	3/4"-10UNC-2B Tap 40	3/4"-10UNC-2B Tap 40
B T	3/4"-10UNC-2B Tap 40	Ø22 Thru

## PERFORMANCE PARAMETERS

OUTPUT TORQUE	TILTING MOMENT TORQUE	HOLDING TORQUE	STATIC AXIAL RATING	STATIC RADIAL RATING	DYNAMIC AXIAL RATING	DYNAMIC RADIAL RATING	GEAR RATIO	TRACKING PRECISION	WEIGHT
48 kN.m	203 kN.m	179.9 kN.m	1598 kN	640 kN	385 kN	335 kN	90 : 1	≤ 0.13°	205 kg
35400 lbf.ft	150×10 <sup>3</sup> lbf.ft	133×10 <sup>3</sup> lbf.ft	359×10 <sup>3</sup> lbf	144×10 <sup>3</sup> lbf	87×10 <sup>3</sup> lbf	75×10 <sup>3</sup> lbf			452 lb

# Series WEA25 Dimensions and Ratings

All dimensions in mm unless otherwise specified

## FRONT

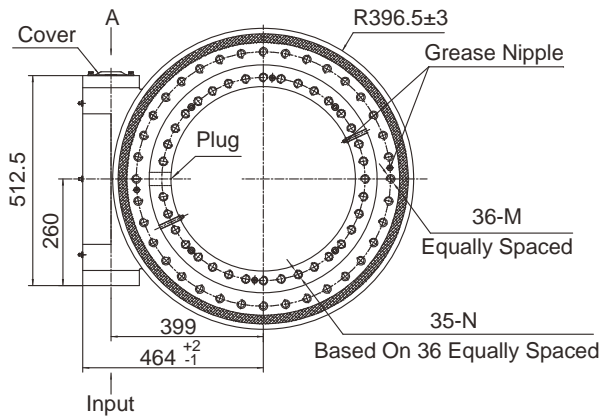

## INPUT

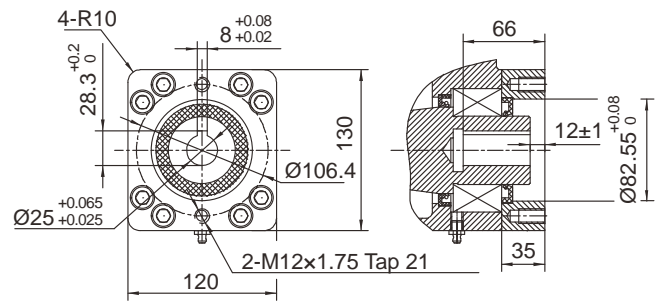

Ø25

## SIDE

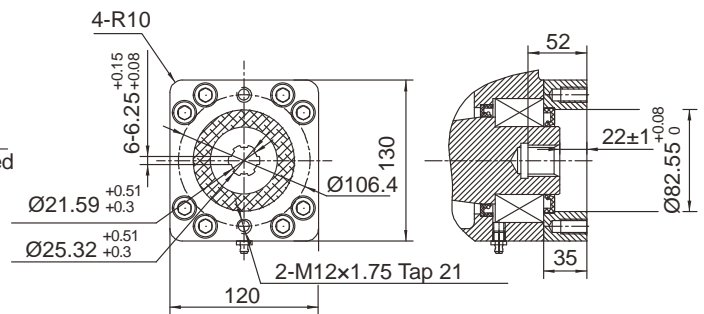
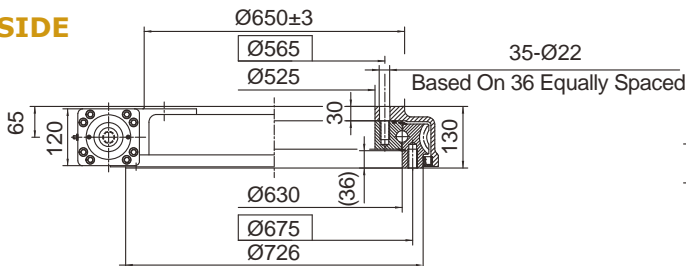

6B SPLINE

## MOMENT LOAD CHART

## MOUNTING HOLES OPTION

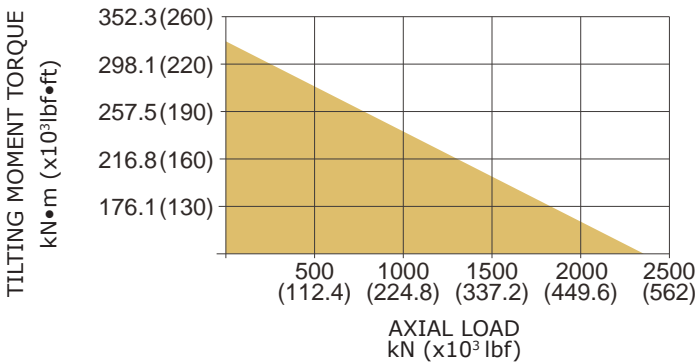

CODE 6&7	M (OUTER RING)	N (INNER RING)
- -	M20×2.5 Tap 40	M20×2.5 Tap 40
- T	M20×2.5 Tap 40	Ø22 Thru
B -	3/4"-10UNC-2B Tap 40	3/4"-10UNC-2B Tap 40
B T	3/4"-10UNC-2B Tap 40	Ø22 Thru

## PERFORMANCE PARAMETERS

OUTPUT TORQUE	TILTING MOMENT TORQUE	HOLDING TORQUE	STATIC AXIAL RATING	STATIC RADIAL RATING	DYNAMIC AXIAL RATING	DYNAMIC RADIAL RATING	GEAR RATIO	TRACKING PRECISION	WEIGHT
34.2 kN.m	310 kN.m	158.3 kN.m	2360 kN	945 kN	590 kN	470 kN	104 : 1	≤ 0.1°	202 kg
25240 lbf.ft	229×10 <sup>3</sup> lbf.ft	117×10 <sup>3</sup> lbf.ft	531×10 <sup>3</sup> lbf	212×10 <sup>3</sup> lbf	133×10 <sup>3</sup> lbf	106×10 <sup>3</sup> lbf			445 lb

All dimensions in mm unless otherwise specified

## FRONT

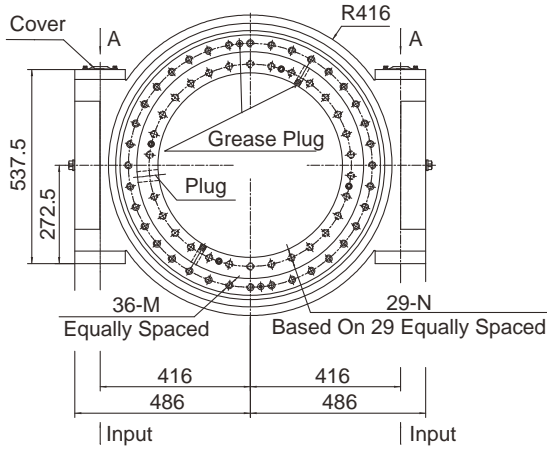

## INPUT

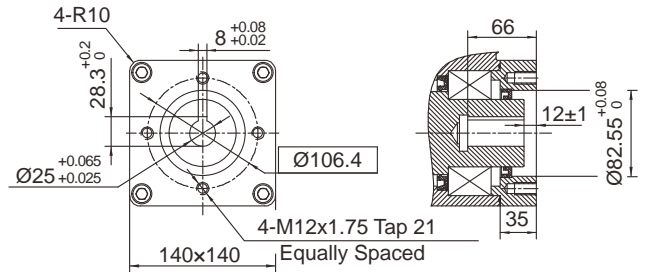

## SIDE

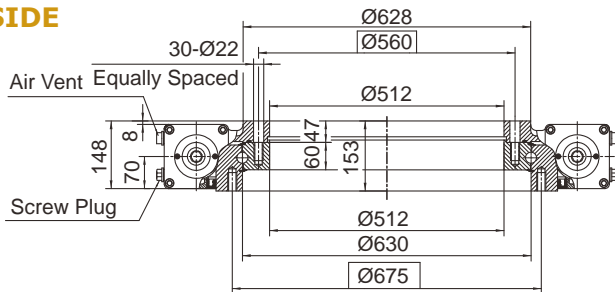

## Ø25

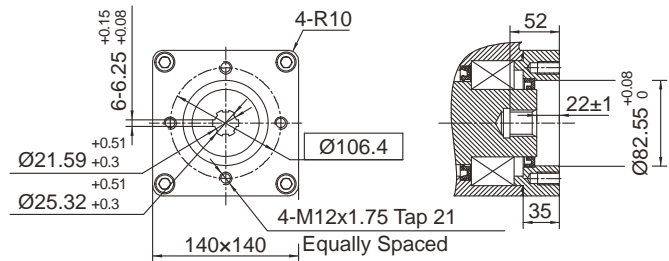

## 6B SPLINE

## MOMENT LOAD CHART

## MOUNTING HOLES OPTION

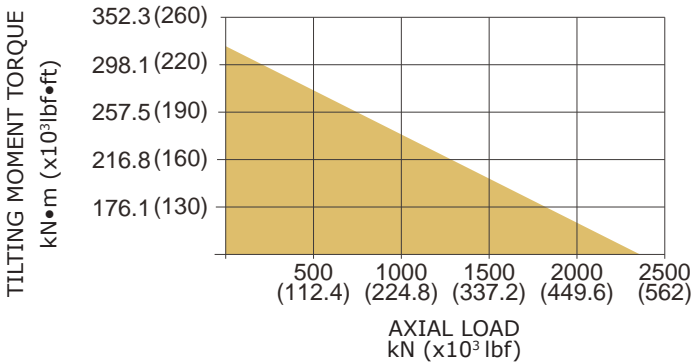

CODE	M (OUTER RING)	N (INNER RING)
6&7	M20×2.5 Tap 40	M20×2.5 Tap 40
- T	M20×2.5 Tap 40	Ø22 Thru
B -	3/4"-10UNC-2B Tap 40	3/4"-10UNC-2B Tap 40
B T	3/4"-10UNC-2B Tap 40	Ø22 Thru

## PERFORMANCE PARAMETERS

OUTPUT TORQUE	TILTING MOMENT TORQUE	HOLDING TORQUE	STATIC AXIAL RATING	STATIC RADIAL RATING	DYNAMIC AXIAL RATING	DYNAMIC RADIAL RATING	GEAR RATIO	TRACKING PRECISION	WEIGHT
58 kN.m	310 kN.m	247 kN.m	2360 kN	945 kN	590 kN	470 kN	108 : 1	≤ 0.1 °	273 kg
42800 lbf.ft	229×10³ lbf.ft	182.3×10³ lbf.ft	531×10³ lbf	212×10³ lbf	133×10³ lbf	106×10³ lbf			602 lb

# Series WEA28 Dimensions and Ratings

All dimensions in mm unless otherwise specified

## FRONT

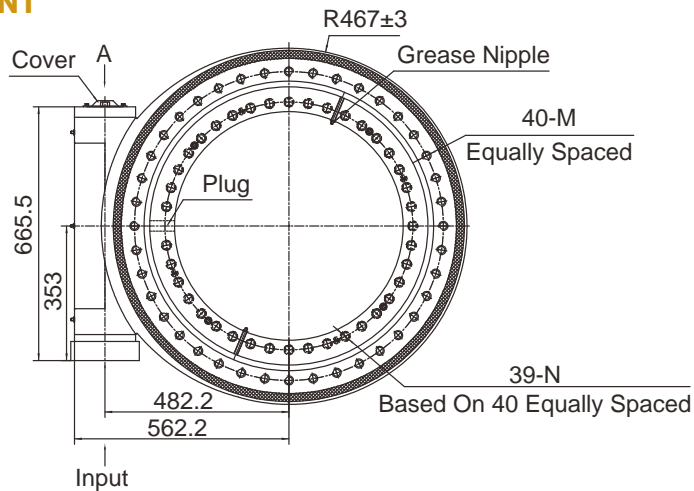

## INPUT

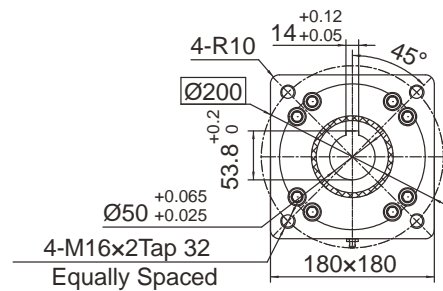

## SIDE

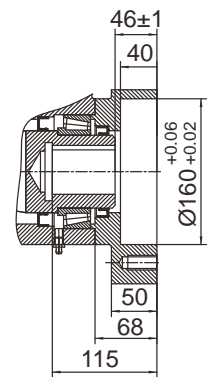
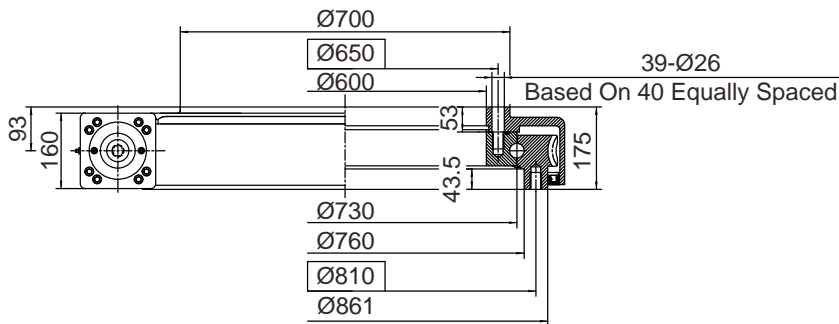

Ø50

## MOMENT LOAD CHART

## MOUNTING HOLES OPTION

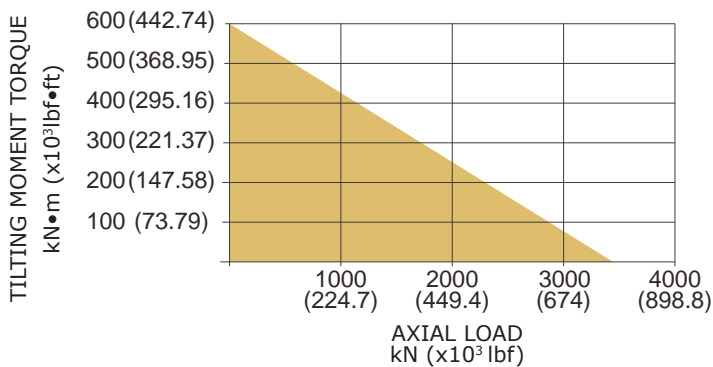

CODE 6&7	M (OUTER RING)	N (INNER RING)
--	M24×3 Tap 36	M24×3 Tap 36
- T	M24×3 Tap 36	Ø26 Thru
B -	7/8"-9UNC-2B Tap 36	7/8"-9UNC-2B Tap 36
B T	7/8"-9UNC-2B Tap 36	Ø26 Thru

## PERFORMANCE PARAMETERS

OUTPUT TORQUE	TILTING MOMENT TORQUE	HOLDING TORQUE	STATIC AXIAL RATING	STATIC RADIAL RATING	DYNAMIC AXIAL RATING	DYNAMIC RADIAL RATING	GEAR RATIO	TRACKING PRECISION	WEIGHT
40 kN.m	600 kN.m	250 kN.m	3400 kN	1360 kN	850 kN	680 kN	110 : 1	≤ 0.15°	418 kg
29516 lbf.ft	443×10³ lbf.ft	184×10³ lbf.ft	764×10³ lbf	306×10³ lbf	191×10³ lbf	152.8×10³ lbf			921 lb

All dimensions in mm unless otherwise specified

## FRONT

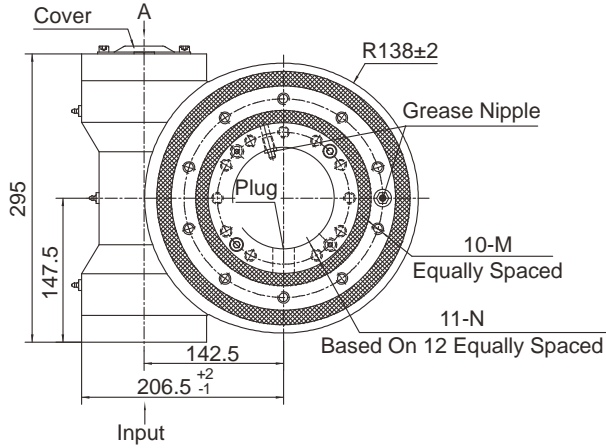

## SIDE

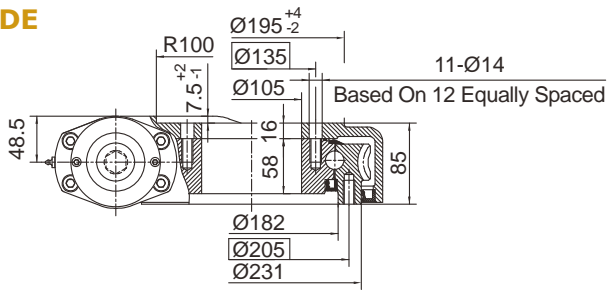

## INPUT

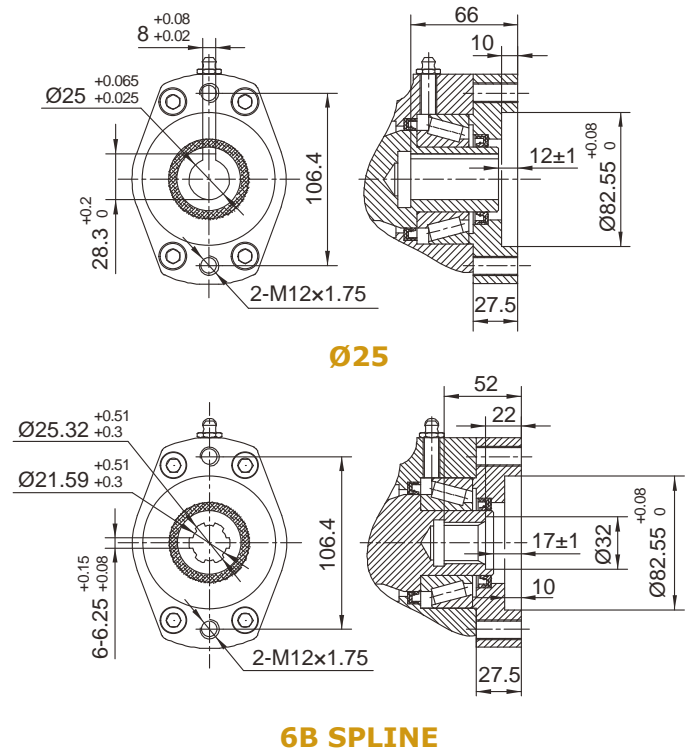

## MOMENT LOAD CHART

## MOUNTING HOLES OPTION

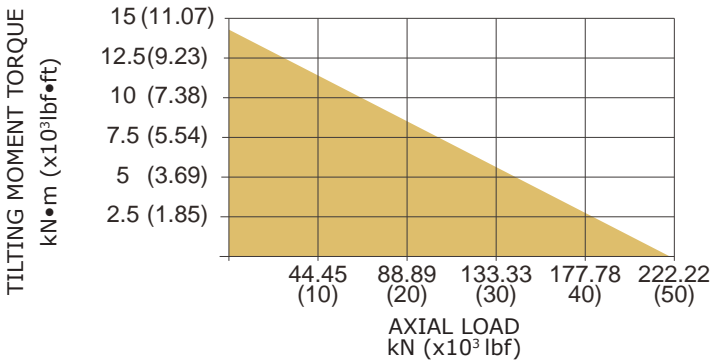

CODE 6&7	M (OUTER RING)	N (INNER RING)
- -	M12×1.75 Tap 25	M12×1.75 Tap 25
- T	M12×1.75 Tap 25	Ø14 Thru
B -	1/2"-13UNC-2B Tap 25	1/2"-13UNC-2B Tap 25
B T	1/2"-13UNC-2B Tap 25	Ø14 Thru

## PERFORMANCE PARAMETERS

OUTPUT TORQUE	TILTING MOMENT TORQUE	HOLDING TORQUE	STATIC AXIAL RATING	STATIC RADIAL RATING	DYNAMIC AXIAL RATING	DYNAMIC RADIAL RATING	GEAR RATIO	TRACKING PRECISION	WEIGHT
3.5 kN.m	14.2 kN.m	20 kN.m	220 kN	90 kN	63 kN	48 kN	47 : 1	≤ 0.15°	37 kg
2583 lbf.ft	10.5×10 <sup>3</sup> lbf.ft	14.8×10 <sup>3</sup> lbf.ft	49.5×10 <sup>3</sup> lbf	20.2×10 <sup>3</sup> lbf	14.2×10 <sup>3</sup> lbf	10.8×10 <sup>3</sup> lbf			82 lb



All dimensions in mm unless otherwise specified

## FRONT

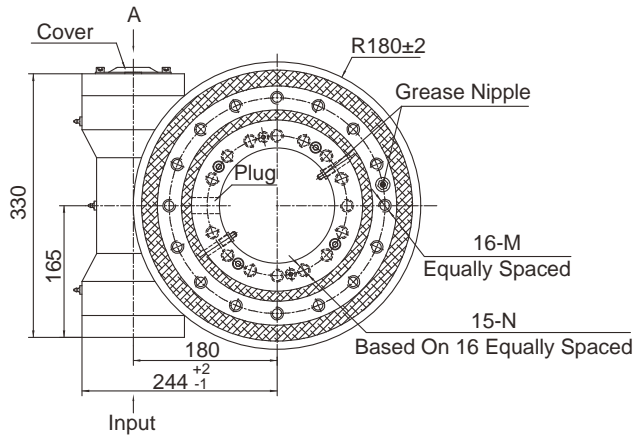

## INPUT

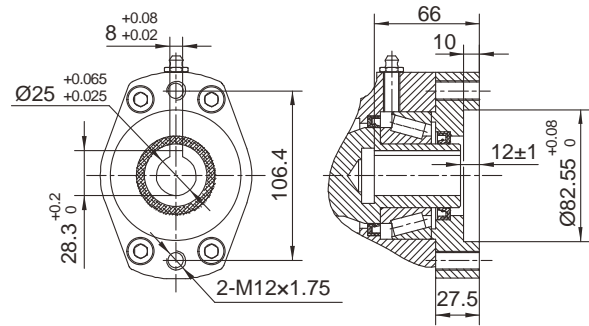

Ø25

## SIDE

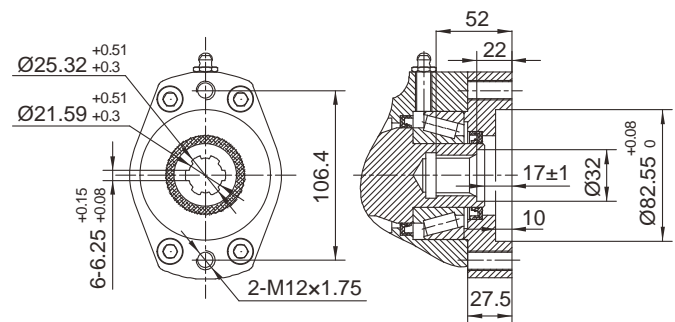
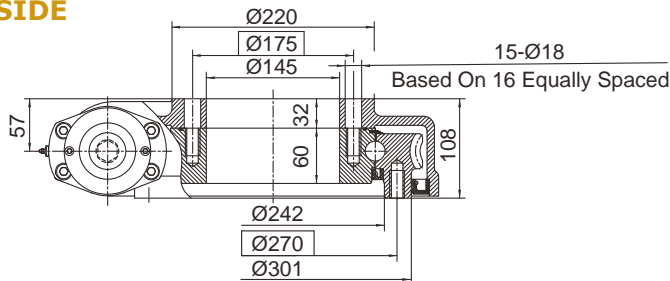

6B SPLINE

## MOMENT LOAD CHART

## MOUNTING HOLES OPTION

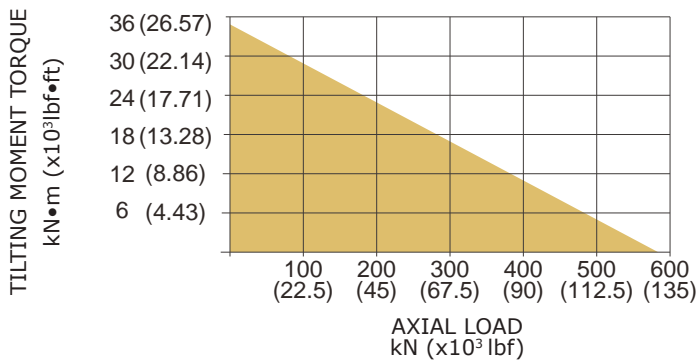

CODE	M (OUTER RING)	N (INNER RING)
6&7	M16×2 Tap 30	M16×2 Tap 30
- T	M16×2 Tap 30	Ø18 Thru
B -	5/8"-11UNC-2B Tap 30	5/8"-11UNC-2B Tap 30
B T	5/8"-11UNC-2B Tap 30	Ø18 Thru

## PERFORMANCE PARAMETERS

OUTPUT TORQUE	TILTING MOMENT TORQUE	HOLDING TORQUE	STATIC AXIAL RATING	STATIC RADIAL RATING	DYNAMIC AXIAL RATING	DYNAMIC RADIAL RATING	GEAR RATIO	TRACKING PRECISION	WEIGHT
8 kN.m	35.6 kN.m	34.5 kN.m	578 kN	215 kN	136 kN	115 kN	62 : 1	≤ 0.15°	54 kg
5904 lbf.ft	26.3×10 <sup>3</sup> lbf.ft	25.5×10 <sup>3</sup> lbf.ft	129.9×10 <sup>3</sup> lbf	48.3×10 <sup>3</sup> lbf	30.6×10 <sup>3</sup> lbf	25.9×10 <sup>3</sup> lbf			119 lb

All dimensions in mm unless otherwise specified

## FRONT

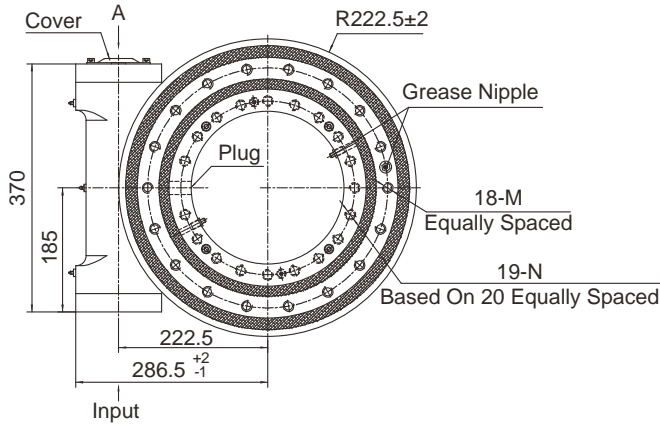

## INPUT

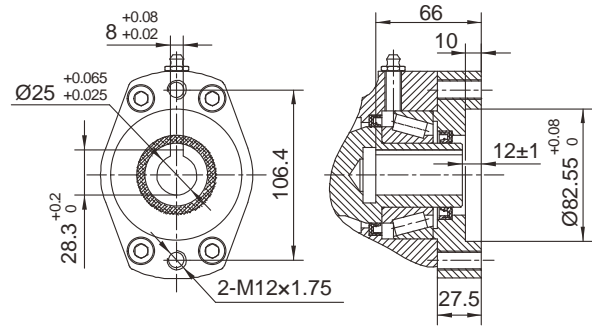

## SIDE

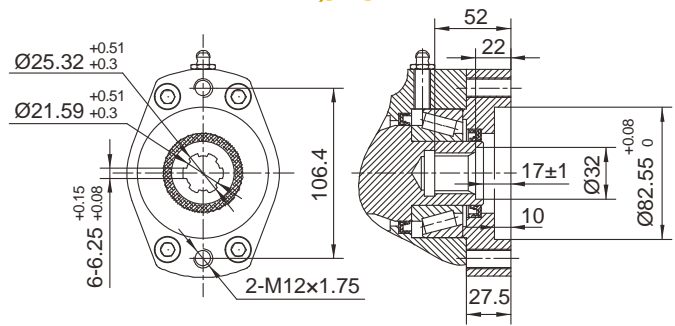
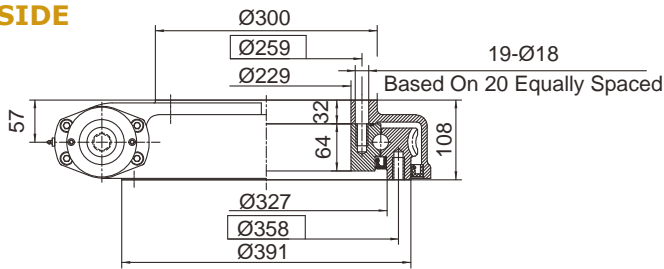

## 6B SPLINE

## MOMENT LOAD CHART

## MOUNTING HOLES OPTION

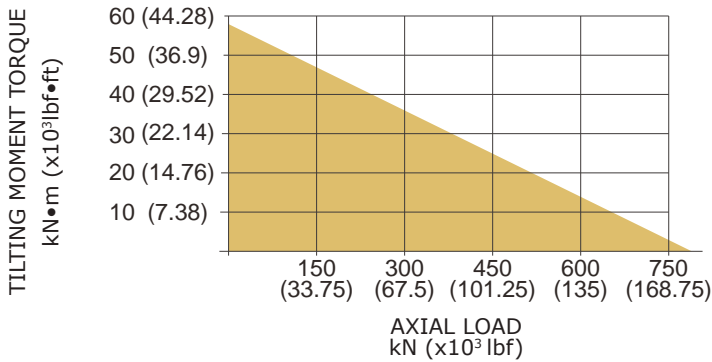

CODE 6&7	M (OUTER RING)	N (INNER RING)
--	M16×2 Tap 30	M16×2 Tap 30
- T	M16×2 Tap 30	Ø18 Thru
B -	5/8"-11UNC-2B Tap 30	5/8"-11UNC-2B Tap 30
B T	5/8"-11UNC-2B Tap 30	Ø18 Thru

## PERFORMANCE PARAMETERS

OUTPUT TORQUE	TILTING MOMENT TORQUE	HOLDING TORQUE	STATIC AXIAL RATING	STATIC RADIAL RATING	DYNAMIC AXIAL RATING	DYNAMIC RADIAL RATING	GEAR RATIO	TRACKING PRECISION	WEIGHT
9.5 kN.m	57 kN.m	43 kN.m	760 kN	280 kN	190 kN	148 kN	79 : 1	≤ 0.15°	70 kg
7011 lbf.ft	42.1×10 <sup>3</sup> lbf.ft	32×10 <sup>3</sup> lbf.ft	171.1×10 <sup>3</sup> lbf	62.9×10 <sup>3</sup> lbf	42.7×10 <sup>3</sup> lbf	33.3×10 <sup>3</sup> lbf			154 lb

All dimensions in mm unless otherwise specified

## FRONT

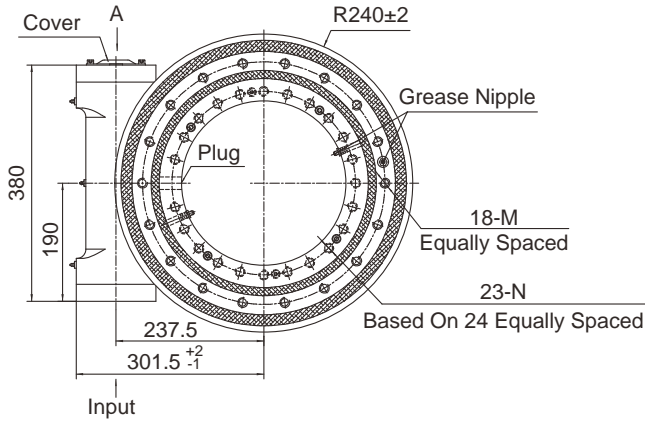

## INPUT

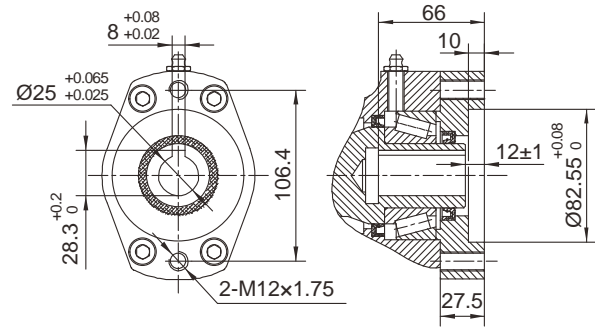

Ø25

## SIDE

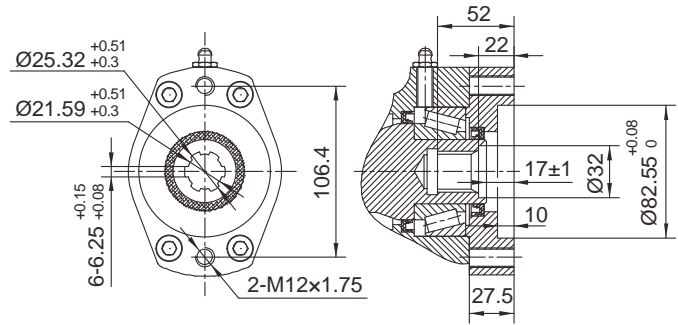
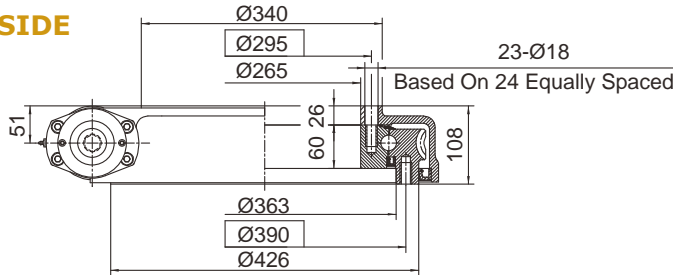

6B SPLINE

## MOMENT LOAD CHART

## MOUNTING HOLES OPTION

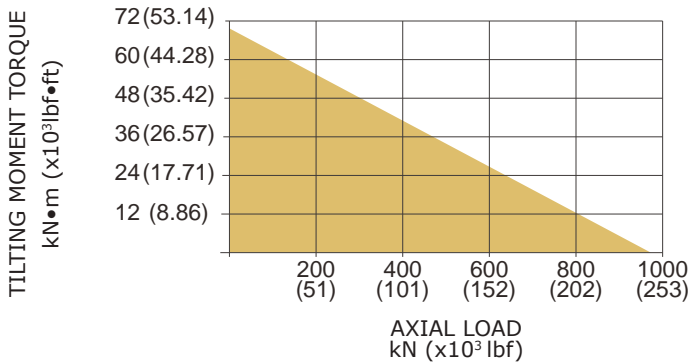

CODE	M (OUTER RING)	N (INNER RING)
6&7		
--	M16×2 Tap 30	M16×2 Tap 30
-T	M16×2 Tap 30	Ø18 Thru
B-	5/8"-11UNC-2B Tap 30	5/8"-11UNC-2B Tap 30
BT	5/8"-11UNC-2B Tap 30	Ø18 Thru

## PERFORMANCE PARAMETERS

OUTPUT TORQUE	TILTING MOMENT TORQUE	HOLDING TORQUE	STATIC AXIAL RATING	STATIC RADIAL RATING	DYNAMIC AXIAL RATING	DYNAMIC RADIAL RATING	GEAR RATIO	TRACKING PRECISION	WEIGHT
10.8 kN.m	71.2 kN.m	48 kN.m	960 kN	360 kN	230 kN	200 kN	86 : 1	≤ 0.13°	76 kg
7970 lbf.ft	52.6×10 <sup>3</sup> lbf.ft	35×10 <sup>3</sup> lbf.ft	215.8×10 <sup>3</sup> lbf	80.9×10 <sup>3</sup> lbf	51.7×10 <sup>3</sup> lbf	44.9×10 <sup>3</sup> lbf			168 lb

All dimensions in mm unless otherwise specified

## FRONT

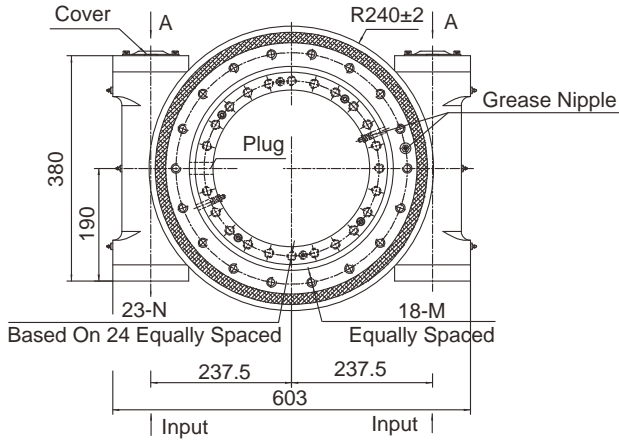

## INPUT

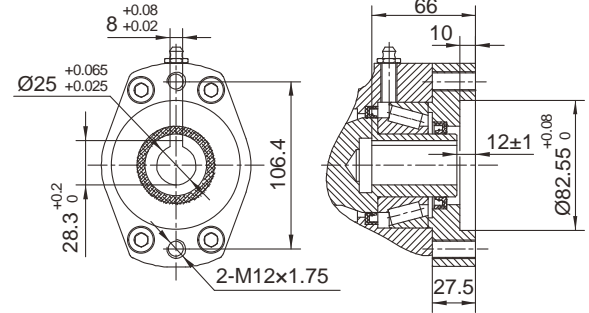

## SIDE

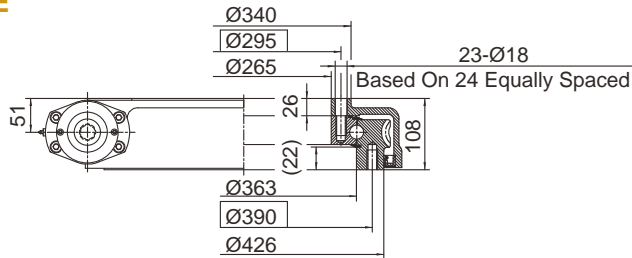

## Ø25

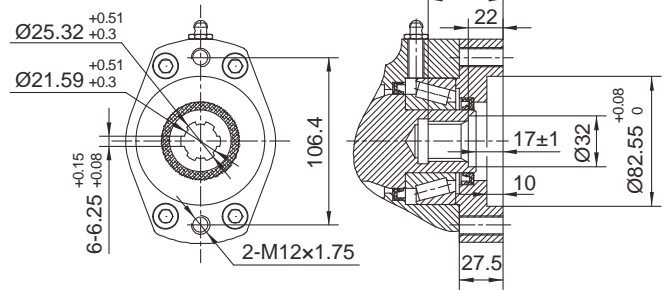

## 6B SPLINE

## MOMENT LOAD CHART

## MOUNTING HOLES OPTION

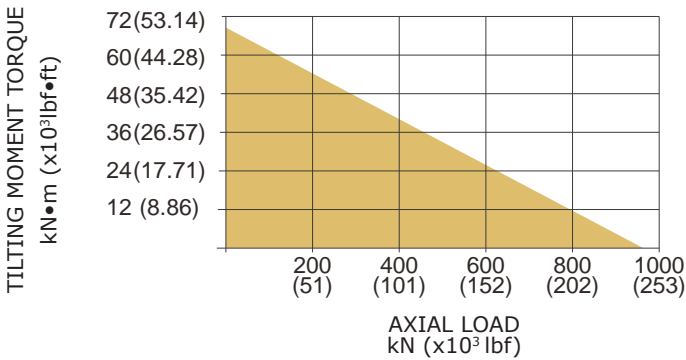

CODE 6&7	M (OUTER RING)	N (INNER RING)
- -	M16×2 Tap 30	M16×2 Tap 30
- T	M16×2 Tap 30	Ø18 Thru
B -	5/8"-11UNC-2B Tap 30	5/8"-11UNC-2B Tap 30
B T	5/8"-11UNC-2B Tap 30	Ø18 Thru

## PERFORMANCE PARAMETERS

OUTPUT TORQUE	TILTING MOMENT TORQUE	HOLDING TORQUE	STATIC AXIAL RATING	STATIC RADIAL RATING	DYNAMIC AXIAL RATING	DYNAMIC RADIAL RATING	GEAR RATIO	TRACKING PRECISION	WEIGHT
16.2 kN.m	71.2 kN.m	82 kN.m	960 kN	360 kN	230 kN	200 kN	86 : 1	≤ 0.15°	92 kg
11956 lbf.ft	52.6×10 <sup>3</sup> lbf.ft	60.5×10 <sup>3</sup> lbf.ft	215.8×10 <sup>3</sup> lbf	80.9×10 <sup>3</sup> lbf	51.7×10 <sup>3</sup> lbf	44.9×10 <sup>3</sup> lbf			203 lb

# Series WEB15 Dimensions and Ratings

All dimensions in mm unless otherwise specified

## FRONT

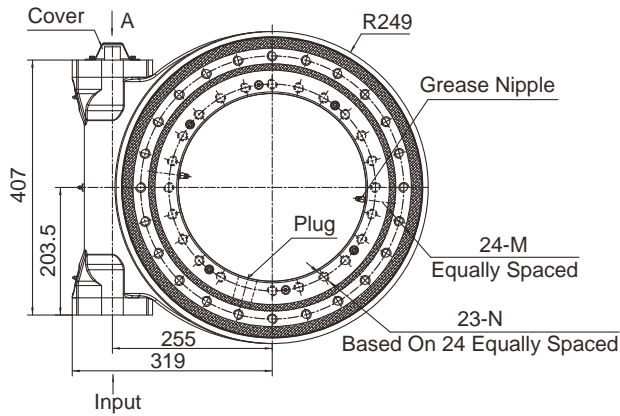

## INPUT

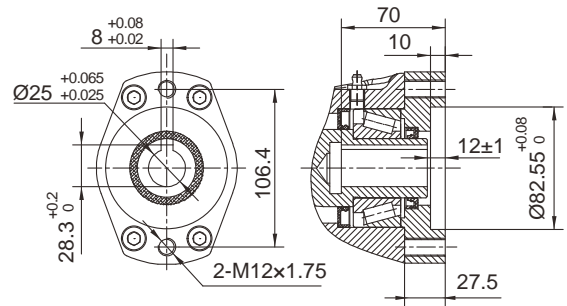

## SIDE

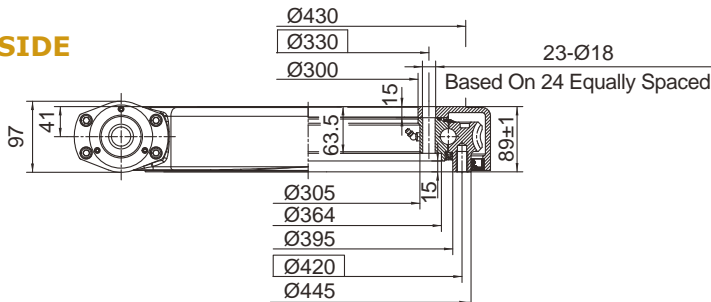

## Ø25

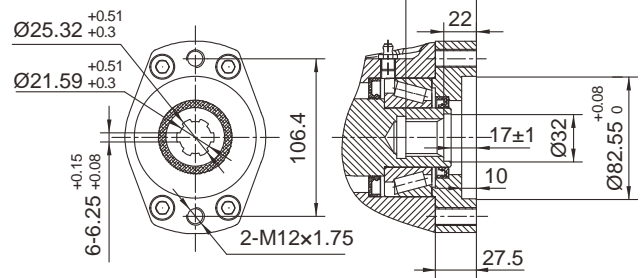

## 6B SPLINE

## MOMENT LOAD CHART

## MOUNTING HOLES OPTION

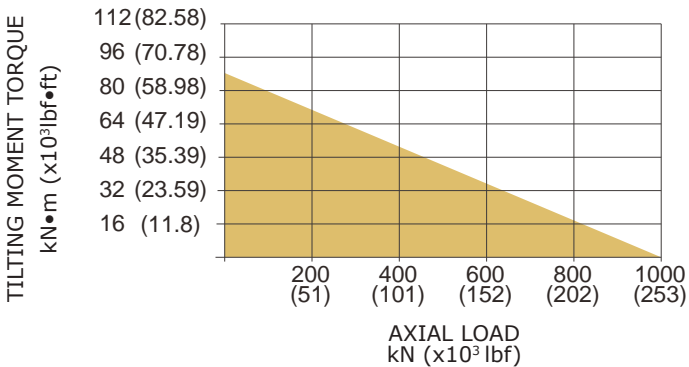

CODE	M (OUTER RING)	N (INNER RING)
6&7	M16×2 Tap 28	M16×2 Tap 28
- T	M16×2 Tap 28	Ø17 Thru
B -	5/8"-11UNC-2B Tap 28	5/8"-11UNC-2B Tap 28
B T	5/8"-11UNC-2B Tap 28	Ø17 Thru

## PERFORMANCE PARAMETERS

OUTPUT TORQUE	TILTING MOMENT TORQUE	HOLDING TORQUE	STATIC AXIAL RATING	STATIC RADIAL RATING	DYNAMIC AXIAL RATING	DYNAMIC RADIAL RATING	GEAR RATIO	TRACKING PRECISION	WEIGHT
12 kN.m	90 kN.m	50 kN.m	1000 kN	400 kN	240 kN	220 kN	92 : 1	≤ 0.1°	68 kg
8856 lbf.ft	66×10 <sup>3</sup> lbf.ft	37×10 <sup>3</sup> lbf.ft	224.8×10 <sup>3</sup> lbf	89.9×10 <sup>3</sup> lbf	54×10 <sup>3</sup> lbf	49.5×10 <sup>3</sup> lbf			150 lb

All dimensions in mm unless otherwise specified

## FRONT

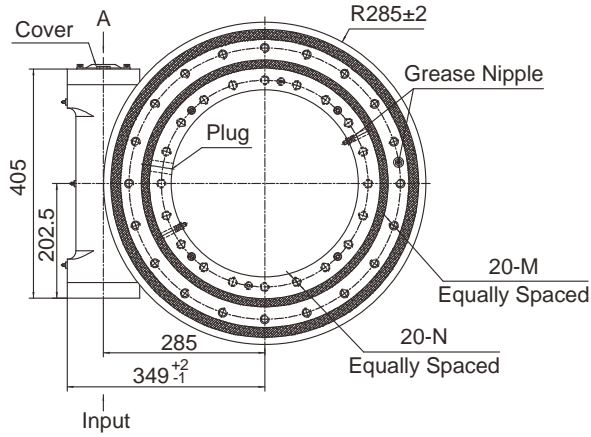

## INPUT

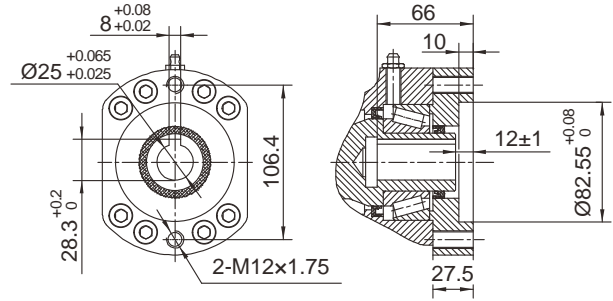

## SIDE

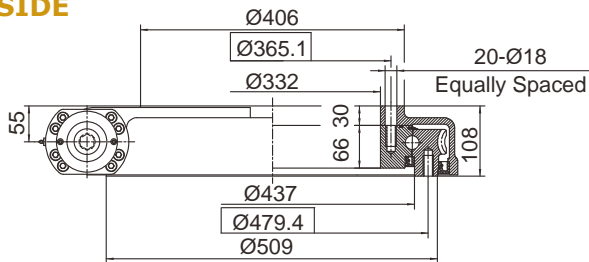

## Ø25

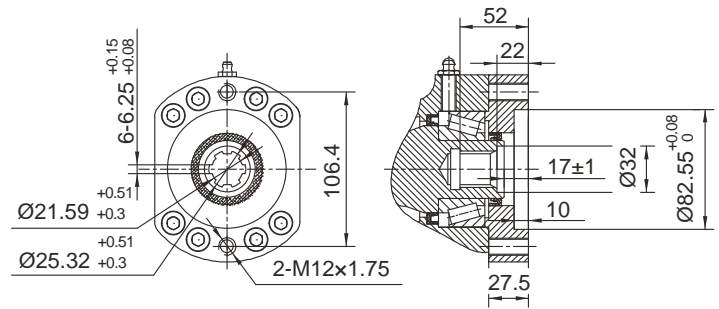

## 6B SPLINE

## MOMENT LOAD CHART

## MOUNTING HOLES OPTION

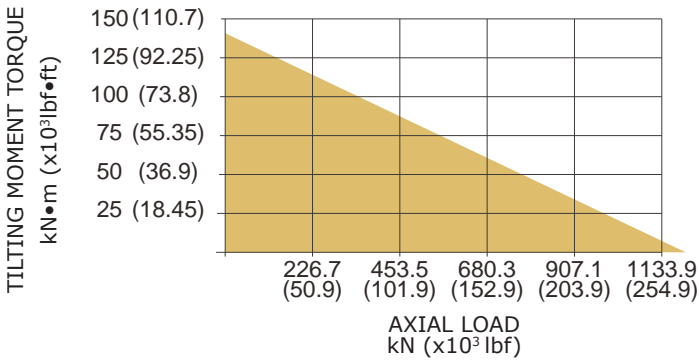

CODE 6&7	M (OUTER RING)	N (INNER RING)
- -	M16x2 Tap 32	M16x2 Tap 32
- T	M16x2 Tap 32	Ø18 Thru
B -	5/8"-11UNC-2B Tap 32	5/8"-11UNC-2B Tap 32
B T	5/8"-11UNC-2B Tap 32	Ø18 Thru

## PERFORMANCE PARAMETERS

OUTPUT TORQUE	TILTING MOMENT TORQUE	HOLDING TORQUE	STATIC AXIAL RATING	STATIC RADIAL RATING	DYNAMIC AXIAL RATING	DYNAMIC RADIAL RATING	GEAR RATIO	TRACKING PRECISION	WEIGHT
12.96 kN.m	142.4 kN.m	72.3 kN.m	1166 kN	435 kN	280 kN	231 kN	104 : 1	≤ 0.1°	101 kg
9564 lbf.ft	105x10 <sup>3</sup> lbf.ft	53.4x10 <sup>3</sup> lbf.ft	262x10 <sup>3</sup> lbf	97.8x10 <sup>3</sup> lbf	62.9x10 <sup>3</sup> lbf	51.9x10 <sup>3</sup> lbf			223 lb

# Series WEB17-2 Dimensions and Ratings

All dimensions in mm unless otherwise specified

## FRONT

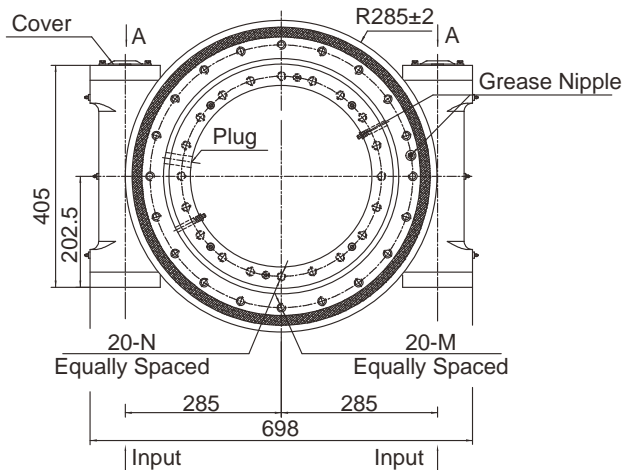

## SIDE

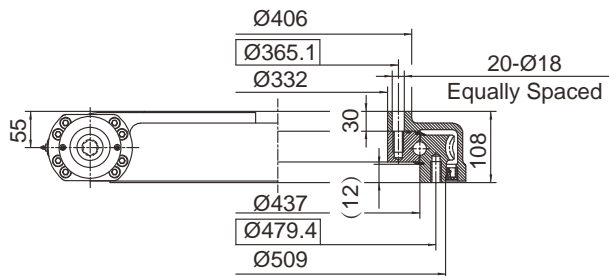

## INPUT

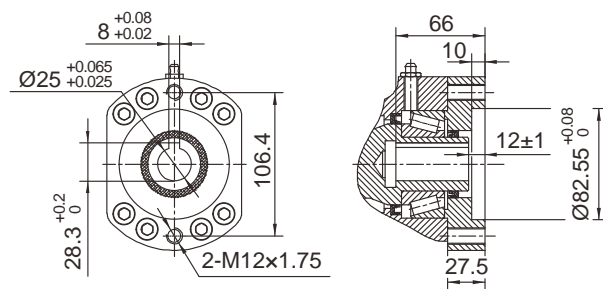

Ø25

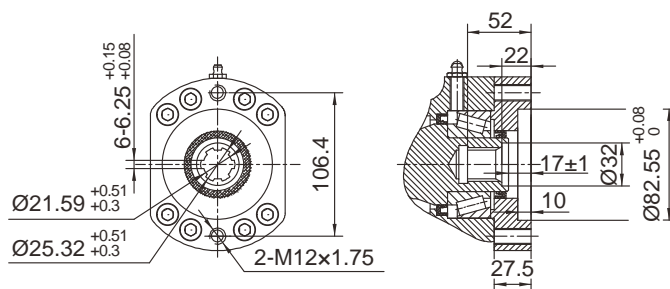

6B SPLINE

## MOMENT LOAD CHART

## MOUNTING HOLES OPTION

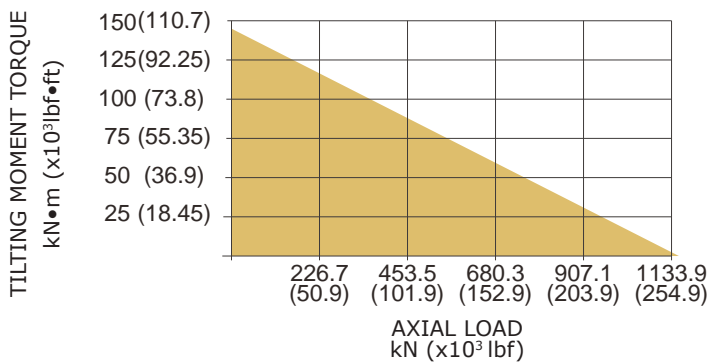

CODE 6&7	M (OUTER RING)	N (INNER RING)
- -	M16×2 Tap 32	M16×2 Tap 32
- T	M16×2 Tap 32	Ø18 Thru
B -	5/8"-11UNC-2B Tap 32	5/8"-11UNC-2B Tap 32
B T	5/8"-11UNC-2B Tap 32	Ø18 Thru

## PERFORMANCE PARAMETERS

OUTPUT TORQUE	TILTING MOMENT TORQUE	HOLDING TORQUE	STATIC AXIAL RATING	STATIC RADIAL RATING	DYNAMIC AXIAL RATING	DYNAMIC RADIAL RATING	GEAR RATIO	TRACKING PRECISION	WEIGHT
19.44 kN.m	142.4 kN.m	94 kN.m	1166 kN	435 kN	280 kN	231 kN	104 : 1	≤ 0.15°	121 kg
14347 lbf.ft	105.1×10 <sup>3</sup> lbf.ft	69.3×10 <sup>3</sup> lbf.ft	262×10 <sup>3</sup> lbf	97.8×10 <sup>3</sup> lbf	62.9×10 <sup>3</sup> lbf	51.9×10 <sup>3</sup> lbf			267 lb



All dimensions in mm unless otherwise specified

## FRONT

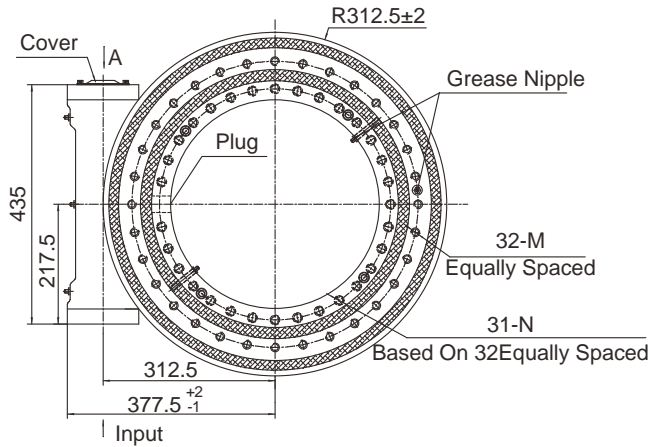

## INPUT

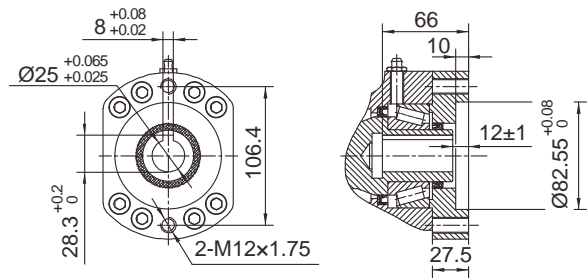

## Ø25

## SIDE

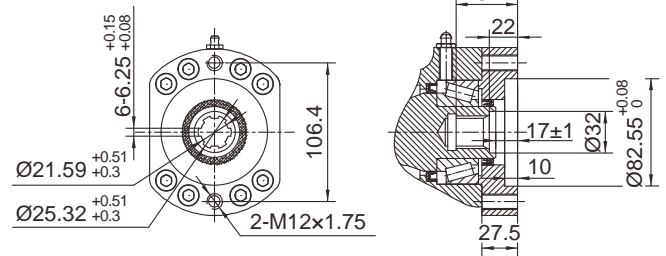
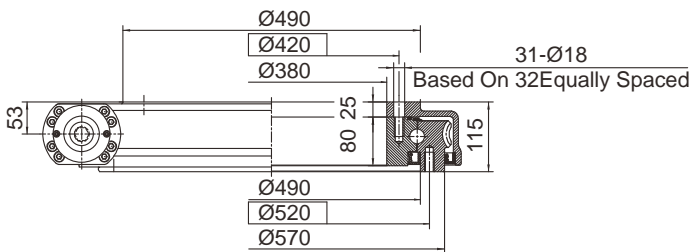

## 6B SPLINE

## MOMENT LOAD CHART

## MOUNTING HOLES OPTION

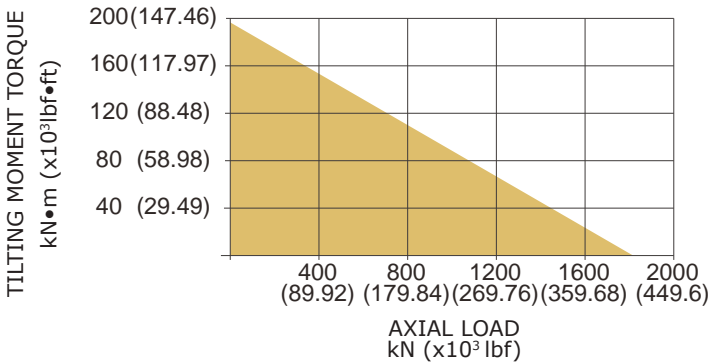

CODE 6&7	M (OUTER RING)	N (INNER RING)
- -	M16×2 Tap 32	M16×2 Tap 32
- T	M16×2 Tap 32	Ø18 Thru
B -	5/8"-11UNC-2B Tap 32	5/8"-11UNC-2B Tap 32
B T	5/8"-11UNC-2B Tap 32	Ø18 Thru

## PERFORMANCE PARAMETERS

OUTPUT TORQUE	TILTING MOMENT TORQUE	HOLDING TORQUE	STATIC AXIAL RATING	STATIC RADIAL RATING	DYNAMIC AXIAL RATING	DYNAMIC RADIAL RATING	GEAR RATIO	TRACKING PRECISION	WEIGHT
18.5 kN.m	196 kN.m	80.1 kN.m	1800 kN	675 kN	290 kN	250 kN	94 : 1	≤ 0.1°	128 kg
13653 lbf.ft	144.6×10³ lbf.ft	59.1×10³ lbf.ft	404.6×10³ lbf	151.7×10³ lbf	65.2×10³ lbf	56.2×10³ lbf			282 lb

# Series WEB21 Dimensions and Ratings

All dimensions in mm unless otherwise specified

## FRONT

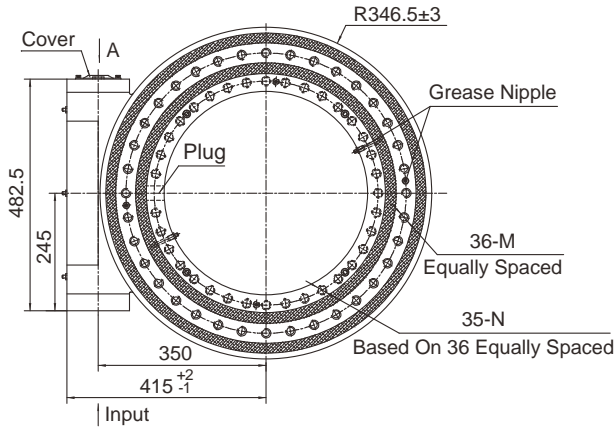

## INPUT

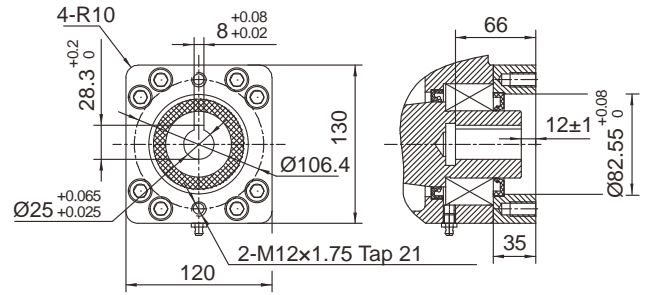

## SIDE

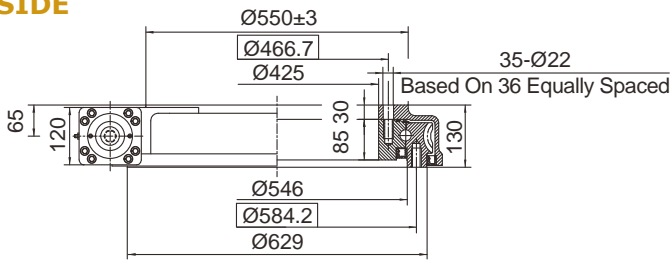

## Ø25

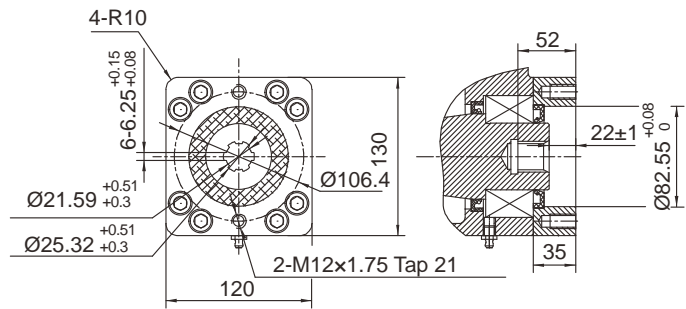

## 6B SPLINE

## MOMENT LOAD CHART

## MOUNTING HOLES OPTION

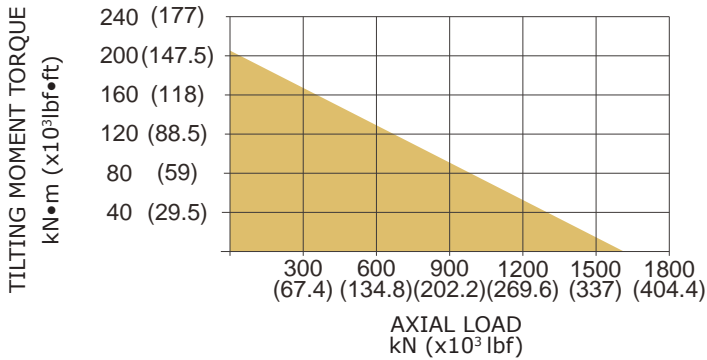

CODE 6&7	M (OUTER RING)	N (INNER RING)
- -	M20×2.5 Tap 40	M20×2.5 Tap 40
- T	M20×2.5 Tap 40	Ø22 Thru
B -	3/4"-10UNC-2B Tap 40	3/4"-10UNC-2B Tap 40
B T	3/4"-10UNC-2B Tap 40	Ø22 Thru

## PERFORMANCE PARAMETERS

OUTPUT TORQUE	TILTING MOMENT TORQUE	HOLDING TORQUE	STATIC AXIAL RATING	STATIC RADIAL RATING	DYNAMIC AXIAL RATING	DYNAMIC RADIAL RATING	GEAR RATIO	TRACKING PRECISION	WEIGHT
28.7 kN.m	203 kN.m	105.8 kN.m	1598 kN	640 kN	385 kN	335 kN	90 : 1	≤ 0.1°	182 kg
21180 lbf.ft	150×10 <sup>3</sup> lbf.ft	78.1×10 <sup>3</sup> lbf.ft	359×10 <sup>3</sup> lbf	144×10 <sup>3</sup> lbf	87×10 <sup>3</sup> lbf	75×10 <sup>3</sup> lbf			401 lb

All dimensions in mm unless otherwise specified

## FRONT

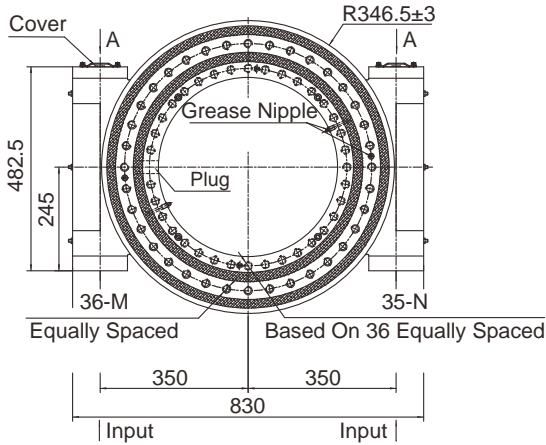

## SIDE

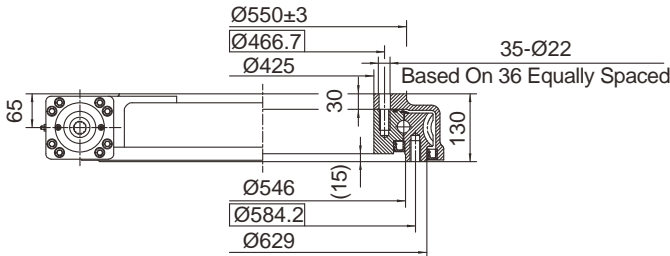

## INPUT

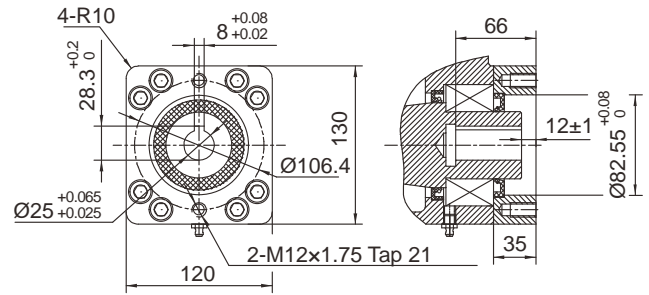

## Ø25

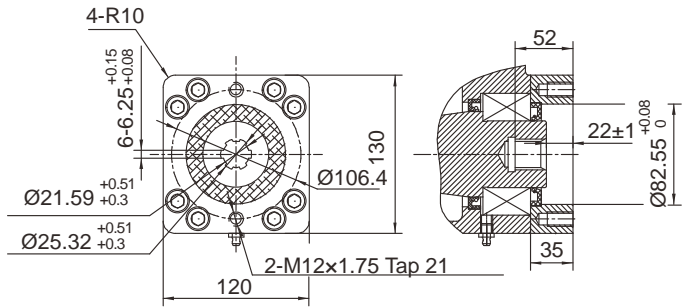

## 6B SPLINE

## MOMENT LOAD CHART

## MOUNTING HOLES OPTION

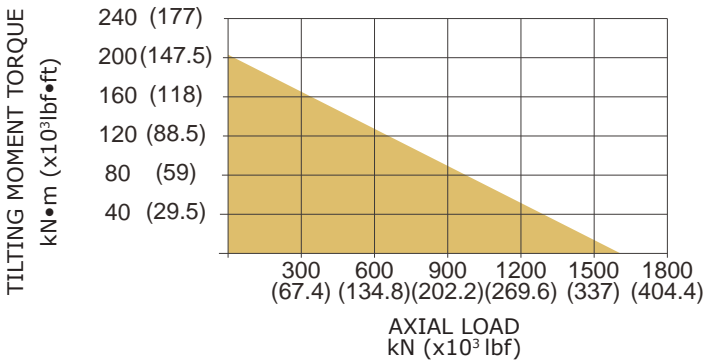

CODE 6&7	M (OUTER RING)	N (INNER RING)
--	M20×2.5 Tap 40	M20×2.5 Tap 40
- T	M20×2.5 Tap 40	Ø22 Thru
B -	3/4"-10UNC-2B Tap 40	3/4"-10UNC-2B Tap 40
B T	3/4"-10UNC-2B Tap 40	Ø22 Thru

## PERFORMANCE PARAMETERS

OUTPUT TORQUE	TILTING MOMENT TORQUE	HOLDING TORQUE	STATIC AXIAL RATING	STATIC RADIAL RATING	DYNAMIC AXIAL RATING	DYNAMIC RADIAL RATING	GEAR RATIO	TRACKING PRECISION	WEIGHT
48 kN.m	203 kN.m	179.9 kN.m	1598 kN	640 kN	385 kN	335 kN	90 : 1	≤ 0.13°	213 kg
35400 lbf.ft	150×10 <sup>3</sup> lbf.ft	133×10 <sup>3</sup> lbf.ft	359×10 <sup>3</sup> lbf	144×10 <sup>3</sup> lbf	87×10 <sup>3</sup> lbf	75×10 <sup>3</sup> lbf			470 lb

# Series WEB25 Dimensions and Ratings

All dimensions in mm unless otherwise specified

## FRONT

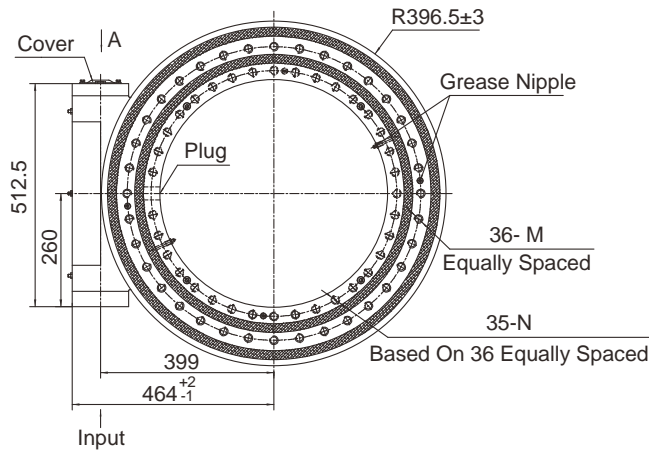

## INPUT

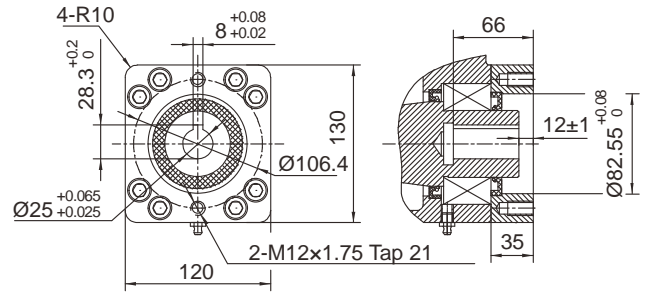

## SIDE

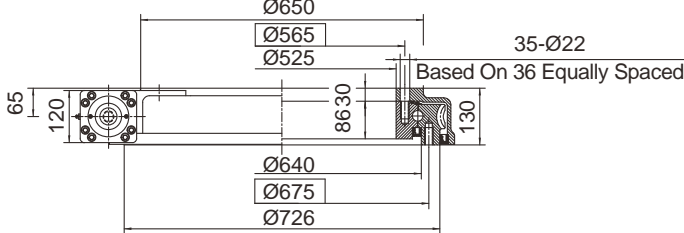

## Ø25

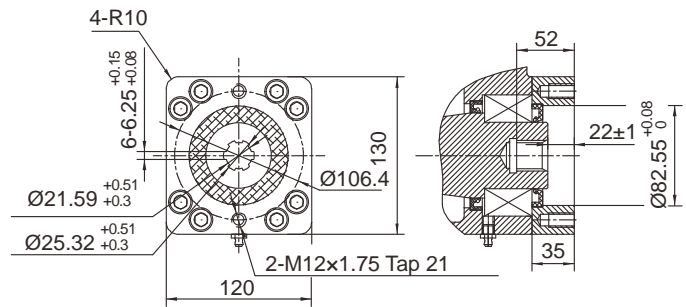

## 6B SPLINE

## MOMENT LOAD CHART

## MOUNTING HOLES OPTION

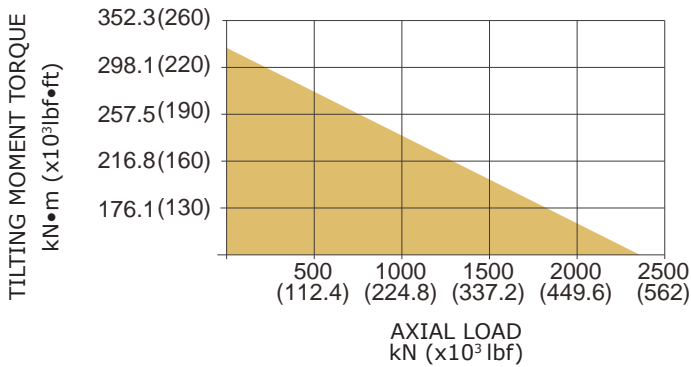

CODE 6&7	M (OUTER RING)	N (INNER RING)
--	M20×2.5 Tap 40	M20×2.5 Tap 40
- T	M20×2.5 Tap 40	Ø22 Thru
B -	3/4"-10UNC-2B Tap 40	3/4"-10UNC-2B Tap 40
B T	3/4"-10UNC-2B Tap 40	Ø22Thru

## PERFORMANCE PARAMETERS

OUTPUT TORQUE	TILTING MOMENT TORQUE	HOLDING TORQUE	STATIC AXIAL RATING	STATIC RADIAL RATING	DYNAMIC AXIAL RATING	DYNAMIC RADIAL RATING	GEAR RATIO	TRACKING PRECISION	WEIGHT
34.2 kN.m	310 kN.m	158.3 kN.m	2360 kN	945 kN	590 kN	470 kN	104 : 1	≤ 0.1°	212 kg
25240 lbf.ft	229×10 <sup>3</sup> lbf.ft	117×10 <sup>3</sup> lbf.ft	531×10 <sup>3</sup> lbf	212×10 <sup>3</sup> lbf	133×10 <sup>3</sup> lbf	106×10 <sup>3</sup> lbf			467 lb

All dimensions in mm unless otherwise specified

## FRONT

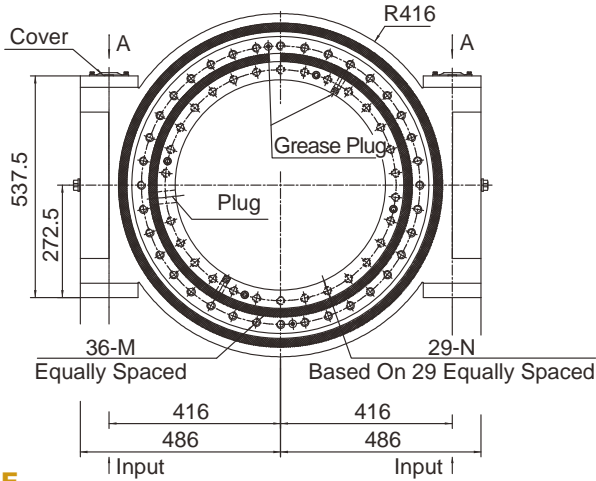

## INPUT

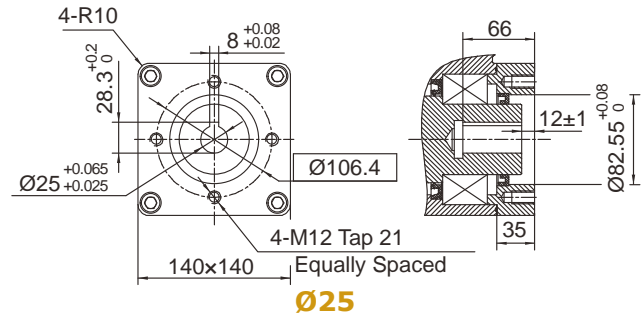

## SIDE

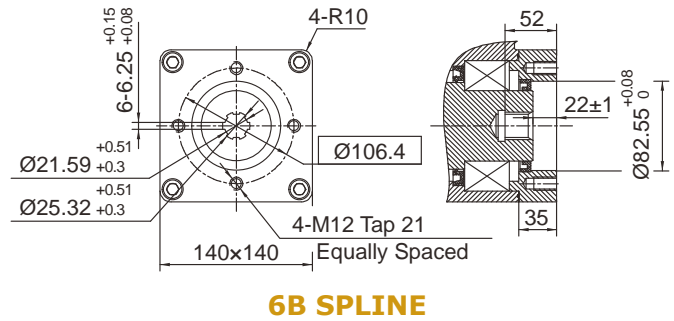
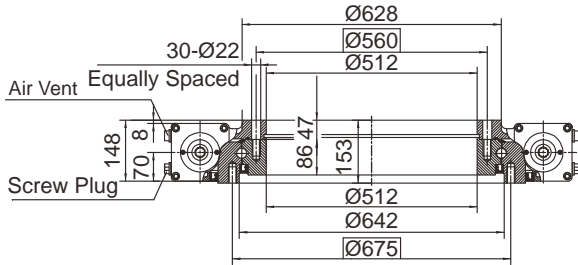

## MOMENT LOAD CHART

## MOUNTING HOLES OPTION

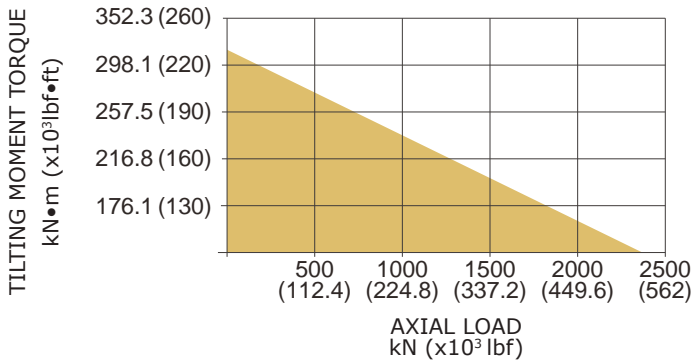

CODE 6&7	M (OUTER RING)	N (INNER RING)
- -	M20×2.5 Tap 40	M20×2.5 Tap 40
- T	M20×2.5 Tap 40	Ø22 Thru
B -	3/4"-10UNC-2B Tap 40	3/4"-10UNC-2B Tap 40
B T	3/4"-10UNC-2B Tap 40	Ø22 Thru

## PERFORMANCE PARAMETERS

OUTPUT TORQUE	TILTING MOMENT TORQUE	HOLDING TORQUE	STATIC AXIAL RATING	STATIC RADIAL RATING	DYNAMIC AXIAL RATING	DYNAMIC RADIAL RATING	GEAR RATIO	TRACKING PRECISION	WEIGHT
58 kN.m	310 kN.m	247 kN.m	2360 kN	945 kN	590 kN	470 kN	108 : 1	≤ 0.1 °	280 kg
42800 lbf.ft	229×10³ lbf.ft	182.3×10³ lbf.ft	531×10³ lbf	212×10³ lbf	133×10³ lbf	106×10³ lbf			617 lb



All dimensions in mm unless otherwise specified

## FRONT

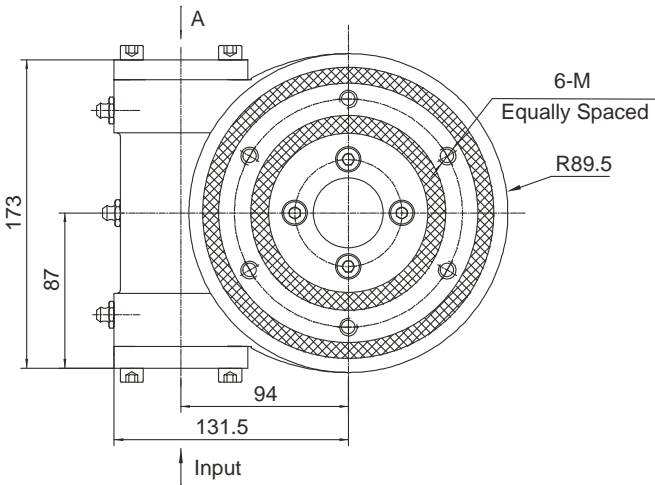

## INPUT

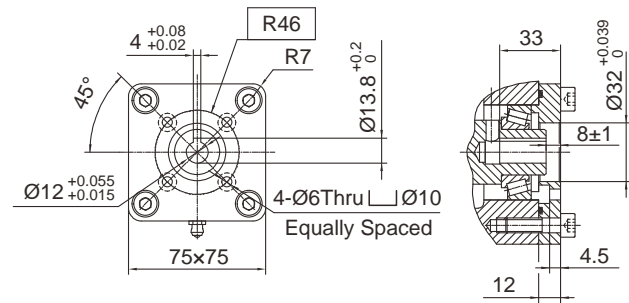

**Ø12**

## SIDE

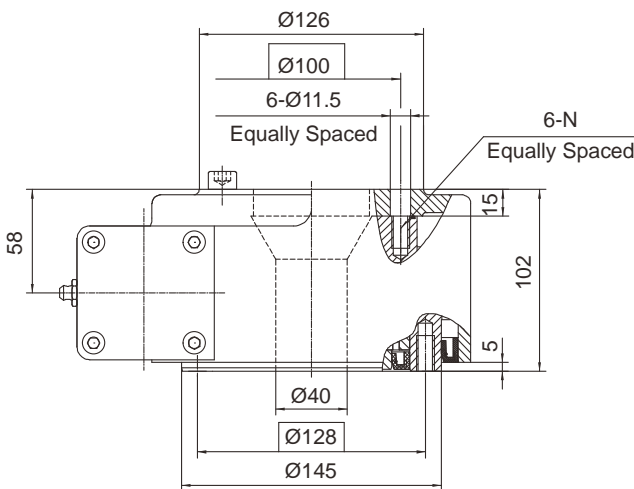

## MOMENT LOAD CHART

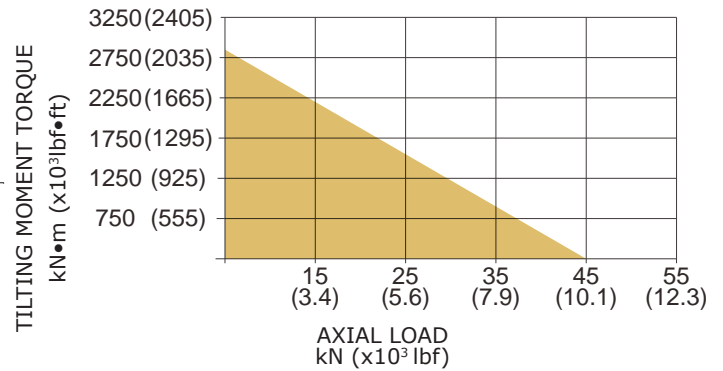

## MOUNTING HOLES OPTION

CODE	M (OUTER RING)	N (INNER RING)
6&7		
- -	M10×1.5 Tap 20	M10×1.5 Tap 18
B -	3/8"-16UNC-2B Tap 20	3/8"-16UNC-2B Tap 18

## PERFORMANCE PARAMETERS

MODEL	OUTPUT TORQUE	TILTING MOMENT TORQUE	HOLDING TORQUE	STATIC AXIAL RATING	STATIC RADIAL RATING	DYNAMIC AXIAL RATING	DYNAMIC RADIAL RATING	GEAR RATIO	TRACKING PRECISION	WEIGHT
SE5C	600 N.m	2800 N.m	5000 N.m	45 kN	22 kN	14.4 kN	11.1 kN	62 : 1	≤ 0.2°	16 kg
	422.5 lbf.ft	2066.4 lbf.ft	3690 lbf.ft	10116 lbf	4945.6 lbf	3237.1 lbf	2495.3 lbf			35 lb
PE5C	600 N.m	2800 N.m	5000 N.m	45 kN	22 kN	14.4 kN	11.1 kN	62 : 1	≤ 0.1°	16 kg
	422.5 lbf.ft	2066.4 lbf.ft	3690 lbf.ft	10116 lbf	4945.6 lbf	3237.1 lbf	2495.3 lbf			35 lb



# Series SE7A/PE7A Dimensions and Ratings

All dimensions in mm unless otherwise specified

## FRONT

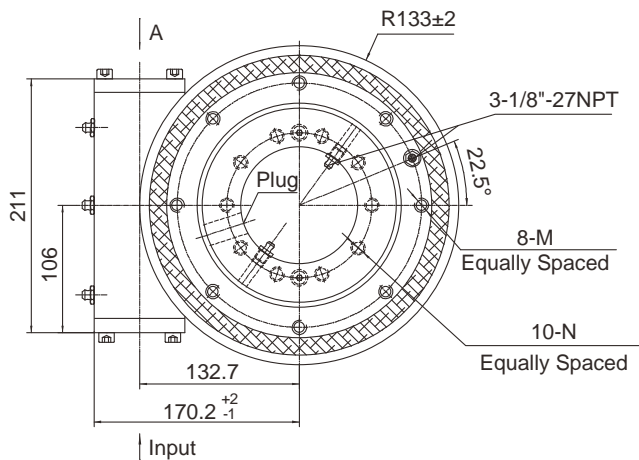

## INPUT

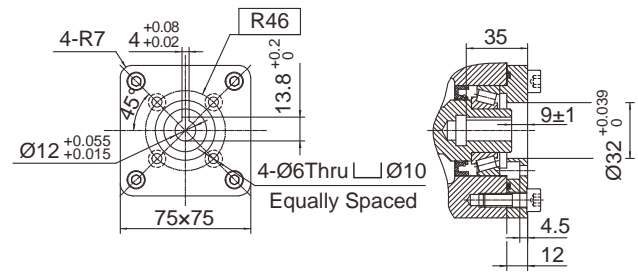

Ø12

## SIDE

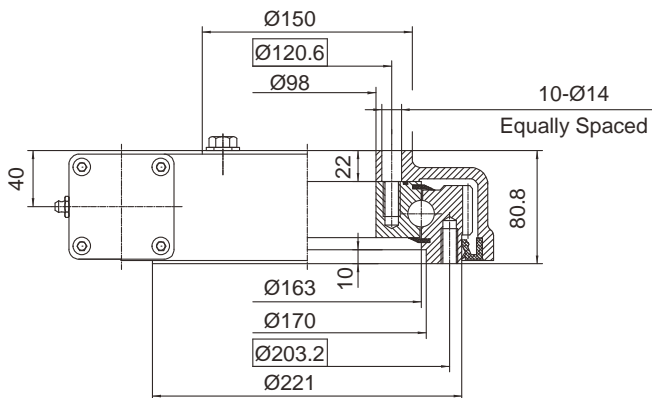

## MOMENT LOAD CHART

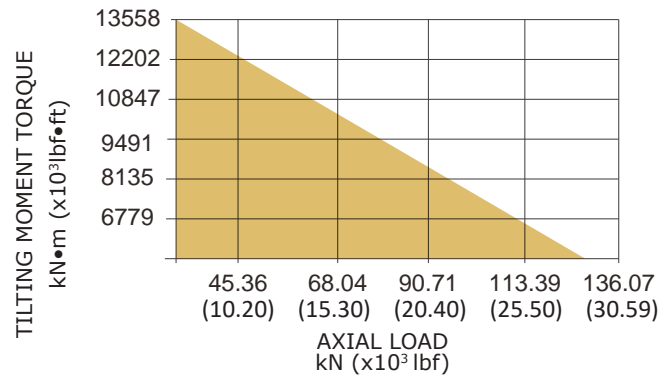

## MOUNTING HOLES OPTION

CODE 6&7	M (OUTER RING)	N (INNER RING)
--	M12×1.75 Tap 25	M12×1.75 Tap 25
-T	M12×1.75 Tap 25	Ø14 Thru
B-	1/2"-13UNC-2B Tap 25	1/2"-13UNC-2B Tap 25
BT	1/2"-13UNC-2B Tap 25	Ø14 Thru

## PERFORMANCE PARAMETERS

MODEL	OUTPUT TORQUE	TILTING MOMENT TORQUE	HOLDING TORQUE	STATIC AXIAL RATING	STATIC RADIAL RATING	DYNAMIC AXIAL RATING	DYNAMIC RADIAL RATING	GEAR RATIO	TRACKING PRECISION	WEIGHT
SE7A	1500 N.m	13500 N.m	10400 N.m	133 kN	53 kN	32 kN	28 kN	73 : 1	≤ 0.2°	25 kg
	1107 lbf.ft	9957 lbf.ft	7671 lbf.ft	29900 lbf	11915 lbf	7194 lbf	6295 lbf			55 lb
PE7A	1500 N.m	13500 N.m	10400 N.m	133 kN	53 kN	32 kN	28 kN	73 : 1	≤ 0.11°	25 kg
	1107 lbf.ft	9957 lbf.ft	7671 lbf.ft	29900 lbf	11915 lbf	7194 lbf	6295 lbf			55 lb

# Series SE9A/PE9A Dimensions and Ratings

All dimensions in mm unless otherwise specified

## FRONT

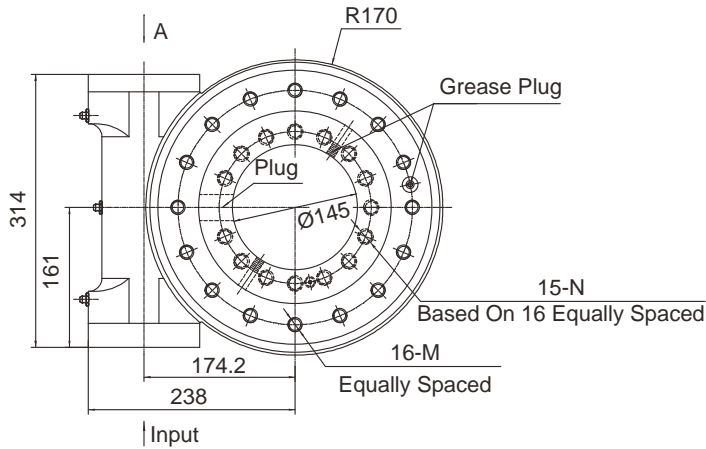

## INPUT

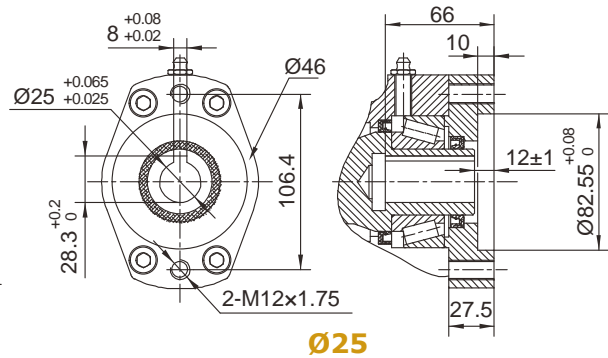

## SIDE

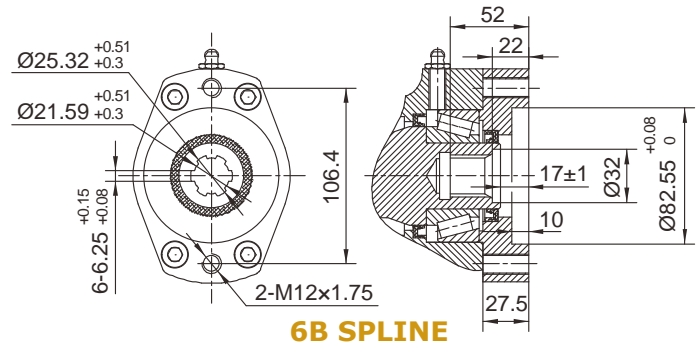
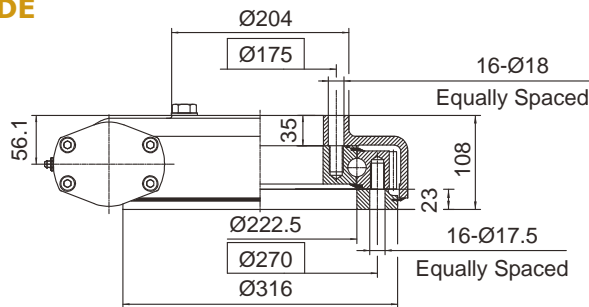

## MOMENT LOAD CHART

## MOUNTING HOLES OPTION

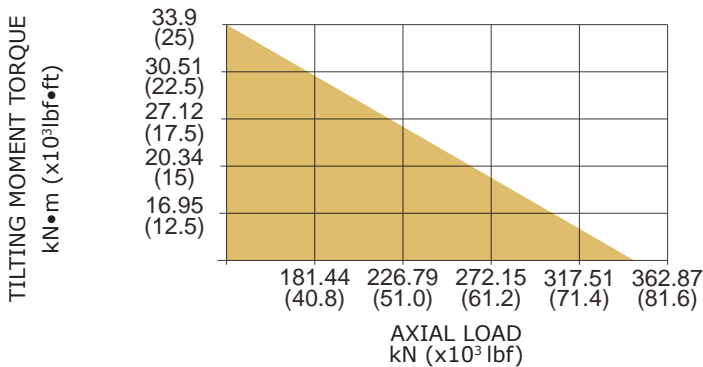

CODE 6&7	M (OUTER RING)	N (INNER RING)
- -	M16×2 Tap 30	M16×2 Tap 30
- T	M16×2 Tap 30	Ø18 Thru
B -	5/8"-11UNC-2B Tap 30	5/8"-11UNC-2B Tap 30
B T	5/8"-11UNC-2B Tap 30	Ø18 Thru

## PERFORMANCE PARAMETERS

MODEL	OUTPUT TORQUE	TILTING MOMENT TORQUE	HOLDING TORQUE	STATIC AXIAL RATING	STATIC RADIAL RATING	DYNAMIC AXIAL RATING	DYNAMIC RADIAL RATING	GEAR RATIO	TRACKING PRECISION	WEIGHT
SE9A	6.5 kN.m	33.9 kN.m	34.5 kN.m	338 kN	135 kN	81 kN	71 kN	61 : 1	≤ 0.17°	49 kg
	4794 lbf.ft	25×10 <sup>3</sup> lbf.ft	25.5×10 <sup>3</sup> lbf.ft	76×10 <sup>3</sup> lbf	30×10 <sup>3</sup> lbf	18×10 <sup>3</sup> lbf	16×10 <sup>3</sup> lbf			108 lb
PE9A	6.5 kN.m	33.9 kN.m	34.5 kN.m	338 kN	135 kN	81 kN	71 kN	61 : 1	≤ 0.09°	49 kg
	4794 lbf.ft	25×10 <sup>3</sup> lbf.ft	25.5×10 <sup>3</sup> lbf.ft	76×10 <sup>3</sup> lbf	30×10 <sup>3</sup> lbf	18×10 <sup>3</sup> lbf	16×10 <sup>3</sup> lbf			108 lb

# Series SE12A/PE12A Dimensions and Ratings

All dimensions in mm unless otherwise specified

## FRONT

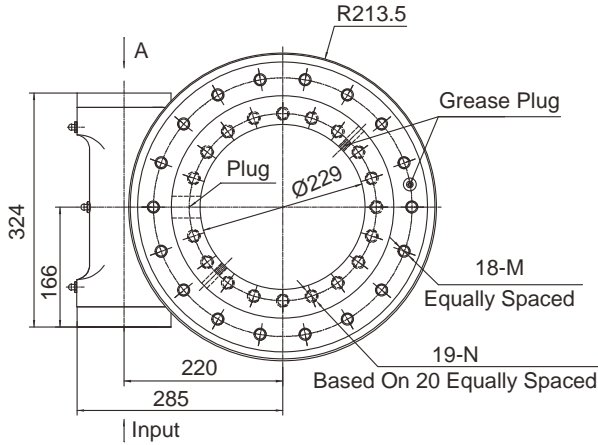

## INPUT

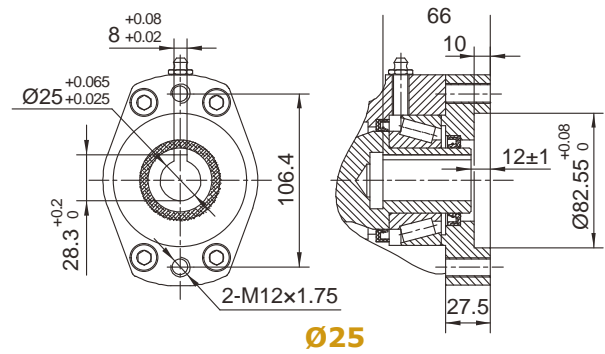

## SIDE

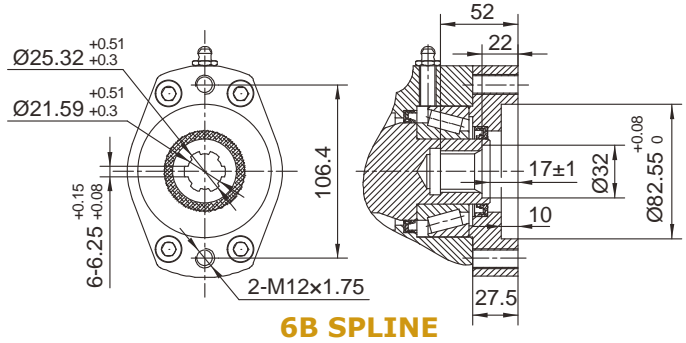
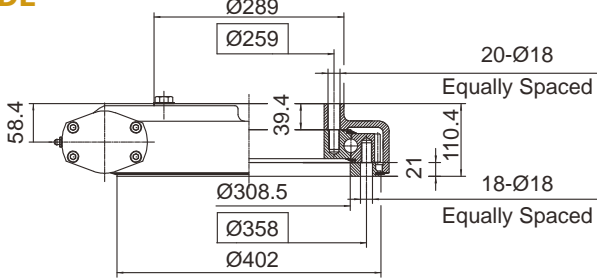

## MOMENT LOAD CHART

## MOUNTING HOLES OPTION

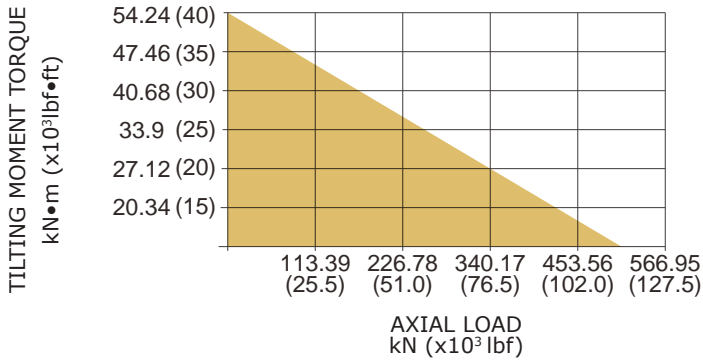

CODE 6&7	M (OUTER RING)	N (INNER RING)
--	M16×2 Tap 30	M16×2 Tap 30
- T	M16×2 Tap 30	Ø18 Thru
B -	5/8"-11UNC-2B Tap 30	5/8"-11UNC-2B Tap 30
B T	5/8"-11UNC-2B Tap 30	Ø18 Thru

## PERFORMANCE PARAMETERS

MODEL	OUTPUT TORQUE	TILTING MOMENT TORQUE	HOLDING TORQUE	STATIC AXIAL RATING	STATIC RADIAL RATING	DYNAMIC AXIAL RATING	DYNAMIC RADIAL RATING	GEAR RATIO	TRACKING PRECISION	WEIGHT
SE12A	7.5 kN.m	54.3 kN.m	43 kN.m	475 kN	190 kN	114 kN	100 kN	78 : 1	≤ 0.17°	61 kg
	5532 lbf.ft	40×10 <sup>3</sup> lbf.ft	32×10 <sup>3</sup> lbf.ft	107×10 <sup>3</sup> lbf	43×10 <sup>3</sup> lbf	26×10 <sup>3</sup> lbf	23×10 <sup>3</sup> lbf			134 lb
PE12A	7.5 kN.m	54.3 kN.m	43 kN.m	475 kN	190 kN	114 kN	100 kN	78 : 1	≤ 0.07°	61 kg
	5532 lbf.ft	40×10 <sup>3</sup> lbf.ft	32×10 <sup>3</sup> lbf.ft	107×10 <sup>3</sup> lbf	43×10 <sup>3</sup> lbf	26×10 <sup>3</sup> lbf	23×10 <sup>3</sup> lbf			134 lb

All dimensions in mm unless otherwise specified

## FRONT

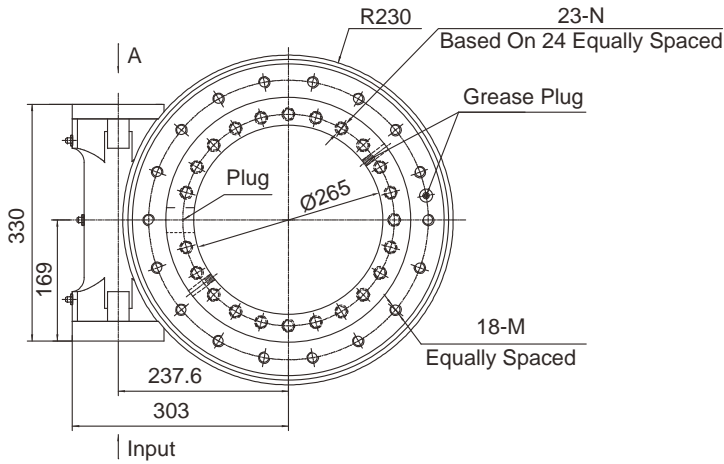

## INPUT

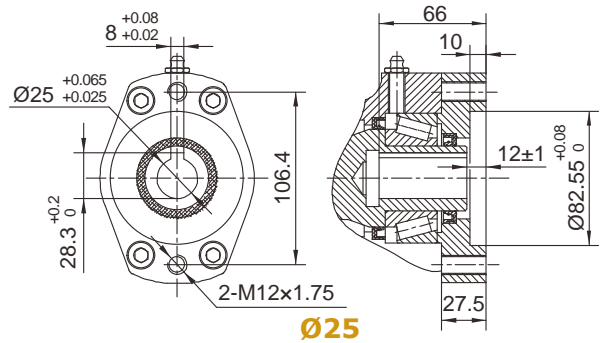

## SIDE

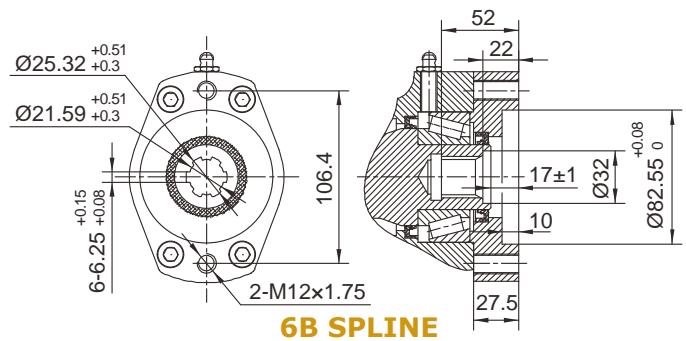
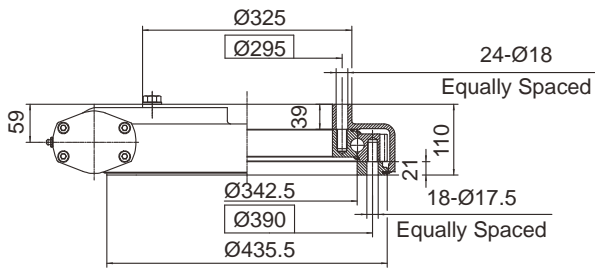

## MOMENT LOAD CHART

## MOUNTING HOLES OPTION

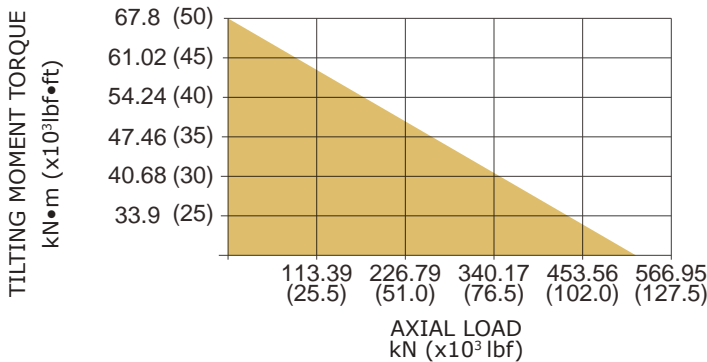

CODE 6&7	M (OUTER RING)	N (INNER RING)
- -	M16×2 Tap 30	M16×2 Tap 30
- T	M16×2 Tap 30	Ø18 Thru
B -	5/8"-11UNC-2B Tap 30	5/8"-11UNC-2B Tap 30
B T	5/8"-11UNC-2B Tap 30	Ø18 Thru

## PERFORMANCE PARAMETERS

MODEL	OUTPUT TORQUE	TILTING MOMENT TORQUE	HOLDING TORQUE	STATIC AXIAL RATING	STATIC RADIAL RATING	DYNAMIC AXIAL RATING	DYNAMIC RADIAL RATING	GEAR RATIO	TRACKING PRECISION	WEIGHT
SE14A	8 kN.m	67.8 kN.m	48 kN.m	555 kN	222 kN	133 kN	117 kN	85 : 1	≤ 0.17°	64 kg
	5900 lbf.ft	50×10³ lbf.ft	35×10³ lbf.ft	125×10³ lbf	50×10³ lbf	30×10³ lbf	26×10³ lbf			141 lb
PE14A	8 kN.m	67.8 kN.m	48 kN.m	555 kN	222 kN	133 kN	117 kN	85 : 1	≤ 0.09°	64 kg
	5900 lbf.ft	50×10³ lbf.ft	35×10³ lbf.ft	125×10³ lbf	50×10³ lbf	30×10³ lbf	26×10³ lbf			141 lb

# Series SE17A/PE17A Dimensions and Ratings

All dimensions in mm unless otherwise specified

## FRONT

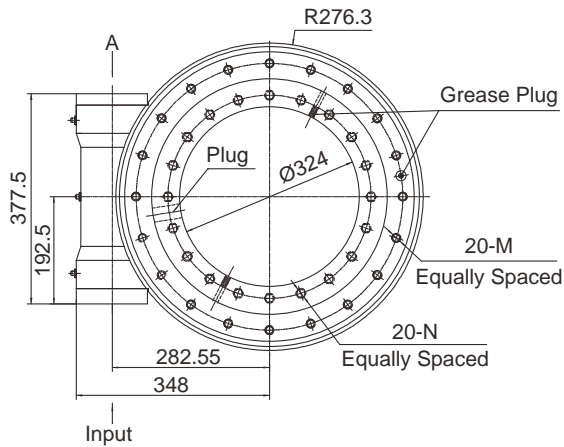

## INPUT

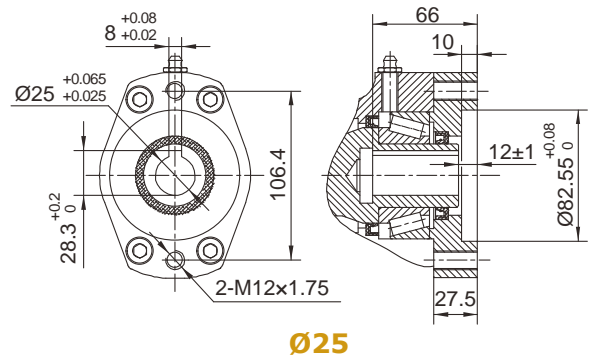

## SIDE

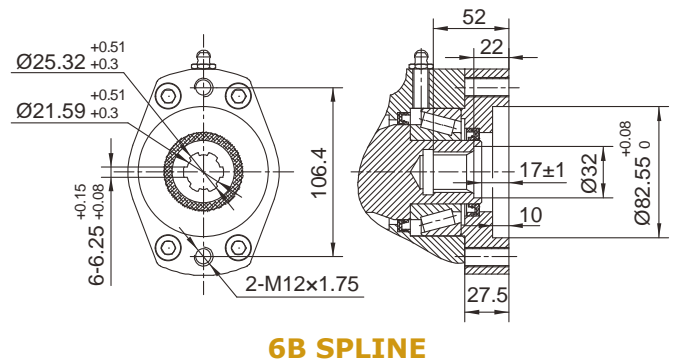
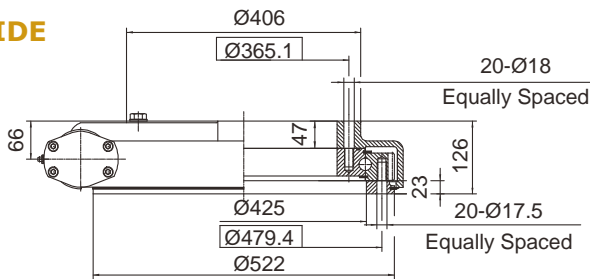

## MOMENT LOAD CHART

## MOUNTING HOLES OPTION

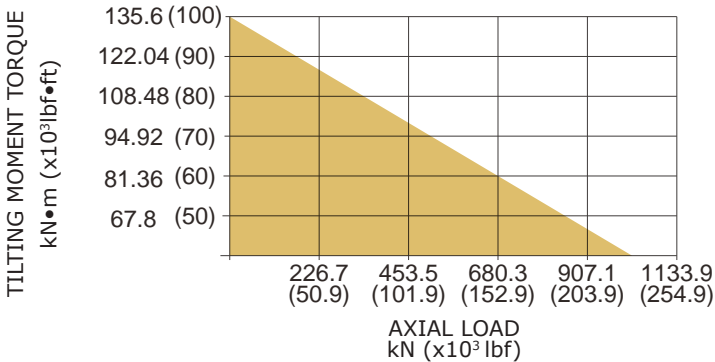

CODE 6&7	M (OUTER RING)	N (INNER RING)
- -	M16×2 Tap 32	M16×2 Tap 32
- T	M16×2 Tap 32	Ø18 Thru
B -	5/8"-11UNC-2B Tap 32	5/8"-11UNC-2B Tap 32
B T	5/8"-11UNC-2B Tap 32	Ø18 Thru

## PERFORMANCE PARAMETERS

MODEL	OUTPUT TORQUE	TILTING MOMENT TORQUE	HOLDING TORQUE	STATIC AXIAL RATING	STATIC RADIAL RATING	DYNAMIC AXIAL RATING	DYNAMIC RADIAL RATING	GEAR RATIO	TRACKING PRECISION	WEIGHT
SE17A	10 kN.m	135.6 kN.m	58 kN.m	970 kN	390 kN	235 kN	205 kN	102 : 1	≤ 0.15°	105 kg
	7400 lbf.ft	100×10³ lbf.ft	42.8×10³ lbf.ft	218×10³ lbf	88×10³ lbf	53×10³ lbf	46×10³ lbf			231 lb
PE17A	10 kN.m	135.6 kN.m	58 kN.m	970 kN	390 kN	235 kN	205 kN	102 : 1	≤ 0.09°	105 kg
	7400 lbf.ft	100×10³ lbf.ft	42.8×10³ lbf.ft	218×10³ lbf	88×10³ lbf	53×10³ lbf	46×10³ lbf			231 lb

All dimensions in mm unless otherwise specified

## FRONT

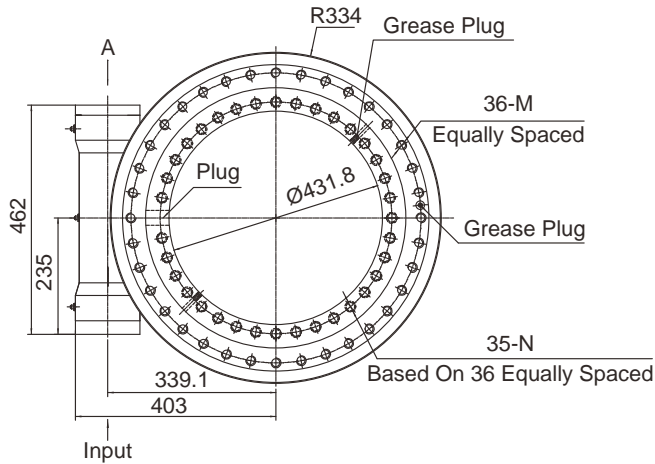

## INPUT

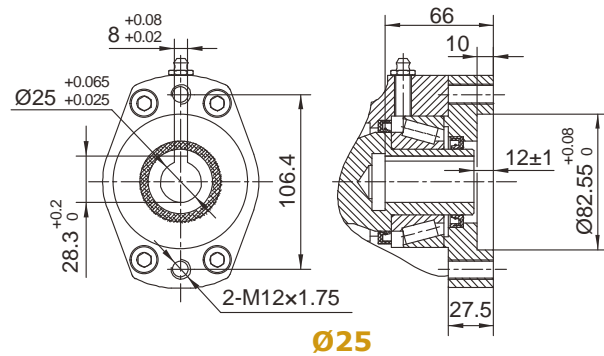

## SIDE

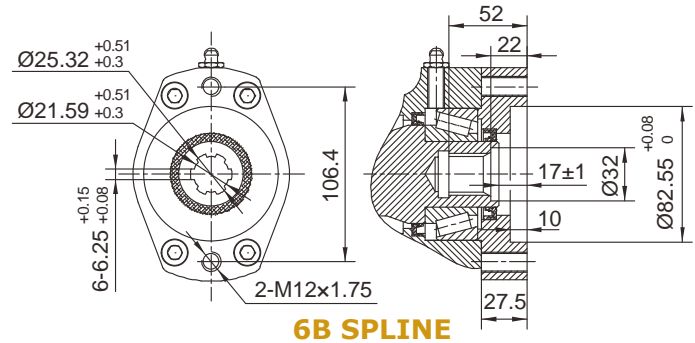
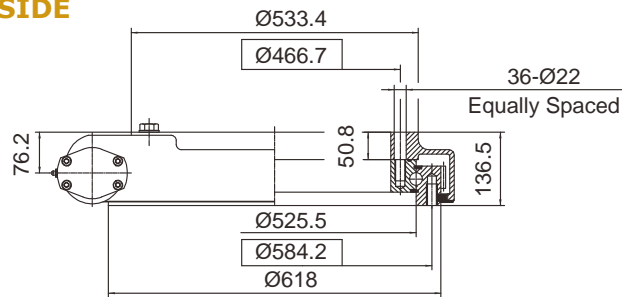

## MOMENT LOAD CHART

## MOUNTING HOLES OPTION

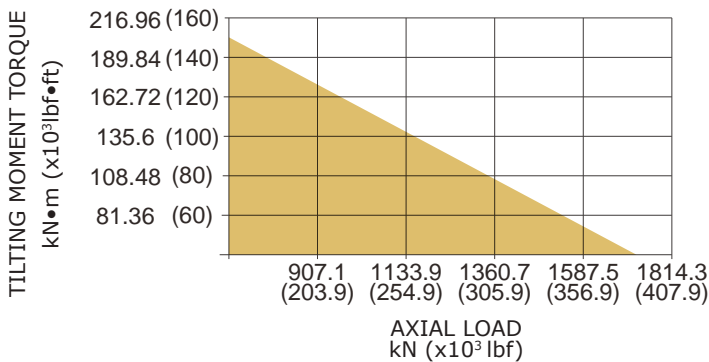

CODE 6&7	M (OUTER RING)	N (INNER RING)
- -	M20×2.5 Tap 40	M20×2.5 Tap 40
- T	M20×2.5 Tap 40	Ø22 Thru
B -	3/4"-10UNC-2B Tap 40	3/4"-10UNC-2B Tap 40
B T	3/4"-10UNC-2B Tap 40	Ø22 Thru

## PERFORMANCE PARAMETERS

MODEL	OUTPUT TORQUE	TILTING MOMENT TORQUE	HOLDING TORQUE	STATIC AXIAL RATING	STATIC RADIAL RATING	DYNAMIC AXIAL RATING	DYNAMIC RADIAL RATING	GEAR RATIO	TRACKING PRECISION	WEIGHT
SE21	15 kN.m	203 kN.m	70.5 kN.m	1598 kN	640 kN	385 kN	335 kN	125 : 1	≤ 0.15°	149 kg
	11000 lbf.ft	150×10 <sup>3</sup> lbf.ft	52×10 <sup>3</sup> lbf.ft	359×10 <sup>3</sup> lbf	144×10 <sup>3</sup> lbf	87×10 <sup>3</sup> lbf	75×10 <sup>3</sup> lbf			328 lb
PE21	15 kN.m	203 kN.m	105.8 kN.m	1598 kN	640 kN	385 kN	335 kN	125 : 1	≤ 0.09°	149 kg
	11000 lbf.ft	150×10 <sup>3</sup> lbf.ft	78×10 <sup>3</sup> lbf.ft	359×10 <sup>3</sup> lbf	144×10 <sup>3</sup> lbf	87×10 <sup>3</sup> lbf	75×10 <sup>3</sup> lbf			328 lb

# Series SE25/PE25 Dimensions and Ratings

All dimensions in mm unless otherwise specified

## FRONT

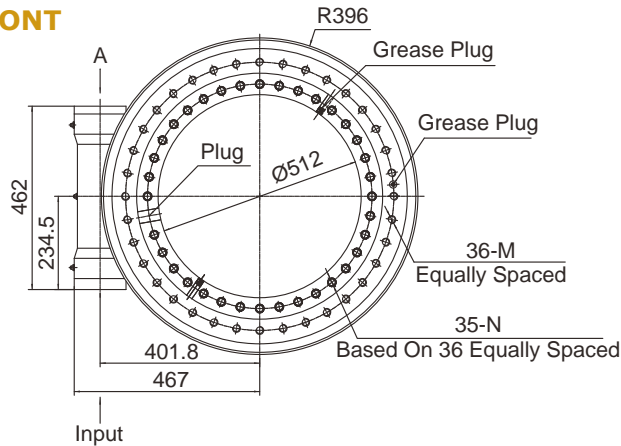

## INPUT

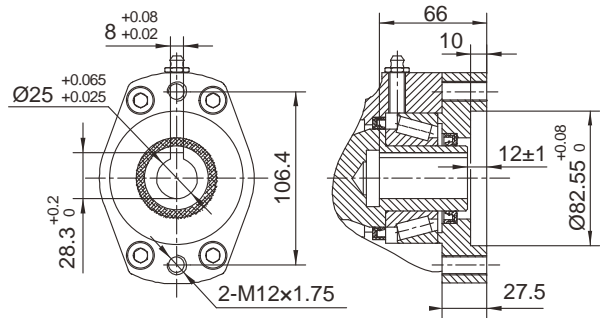

## Ø25

## SIDE

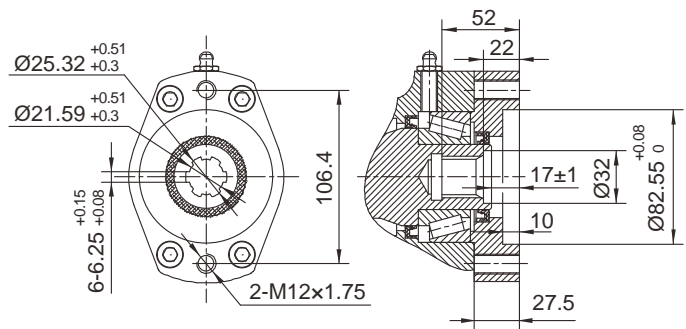
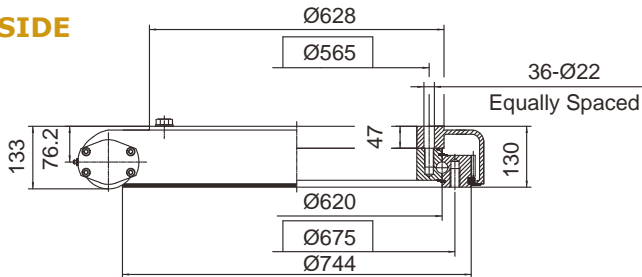

## 6B SPLINE

## MOMENT LOAD CHART

## MOUNTING HOLES OPTION

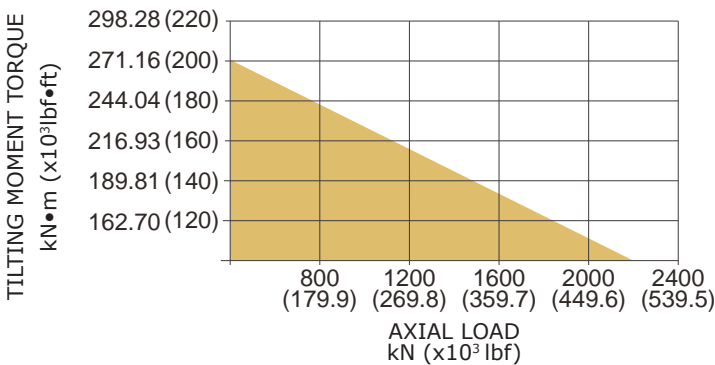

CODE 6&7	M (OUTER RING)	N (INNER RING)
--	M20×2.5 Tap 40	M20×2.5 Tap 40
- T	M20×2.5 Tap 40	Ø22 Thru
B -	3/4"-10UNC-2B Tap 40	3/4"-10UNC-2B Tap 40
B T	3/4"-10UNC-2B Tap 40	Ø22 Thru

## PERFORMANCE PARAMETERS

MODEL	OUTPUT TORQUE	TILTING MOMENT TORQUE	HOLDING TORQUE	STATIC AXIAL RATING	STATIC RADIAL RATING	DYNAMIC AXIAL RATING	DYNAMIC RADIAL RATING	GEAR RATIO	TRACKING PRECISION	WEIGHT
SE25	18 kN.m	271 kN.m	84.5 kN.m	2360 kN	945 kN	590 kN	470 kN	150 : 1	≤ 0.15°	204 kg
	13300 lbf.ft	200×10 <sup>3</sup> lbf.ft	62.4×10 <sup>3</sup> lbf.ft	531×10 <sup>3</sup> lbf	212×10 <sup>3</sup> lbf	133×10 <sup>3</sup> lbf	106×10 <sup>3</sup> lbf			450 lb
PE25	18 kN.m	271 kN.m	84.5 kN.m	2360 kN	945 kN	590 kN	470 kN	150 : 1	≤ 0.09°	204 kg
	13300 lbf.ft	200×10 <sup>3</sup> lbf.ft	62.4×10 <sup>3</sup> lbf.ft	531×10 <sup>3</sup> lbf	212×10 <sup>3</sup> lbf	133×10 <sup>3</sup> lbf	106×10 <sup>3</sup> lbf			450 lb



All dimensions in mm unless otherwise specified

## FRONT

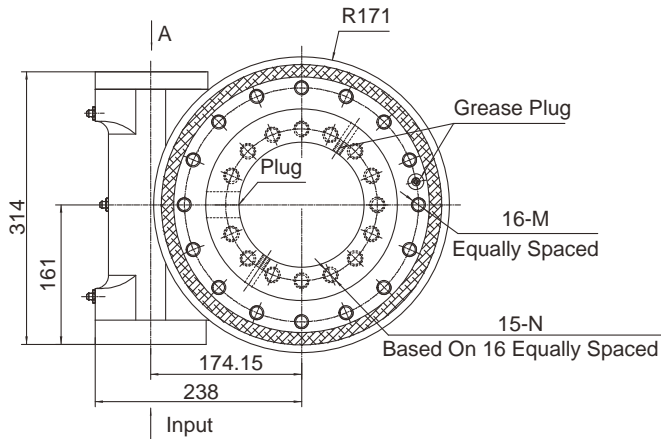

## INPUT

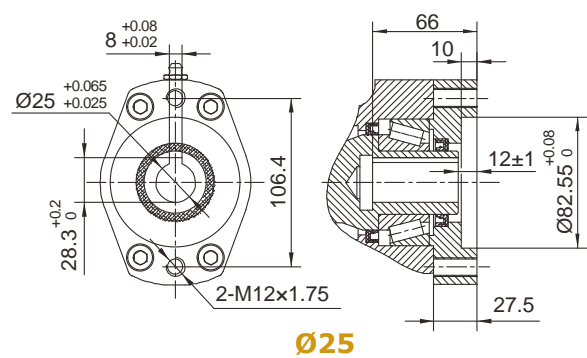

## SIDE

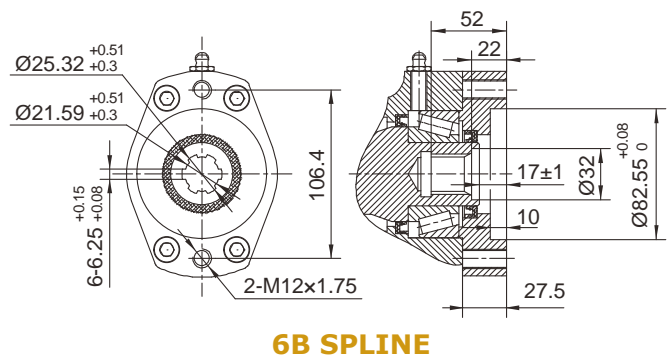
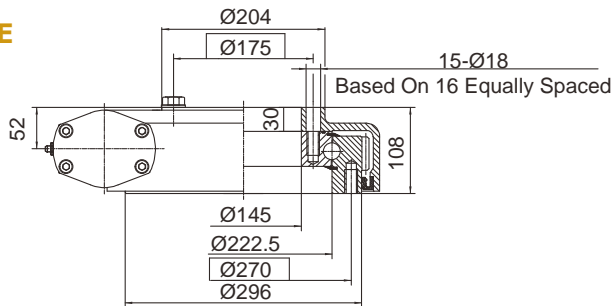

## MOMENT LOAD CHART

## MOUNTING HOLES OPTION

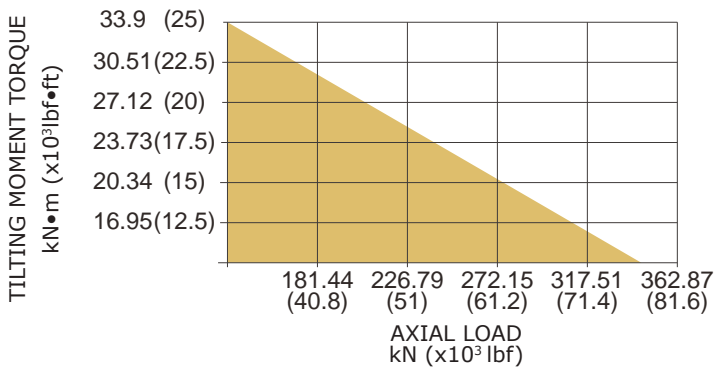

CODE 6&7	M (OUTER RING)	N (INNER RING)
- -	M16×2 Tap 30	M16×2 Tap 30
- T	M16×2 Tap 30	Ø18 Thru
B -	5/8"-11UNC-2B Tap 30	5/8"-11UNC-2B Tap 30
B T	5/8"-11UNC-2B Tap 30	Ø18 Thru

## PERFORMANCE PARAMETERS

MODEL	OUTPUT TORQUE	TILTING MOMENT TORQUE	HOLDING TORQUE	STATIC AXIAL RATING	STATIC RADIAL RATING	DYNAMIC AXIAL RATING	DYNAMIC RADIAL RATING	GEAR RATIO	TRACKING PRECISION	WEIGHT
SEA9	6.5 kN.m	33.9 kN.m	34.5 kN.m	338 kN	135 kN	81 kN	71 kN	61 : 1	≤ 0.17°	48 kg
	4794 lbf.ft	25×10³ lbf.ft	25.5×10³ lbf.ft	76×10³ lbf	30×10³ lbf	18×10³ lbf	16×10³ lbf			106 lb
PEA9	6.5 kN.m	33.9 kN.m	34.5 kN.m	338 kN	135 kN	81 kN	71 kN	61 : 1	≤ 0.09°	48 kg
	4794 lbf.ft	25×10³ lbf.ft	25.5×10³ lbf.ft	76×10³ lbf	30×10³ lbf	18×10³ lbf	16×10³ lbf			106 lb

# Series SEA12/PEA12 Dimensions and Ratings

All dimensions in mm unless otherwise specified

## FRONT

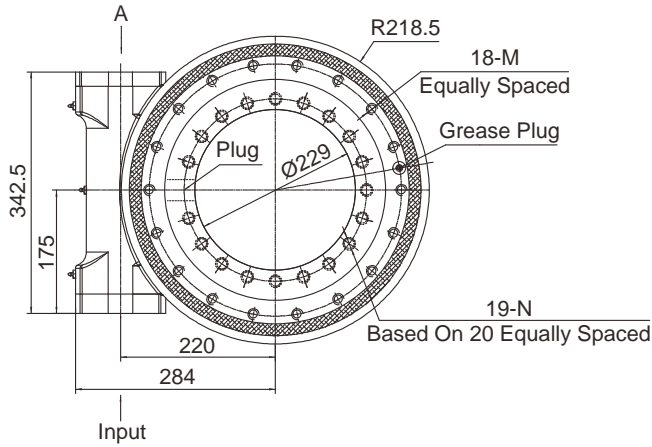

## INPUT

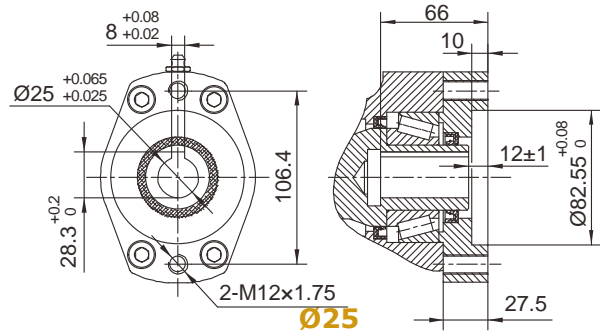

## SIDE

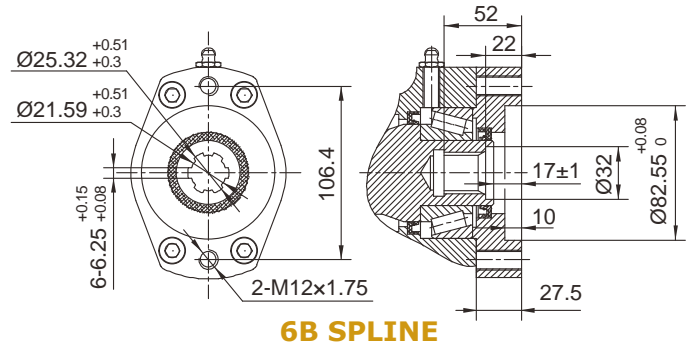
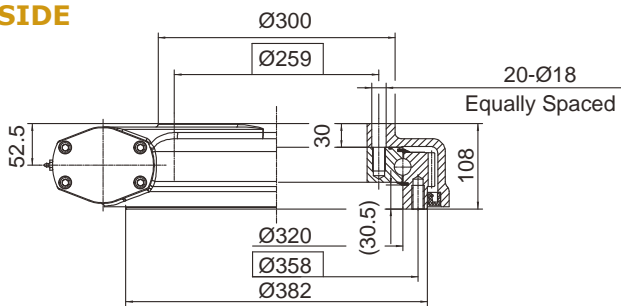

## MOMENT LOAD CHART

## MOUNTING HOLES OPTION

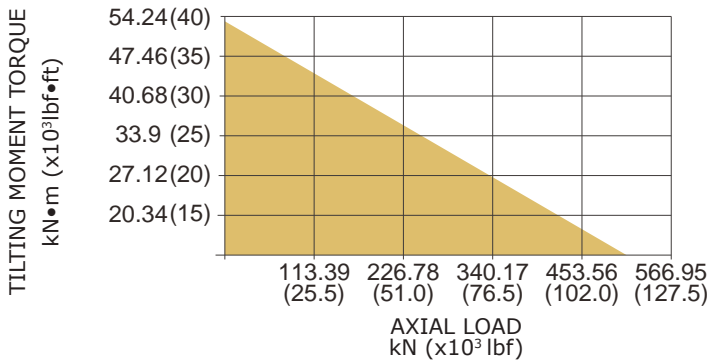

CODE 6&7	M (OUTER RING)	N (INNER RING)
--	M16×2 Tap 30	M16×2 Tap 30
- T	M16×2 Tap 30	Ø18 Thru
B -	5/8"-11UNC-2B Tap 30	5/8"-11UNC-2B Tap 30
B T	5/8"-11UNC-2B Tap 30	Ø18 Thru

## PERFORMANCE PARAMETERS

MODEL	OUTPUT TORQUE	TILTING MOMENT TORQUE	HOLDING TORQUE	STATIC AXIAL RATING	STATIC RADIAL RATING	DYNAMIC AXIAL RATING	DYNAMIC RADIAL RATING	GEAR RATIO	TRACKING PRECISION	WEIGHT
SEA12	7.5 kN.m	54.3 kN.m	43 kN.m	475 kN	190 kN	114 kN	100 kN	78 : 1	≤ 0.17°	63 kg
	5532 lbf.ft	40×10 <sup>3</sup> lbf.ft	32×10 <sup>3</sup> lbf.ft	107×10 <sup>3</sup> lbf	43×10 <sup>3</sup> lbf	26×10 <sup>3</sup> lbf	23×10 <sup>3</sup> lbf			139 lb
PEA12	7.5 kN.m	54.3 kN.m	43 kN.m	475 kN	190 kN	114 kN	100 kN	78 : 1	≤ 0.07°	63 kg
	5532 lbf.ft	40×10 <sup>3</sup> lbf.ft	32×10 <sup>3</sup> lbf.ft	107×10 <sup>3</sup> lbf	43×10 <sup>3</sup> lbf	26×10 <sup>3</sup> lbf	23×10 <sup>3</sup> lbf			139 lb

All dimensions in mm unless otherwise specified

## FRONT

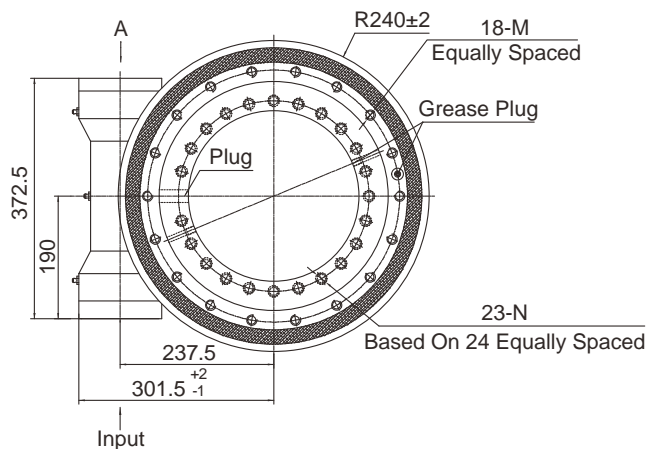

## INPUT

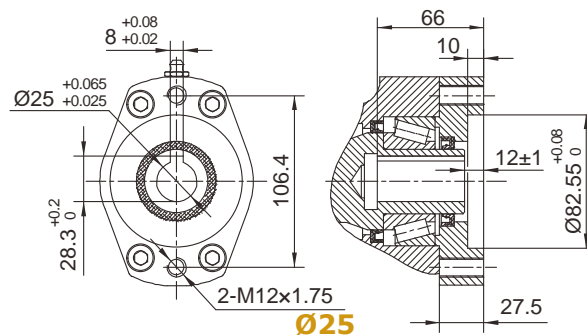

## SIDE

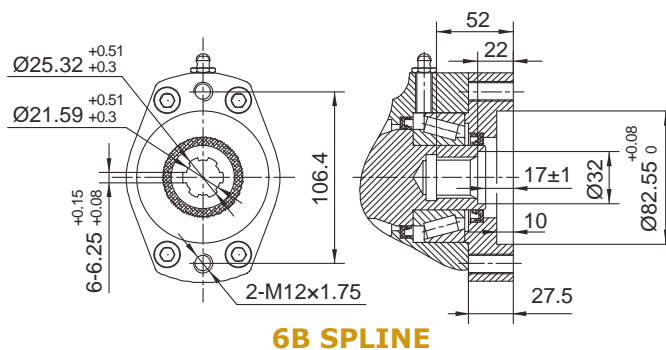
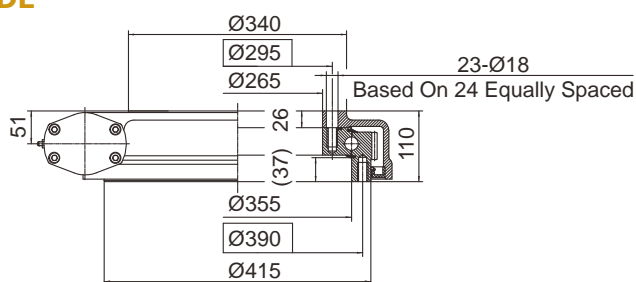

## MOMENT LOAD CHART

## MOUNTING HOLES OPTION

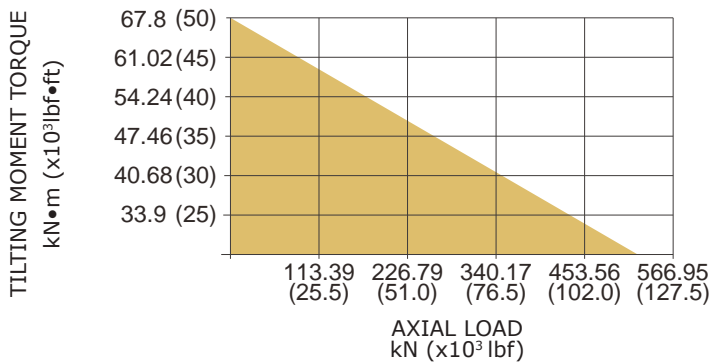

CODE 6&7	M (OUTER RING)	N (INNER RING)
- -	M16×2 Tap 30	M16×2 Tap 30
- T	M16×2 Tap 30	Ø18 Thru
B -	5/8"-11UNC-2B Tap 30	5/8"-11UNC-2B Tap 30
B T	5/8"-11UNC-2B Tap 30	Ø18 Thru

## PERFORMANCE PARAMETERS

MODEL	OUTPUT TORQUE	TILTING MOMENT TORQUE	HOLDING TORQUE	STATIC AXIAL RATING	STATIC RADIAL RATING	DYNAMIC AXIAL RATING	DYNAMIC RADIAL RATING	GEAR RATIO	TRACKING PRECISION	WEIGHT
SEA14	8 kN.m	67.8 kN.m	48 kN.m	555 kN	222 kN	133 kN	117 kN	85 : 1	≤ 0.17°	64 kg
	5900 lbf.ft	50×10 <sup>3</sup> lbf.ft	35×10 <sup>3</sup> lbf.ft	125×10 <sup>3</sup> lbf	50×10 <sup>3</sup> lbf	30×10 <sup>3</sup> lbf	26×10 <sup>3</sup> lbf			141 lb
PEA14	8 kN.m	67.8 kN.m	48 kN.m	555 kN	222 kN	133 kN	117 kN	85 : 1	≤ 0.09°	64 kg
	5900 lbf.ft	50×10 <sup>3</sup> lbf.ft	35×10 <sup>3</sup> lbf.ft	125×10 <sup>3</sup> lbf	50×10 <sup>3</sup> lbf	30×10 <sup>3</sup> lbf	26×10 <sup>3</sup> lbf			141 lb



All dimensions in mm unless otherwise specified

## FRONT

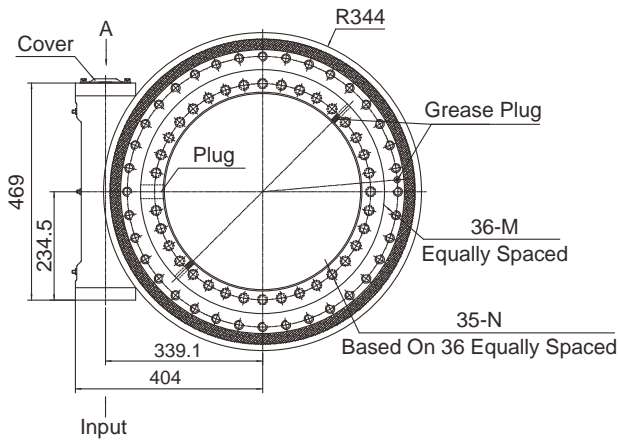

## INPUT

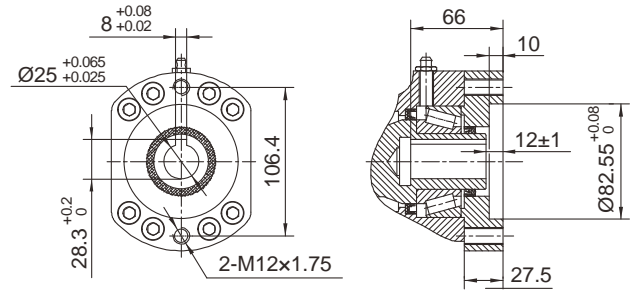

**Ø25**

## SIDE

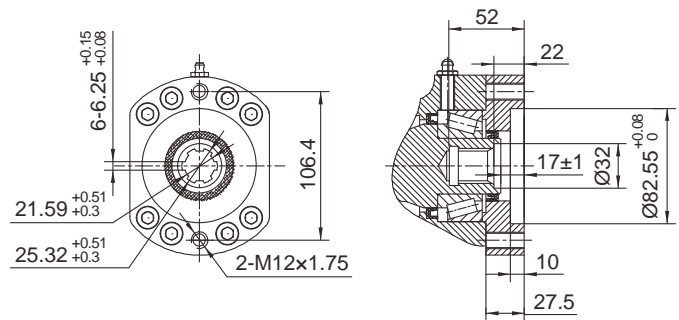
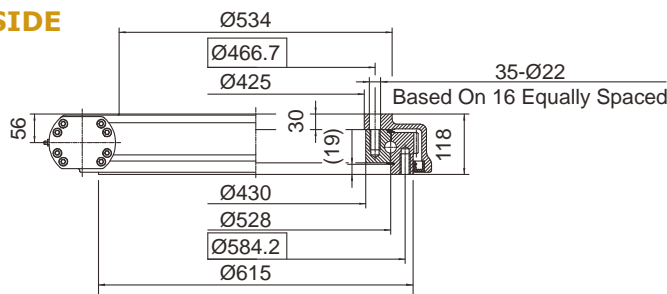

**6B SPLINE**

## MOMENT LOAD CHART

## MOUNTING HOLES OPTION

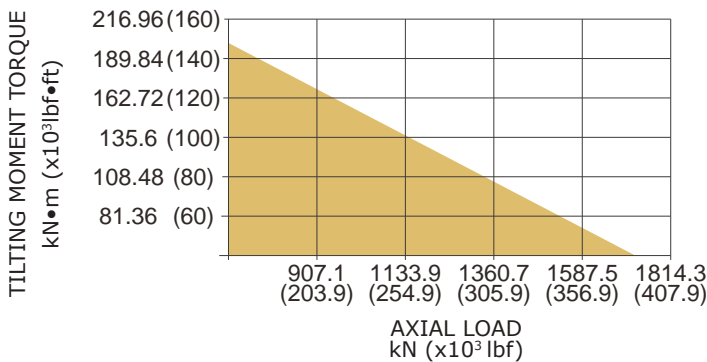

CODE	M (OUTER RING)	N (INNER RING)
6&7	M20×2.5 Tap 40	M20×2.5 Tap 40
- T	M20×2.5 Tap 40	Ø22 Thru
B -	3/4"-10UNC-2B Tap 40	3/4"-10UNC-2B Tap 40
B T	3/4"-10UNC-2B Tap 40	Ø22 Thru

## PERFORMANCE PARAMETERS

MODEL	OUTPUT TORQUE	TILTING MOMENT TORQUE	HOLDING TORQUE	STATIC AXIAL RATING	STATIC RADIAL RATING	DYNAMIC AXIAL RATING	DYNAMIC RADIAL RATING	GEAR RATIO	TRACKING PRECISION	WEIGHT
SEA21	15 kN.m	203 kN.m	70.5 kN.m	1598 kN	640 kN	385 kN	335 kN	125 : 1	≤ 0.15°	140 kg
	11000 lbf.ft	150×10 <sup>3</sup> lbf.ft	52×10 <sup>3</sup> lbf.ft	359×10 <sup>3</sup> lbf	144×10 <sup>3</sup> lbf	87×10 <sup>3</sup> lbf	75×10 <sup>3</sup> lbf			309 lb
PEA21	15 kN.m	203 N.m	70.5 kN.m	1598 kN	640 kN	385 kN	335 kN	125 : 1	≤ 0.09°	140 kg
	11000 lbf.ft	150×10 <sup>3</sup> lbf.ft	52×10 <sup>3</sup> lbf.ft	359×10 <sup>3</sup> lbf	144×10 <sup>3</sup> lbf	87×10 <sup>3</sup> lbf	75×10 <sup>3</sup> lbf			309 lb

# Series SEA25/PEA25 Dimensions and Ratings

All dimensions in mm unless otherwise specified

## FRONT

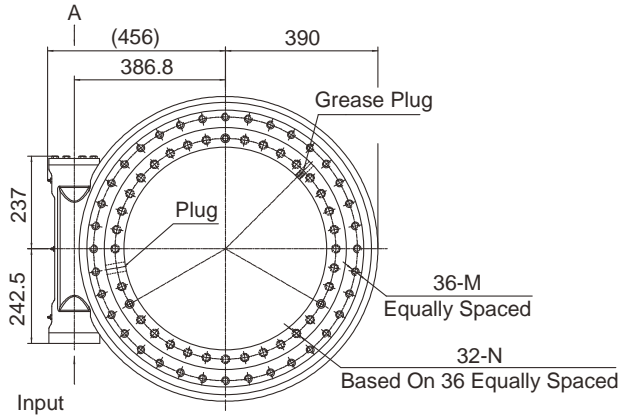

## INPUT

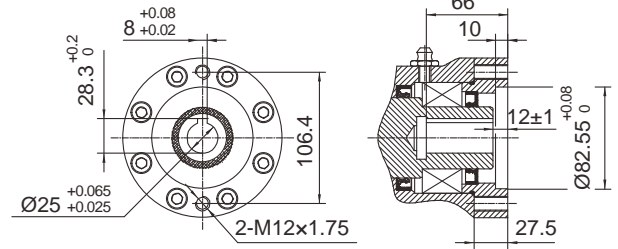

## Ø25

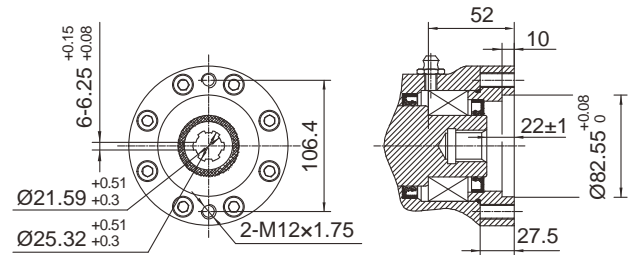

## 6B SPLINE

## SIDE

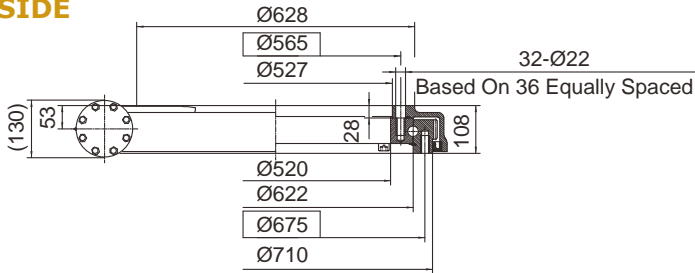

## MOMENT LOAD CHART

## MOUNTING HOLES OPTION

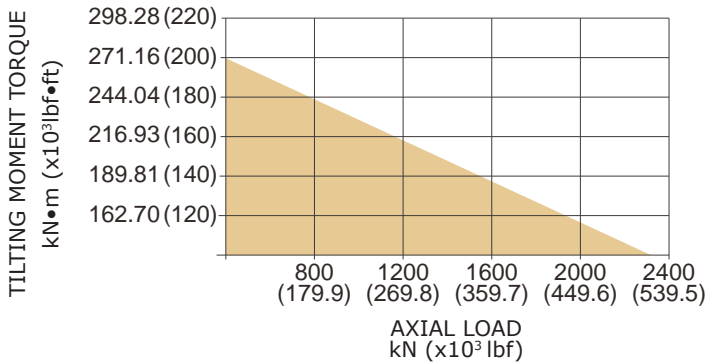

CODE	M (OUTER RING)	N (INNER RING)
6&7	M20×2.5 Tap 40	M20×2.5 Tap 40
- T	M20×2.5 Tap 40	Ø22 Thru
B -	3/4"-10UNC-2B Tap 40	3/4"-10UNC-2B Tap 40
B T	3/4"-10UNC-2B Tap 40	Ø22 Thru

## PERFORMANCE PARAMETERS

MODEL	OUTPUT TORQUE	TILTING MOMENT TORQUE	HOLDING TORQUE	STATIC AXIAL RATING	STATIC RADIAL RATING	DYNAMIC AXIAL RATING	DYNAMIC RADIAL RATING	GEAR RATIO	TRACKING PRECISION	WEIGHT
SEA25	18 kN.m	270 kN.m	84.5 kN.m	2360 kN	945 kN	590 kN	470 kN	150 : 1	≤ 0.15°	165 kg
	13300 lbf.ft	200×10 <sup>3</sup> lbf.ft	62.4×10 <sup>3</sup> lbf.ft	531×10 <sup>3</sup> lbf	212×10 <sup>3</sup> lbf	133×10 <sup>3</sup> lbf	106×10 <sup>3</sup> lbf			364 lb
PEA25	18 kN.m	270 kN.m	84.5 kN.m	2360 kN	945 kN	590 kN	470 kN	150 : 1	≤ 0.09°	165 kg
	13300 lbf.ft	200×10 <sup>3</sup> lbf.ft	62.4×10 <sup>3</sup> lbf.ft	531×10 <sup>3</sup> lbf	212×10 <sup>3</sup> lbf	133×10 <sup>3</sup> lbf	106×10 <sup>3</sup> lbf			364 lb

# Series SEB7/PEB7 Dimensions and Ratings

All dimensions in mm unless otherwise specified

## FRONT

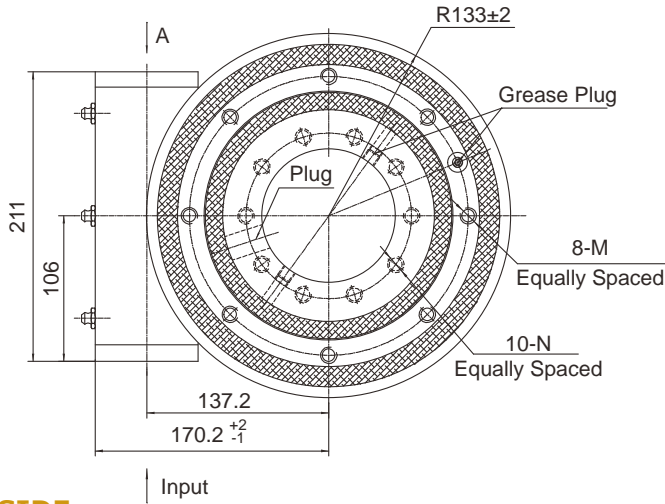

## SIDE

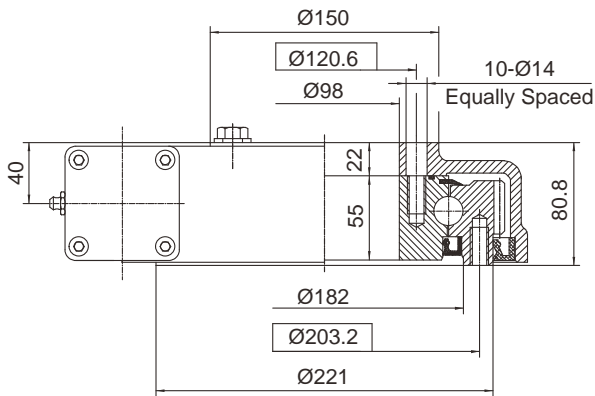

## INPUT

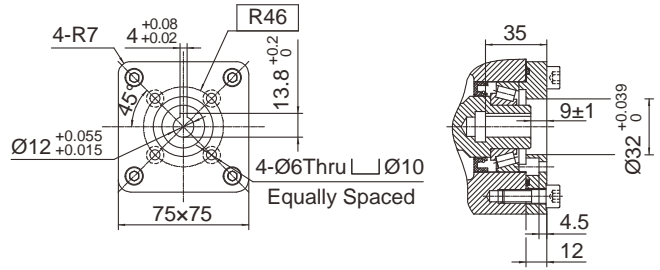

Ø12

## MOMENT LOAD CHART

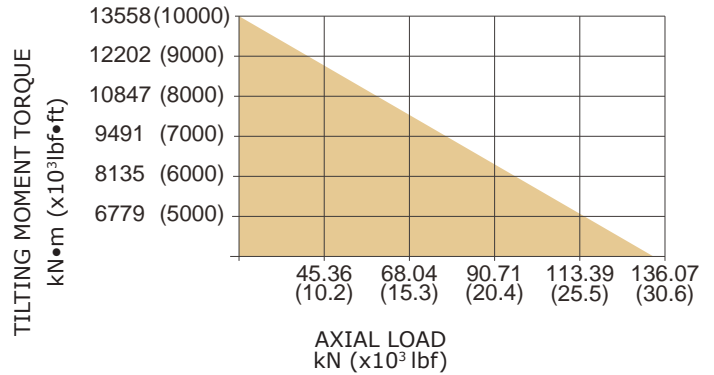

## MOUNTING HOLES OPTION

CODE 6&7	M (OUTER RING)	N (INNER RING)
--	M12×1.75 Tap 25	M12×1.75 Tap 25
-T	M12×1.75 Tap 25	Ø14 Thru
B-	1/2"-13UNC-2B Tap 25	1/2"-13UNC-2B Tap 25
BT	1/2"-13UNC-2B Tap 25	Ø14 Thru

## PERFORMANCE PARAMETERS

MODEL	OUTPUT TORQUE	TILTING MOMENT TORQUE	HOLDING TORQUE	STATIC AXIAL RATING	STATIC RADIAL RATING	DYNAMIC AXIAL RATING	DYNAMIC RADIAL RATING	GEAR RATIO	TRACKING PRECISION	WEIGHT
SEB7	1500 N.m	13500 N.m	10400 N.m	133 kN	53 kN	32 kN	28 kN	73 : 1	≤ 0.2°	26 kg
	1107 lbf.ft	9957 lbf.ft	7671 lbf.ft	29900 lbf	11915 lbf	7194 lbf	6295 lbf			57 lb
PEB7	1500 N.m	13500 N.m	10400 N.m	133 kN	53 kN	32 kN	28 kN	73 : 1	≤ 0.11°	26 kg
	1107 lbf.ft	9957 lbf.ft	7671 lbf.ft	29900 lbf	11915 lbf	7194 lbf	6295 lbf			57 lb



# Series SEB9/PEB9 Dimensions and Ratings

All dimensions in mm unless otherwise specified

## FRONT

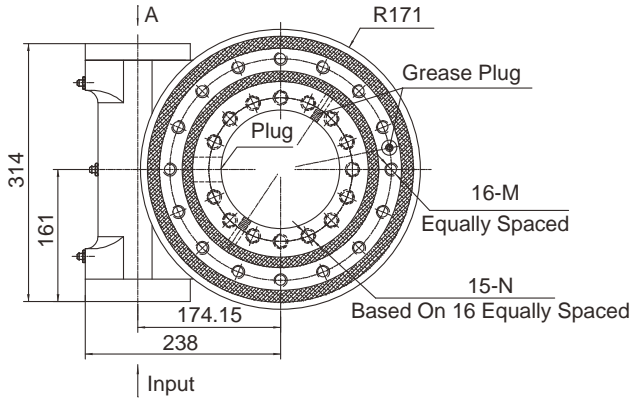

## INPUT

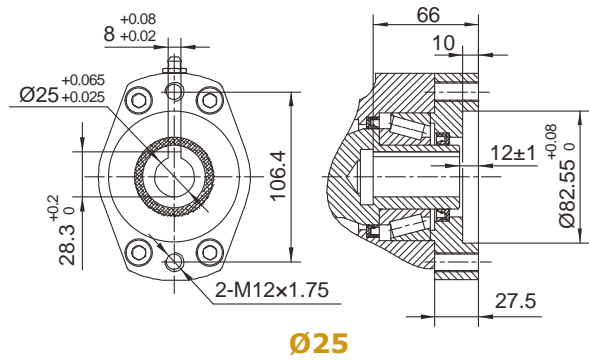

## SIDE

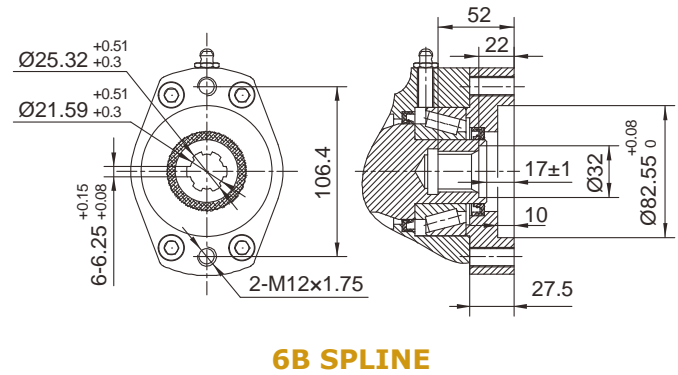
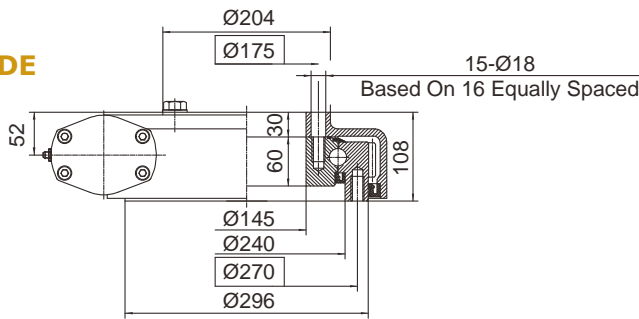

## MOMENT LOAD CHART

## MOUNTING HOLES OPTION

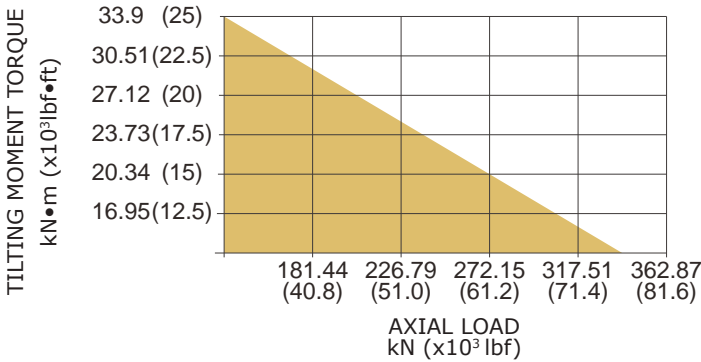

CODE 6&7	M (OUTER RING)	N (INNER RING)
--	M16×2 Tap 30	M16×2 Tap 30
-T	M16×2 Tap 30	Ø18 Thru
B-	5/8"-11UNC-2B Tap 30	5/8"-11UNC-2B Tap 30
BT	5/8"-11UNC-2B Tap 30	Ø18 Thru

## PERFORMANCE PARAMETERS

MODEL	OUTPUT TORQUE	TILTING MOMENT TORQUE	HOLDING TORQUE	STATIC AXIAL RATING	STATIC RADIAL RATING	DYNAMIC AXIAL RATING	DYNAMIC RADIAL RATING	GEAR RATIO	TRACKING PRECISION	WEIGHT
SEB9	6.5 kN.m	33.9 kN.m	34.5 kN.m	338 kN	135 kN	81 kN	71 kN	61 : 1	≤ 0.17°	49 kg
	4794 lbf.ft	25×10 <sup>3</sup> lbf.ft	25.5×10 <sup>3</sup> lbf.ft	76×10 <sup>3</sup> lbf	30×10 <sup>3</sup> lbf	18×10 <sup>3</sup> lbf	16×10 <sup>3</sup> lbf			108 lb
PEB9	6.5 kN.m	33.9 kN.m	34.5 kN.m	338 kN	135 kN	81 kN	71 kN	61 : 1	≤ 0.09°	49 kg
	4794 lbf.ft	25×10 <sup>3</sup> lbf.ft	25.5×10 <sup>3</sup> lbf.ft	76×10 <sup>3</sup> lbf	30×10 <sup>3</sup> lbf	18×10 <sup>3</sup> lbf	16×10 <sup>3</sup> lbf			108 lb

All dimensions in mm unless otherwise specified

## FRONT

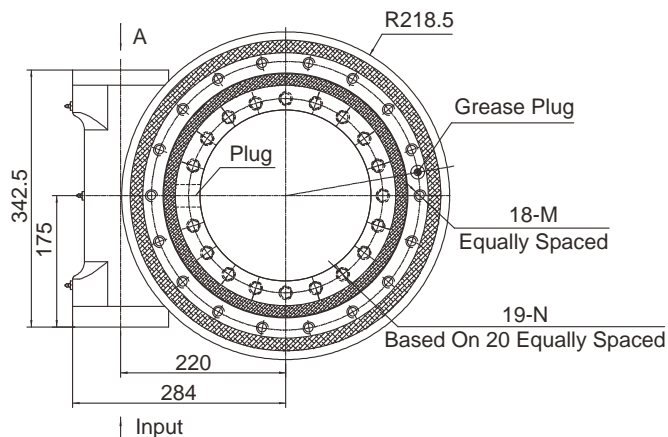

## INPUT

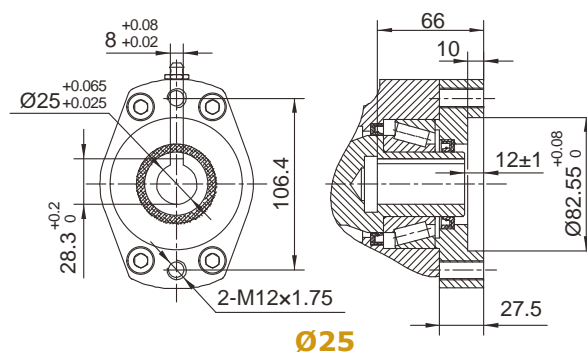

## SIDE

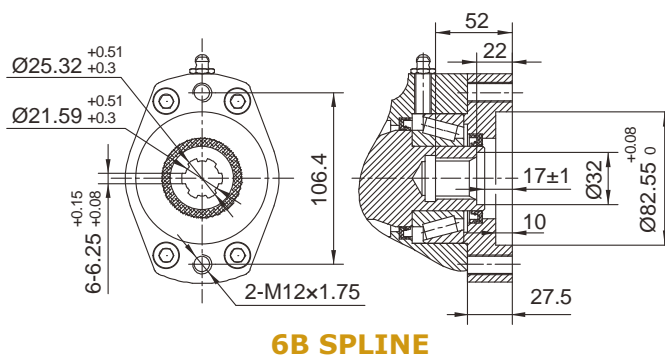
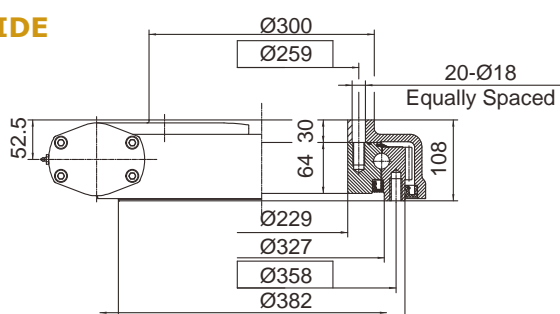

## MOMENT LOAD CHART

## MOUNTING HOLES OPTION

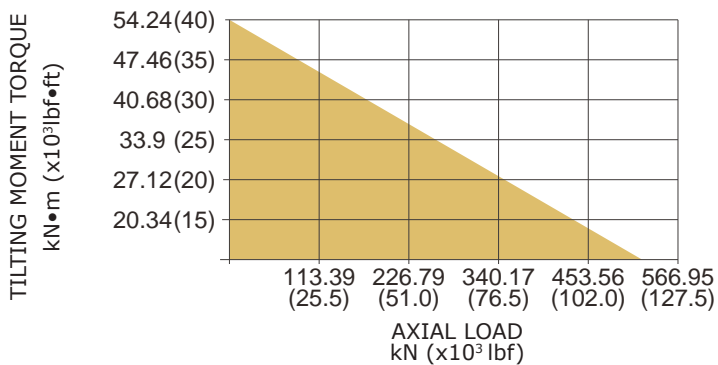

CODE 6&7	M (OUTER RING)	N (INNER RING)
- -	M16×2 Tap 30	M16×2 Tap 30
- T	M16×2 Tap 30	Ø18 Thru
B -	5/8"-11UNC-2B Tap 30	5/8"-11UNC-2B Tap30
B T	5/8"-11UNC-2B Tap 30	Ø18 Thru

## PERFORMANCE PARAMETERS

MODEL	OUTPUT TORQUE	TILTING MOMENT TORQUE	HOLDING TORQUE	STATIC AXIAL RATING	STATIC RADIAL RATING	DYNAMIC AXIAL RATING	DYNAMIC RADIAL RATING	GEAR RATIO	TRACKING PRECISION	WEIGHT
SEB12	7.5 kN.m	54.3 kN.m	43 kN.m	475 kN	190 kN	114 kN	100 kN	78 : 1	≤ 0.17°	68 kg
	5532 lbf.ft	40×10 <sup>3</sup> lbf.ft	32×10 <sup>3</sup> lbf.ft	107×10 <sup>3</sup> lbf	43×10 <sup>3</sup> lbf	26×10 <sup>3</sup> lbf	23×10 <sup>3</sup> lbf			150 lb
PEB12	7.5 kN.m	54.3 N.m	43 kN.m	475 kN	190 kN	114 kN	100 kN	78 : 1	≤ 0.07°	68 kg
	5532 lbf.ft	40×10 <sup>3</sup> lbf.ft	32×10 <sup>3</sup> lbf.ft	107×10 <sup>3</sup> lbf	43×10 <sup>3</sup> lbf	26×10 <sup>3</sup> lbf	23×10 <sup>3</sup> lbf			150 lb

# Series SEB14/PEB14 Dimensions and Ratings

All dimensions in mm unless otherwise specified

## FRONT

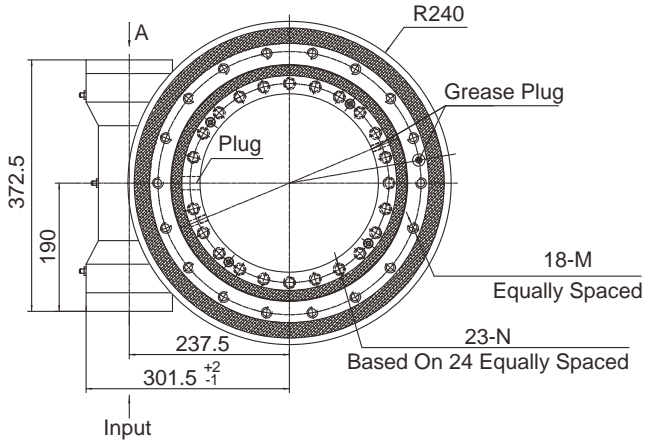

## INPUT

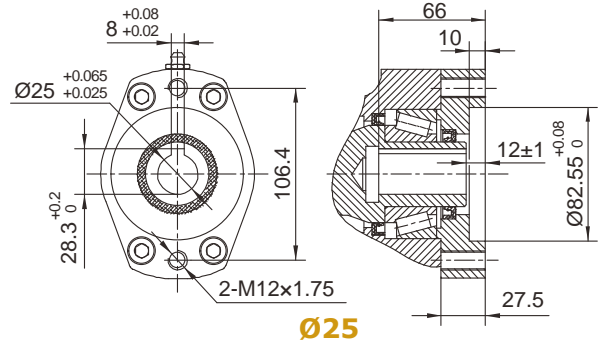

## SIDE

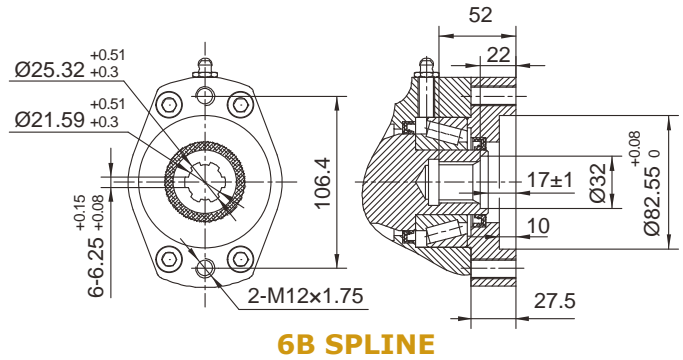
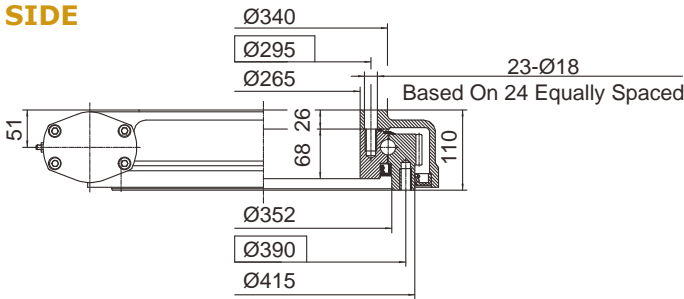

## MOMENT LOAD CHART

## MOUNTING HOLES OPTION

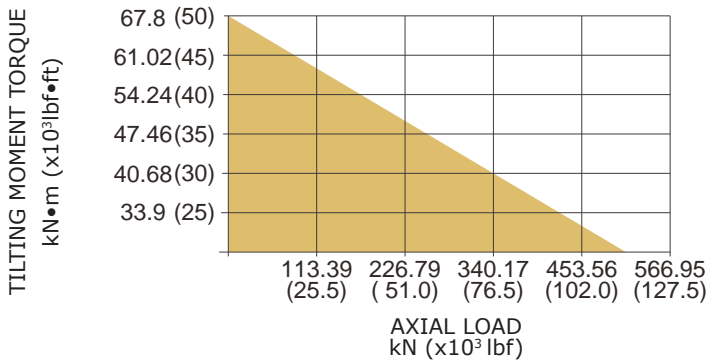

CODE 6&7	M (OUTER RING)	N (INNER RING)
- -	M16×2 Tap 30	M16×2 Tap 30
- T	M16×2 Tap 30	Ø18 Thru
B -	5/8"-11UNC-2B Tap 30	5/8"-11UNC-2B Tap 30
B T	5/8"-11UNC-2B Tap 30	Ø18 Thru

## PERFORMANCE PARAMETERS

MODEL	OUTPUT TORQUE	TILTING MOMENT TORQUE	HOLDING TORQUE	STATIC AXIAL RATING	STATIC RADIAL RATING	DYNAMIC AXIAL RATING	DYNAMIC RADIAL RATING	GEAR RATIO	TRACKING PRECISION	WEIGHT
SEB14	8 kN.m	67.8 kN.m	48 kN.m	555 kN	222 kN	133 kN	117 kN	85 : 1	≤ 0.17°	74 kg
	5900 lbf.ft	50×10 <sup>3</sup> lbf.ft	35×10 <sup>3</sup> lbf.ft	125×10 <sup>3</sup> lbf	50×10 <sup>3</sup> lbf	30×10 <sup>3</sup> lbf	26×10 <sup>3</sup> lbf			163 lb
PEB14	8 kN.m	67.8 kN.m	48 kN.m	555 kN	222 kN	133 kN	117 kN	85 : 1	≤ 0.09°	74 kg
	5900 lbf.ft	50×10 <sup>3</sup> lbf.ft	35×10 <sup>3</sup> lbf.ft	125×10 <sup>3</sup> lbf	50×10 <sup>3</sup> lbf	30×10 <sup>3</sup> lbf	26×10 <sup>3</sup> lbf			163 lb

All dimensions in mm unless otherwise specified

## FRONT

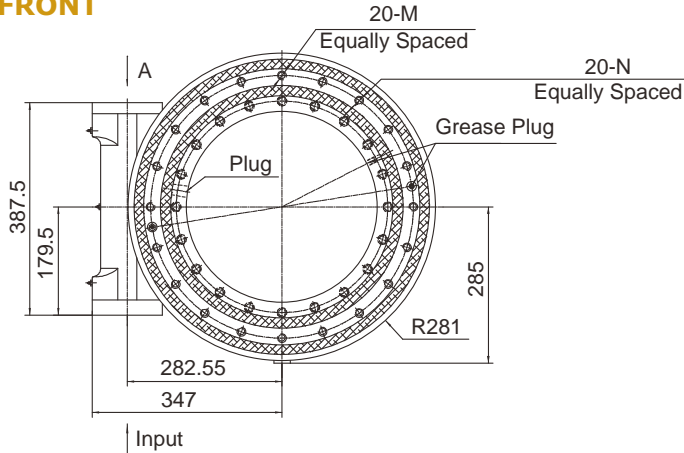

## INPUT

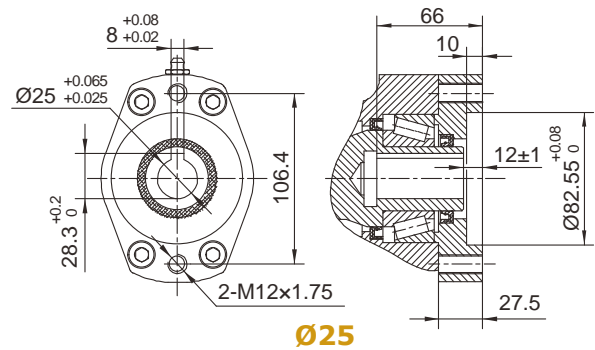

## SIDE

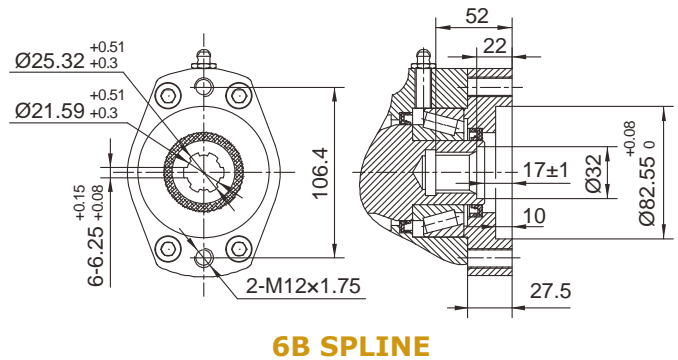
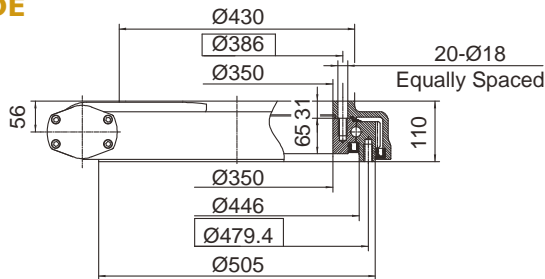

## MOMENT LOAD CHART

## MOUNTING HOLES OPTION

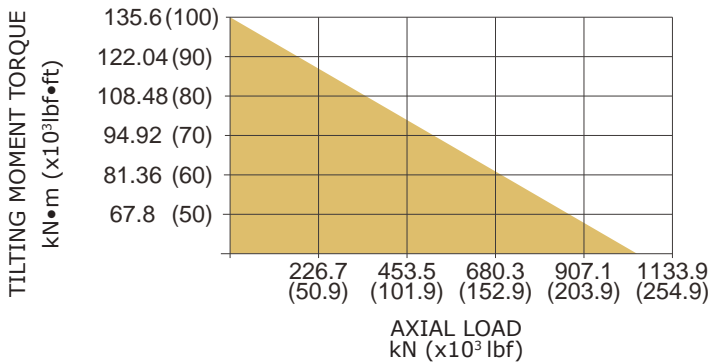

CODE 6&7	M (OUTER RING)	N (INNER RING)
- -	M16×2 Tap 32	M16×2 Tap 32
- T	M16×2 Tap 32	Ø18 Thru
B -	5/8"-11UNC-2B Tap 32	5/8"-11UNC-2B Tap 32
B T	5/8"-11UNC-2B Tap 32	Ø18 Thru

## PERFORMANCE PARAMETERS

MODEL	OUTPUT TORQUE	TILTING MOMENT TORQUE	HOLDING TORQUE	STATIC AXIAL RATING	STATIC RADIAL RATING	DYNAMIC AXIAL RATING	DYNAMIC RADIAL RATING	GEAR RATIO	TRACKING PRECISION	WEIGHT
SEB 17C	10 kN.m	135.6 kN.m	58 kN.m	970 kN	390 kN	235 kN	205 kN	102 : 1	≤ 0.15°	92 kg
	7400 lbf.ft	100×10³ lbf.ft	42.8×10³ lbf.ft	218×10³ lbf	88×10³ lbf	53×10³ lbf	46×10³ lbf			203 lb
PEB 17C	10 kN.m	135.6 kN.m	58 kN.m	970 kN	390 kN	235 kN	205 kN	102 : 1	≤ 0.09°	92 kg
	7400 lbf.ft	100×10³ lbf.ft	42.8×10³ lbf.ft	218×10³ lbf	88×10³ lbf	53×10³ lbf	46×10³ lbf			203 lb

# Series SEB21/PEB21 Dimensions and Ratings

All dimensions in mm unless otherwise specified

## FRONT

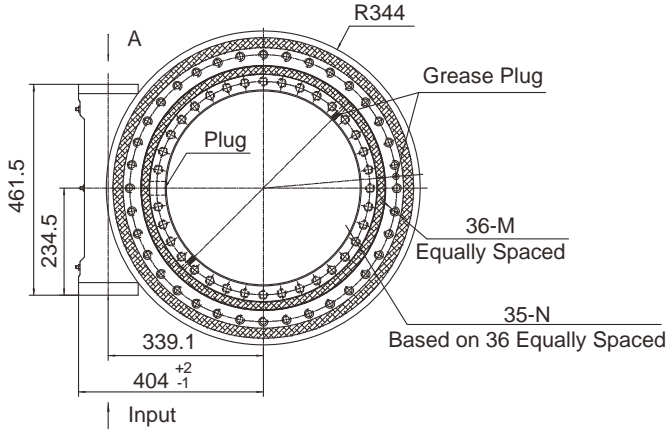

## INPUT

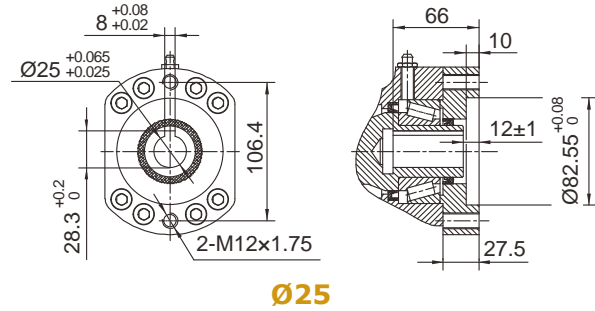

## SIDE

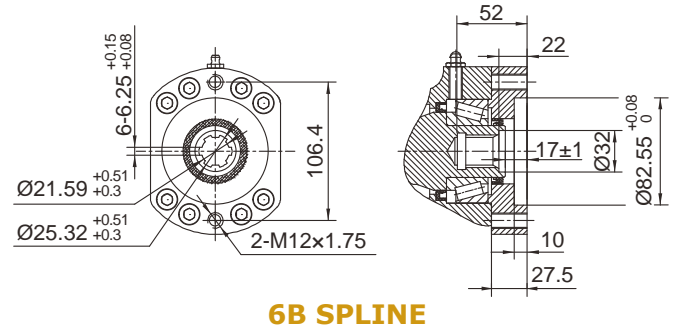
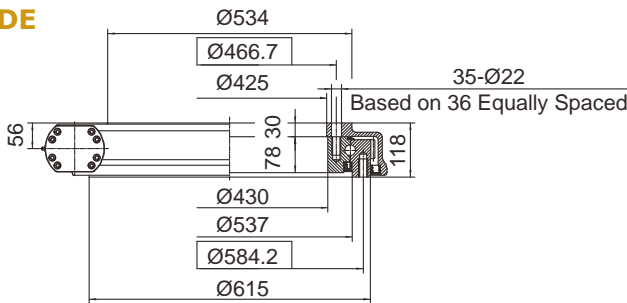

## MOMENT LOAD CHART

## MOUNTING HOLES OPTION

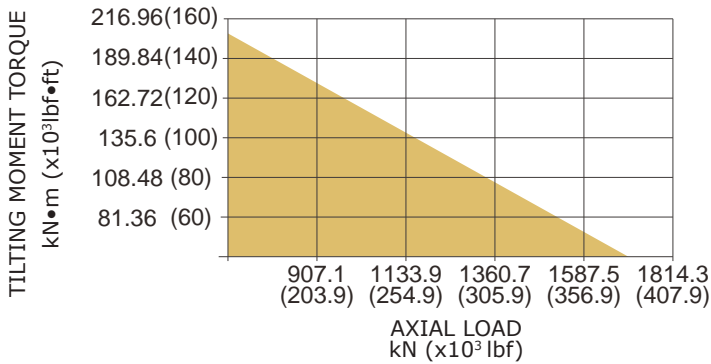

CODE	M (OUTER RING)	N (INNER RING)
6&7	M20×2.5 Tap 40	M20×2.5 Tap 40
- T	M20×2.5 Tap 40	Ø22 Thru
B -	3/4"-10UNC-2B Tap 40	3/4"-10UNC-2B Tap 40
B T	3/4"-10UNC-2B Tap 40	Ø22 Thru

## PERFORMANCE PARAMETERS

MODEL	OUTPUT TORQUE	TILTING MOMENT TORQUE	HOLDING TORQUE	STATIC AXIAL RATING	STATIC RADIAL RATING	DYNAMIC AXIAL RATING	DYNAMIC RADIAL RATING	GEAR RATIO	TRACKING PRECISION	WEIGHT
SEB21	15 kN.m	203 kN.m	70.5 kN.m	1598 kN	640 kN	385 kN	335 kN	125 : 1	≤ 0.15°	142 kg
	11000 lbf.ft	150×10 <sup>3</sup> lbf.ft	52×10 <sup>3</sup> lbf.ft	359×10 <sup>3</sup> lbf	144×10 <sup>3</sup> lbf	87×10 <sup>3</sup> lbf	75×10 <sup>3</sup> lbf			313 lb
PEB21	15 kN.m	203 kN.m	70.5 kN.m	1598 kN	640 kN	385 kN	335 kN	125 : 1	≤ 0.09°	142 kg
	11000 lbf.ft	150×10 <sup>3</sup> lbf.ft	52×10 <sup>3</sup> lbf.ft	359×10 <sup>3</sup> lbf	144×10 <sup>3</sup> lbf	87×10 <sup>3</sup> lbf	75×10 <sup>3</sup> lbf			313 lb

All dimensions in mm unless otherwise specified

## FRONT

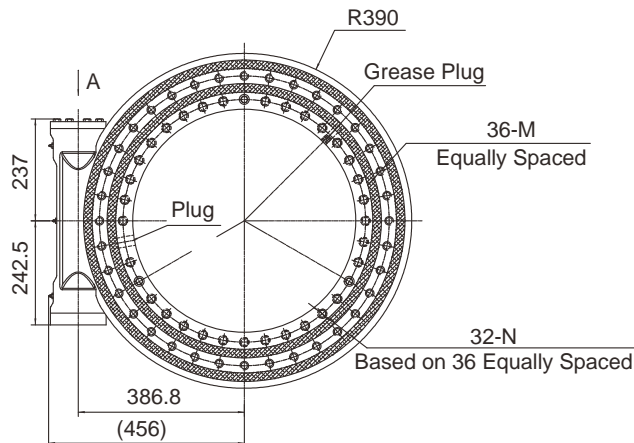

## INPUT

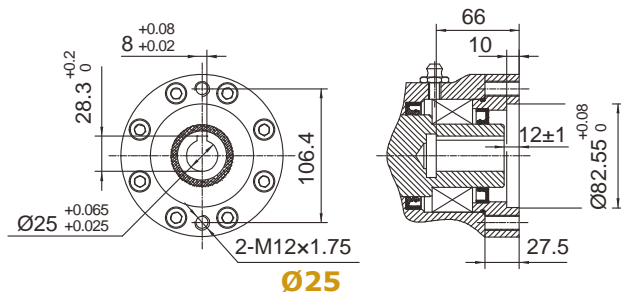

## SIDE

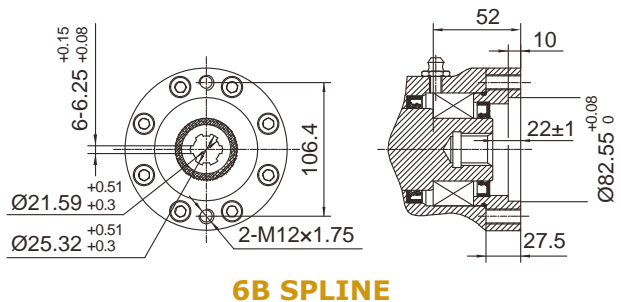
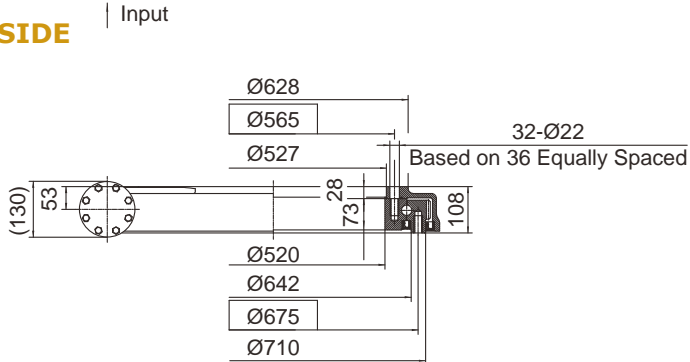

## MOMENT LOAD CHART

## MOUNTING HOLES OPTION

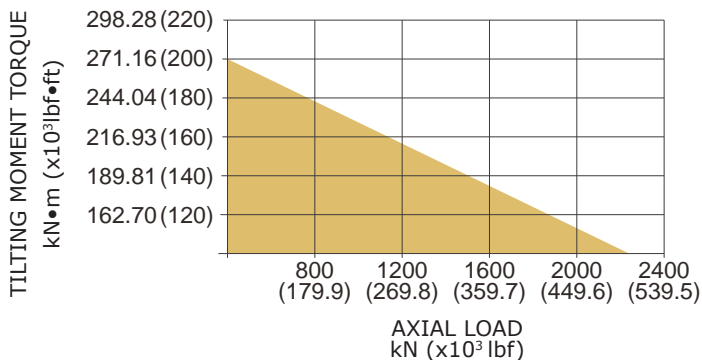

CODE 6&7	M (OUTER RING)	N (INNER RING)
- -	M20×2.5 Tap 40	M20×2.5 Tap 40
- T	M20×2.5 Tap 40	Ø22 Thru
B -	3/4"-10UNC-2B Tap 40	3/4"-10UNC-2B Tap 40
B T	3/4"-10UNC-2B Tap 40	Ø22 Thru

## PERFORMANCE PARAMETERS

MODEL	OUTPUT TORQUE	TILTING MOMENT TORQUE	HOLDING TORQUE	STATIC AXIAL RATING	STATIC RADIAL RATING	DYNAMIC AXIAL RATING	DYNAMIC RADIAL RATING	GEAR RATIO	TRACKING PRECISION	WEIGHT
SEB25	18 kN.m	271 kN.m	84.5 kN.m	2360 kN	945 kN	590 kN	470 kN	150 : 1	≤ 0.15°	168 kg
	13300 lbf.ft	200×10 <sup>3</sup> lbf.ft	62.4×10 <sup>3</sup> lbf.ft	531×10 <sup>3</sup> lbf	212×10 <sup>3</sup> lbf	133×10 <sup>3</sup> lbf	106×10 <sup>3</sup> lbf			370 lb
PEB25	18 kN.m	271 kN.m	84.5 kN.m	2360 kN	945 kN	590 kN	470 kN	150 : 1	≤ 0.09°	168 kg
	13300 lbf.ft	200×10 <sup>3</sup> lbf.ft	117×10 <sup>3</sup> lbf.ft	531×10 <sup>3</sup> lbf	212×10 <sup>3</sup> lbf	133×10 <sup>3</sup> lbf	106×10 <sup>3</sup> lbf			370 lb



All dimensions in mm unless otherwise specified

## FRONT

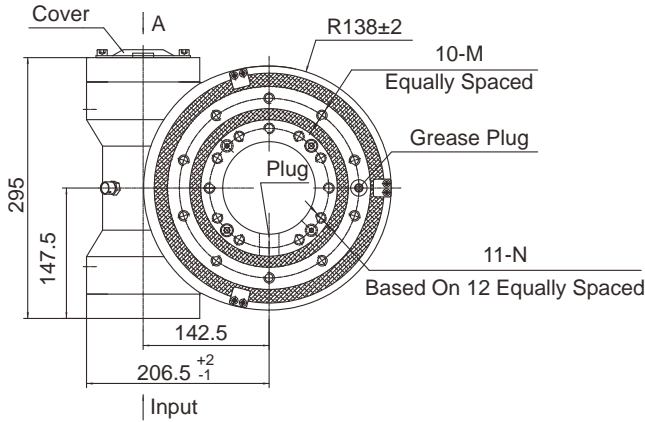

## INPUT

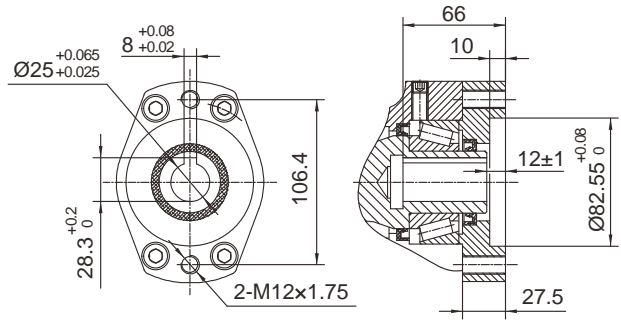

Ø25

## SIDE

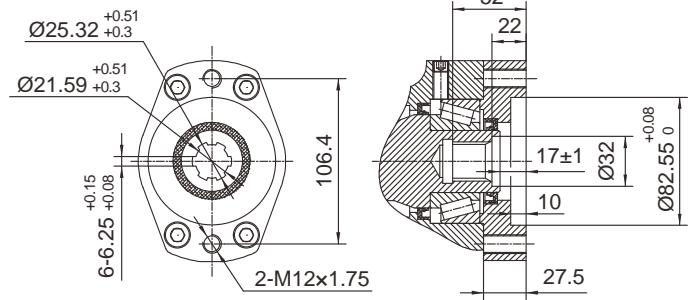
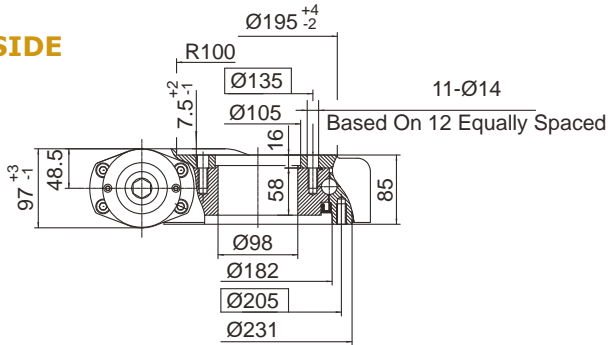

6B SPLINE

## MOMENT LOAD CHART

## MOUNTING HOLES OPTION

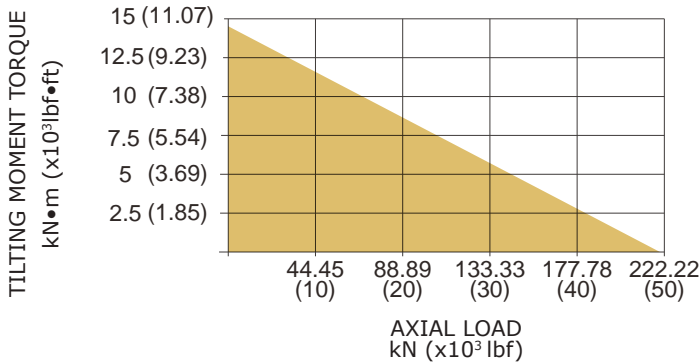

CODE 6&7	M (OUTER RING)	N (INNER RING)
--	M12×1.75 Tap 25	M12×1.75 Tap 25
- T	M12×1.75 Tap 25	Ø14 Thru
B -	1/2"-13UNC-2B Tap 25	1/2"-13UNC-2B Tap 25
B T	1/2"-13UNC-2B Tap 25	Ø14 Thru

## PERFORMANCE PARAMETERS

OUTPUT TORQUE	TILTING MOMENT TORQUE	HOLDING TORQUE	STATIC AXIAL RATING	STATIC RADIAL RATING	DYNAMIC AXIAL RATING	DYNAMIC RADIAL RATING	GEAR RATIO	TRACKING PRECISION	WEIGHT
3.5 kN.m	14.2 kN.m	20 kN.m	220 kN	90 kN	63 kN	48 kN	47 : 1	≤ 0.15°	37.5 kg
2583 lbf.ft	10.5×10 <sup>3</sup> lbf.ft	14.8×10 <sup>3</sup> lbf.ft	49.5×10 <sup>3</sup> lbf	20.2×10 <sup>3</sup> lbf	14.2×10 <sup>3</sup> lbf	10.8×10 <sup>3</sup> lbf			83 lb



All dimensions in mm unless otherwise specified

## FRONT

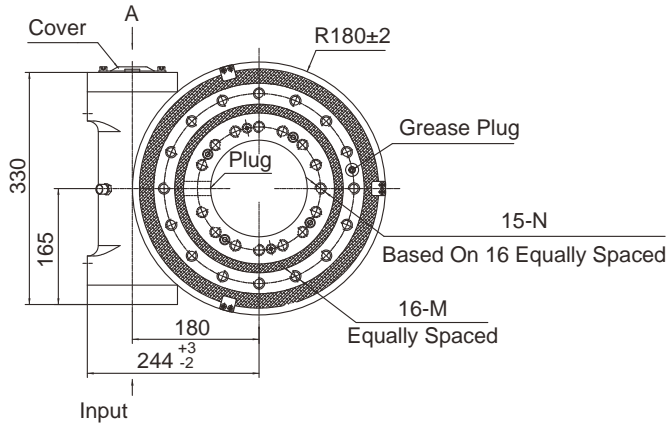

## SIDE

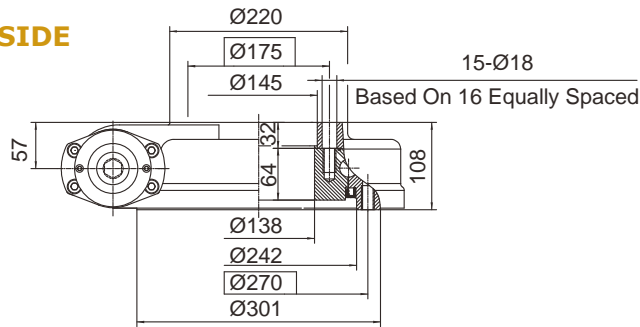

## INPUT

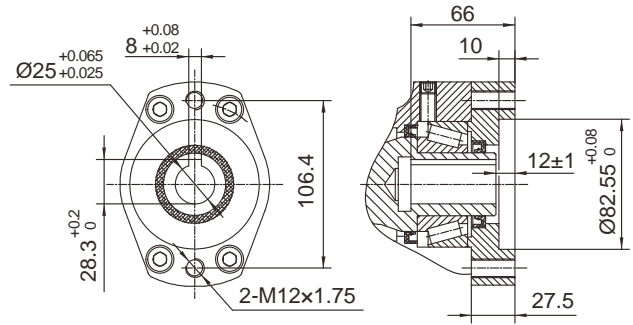

**Ø25**

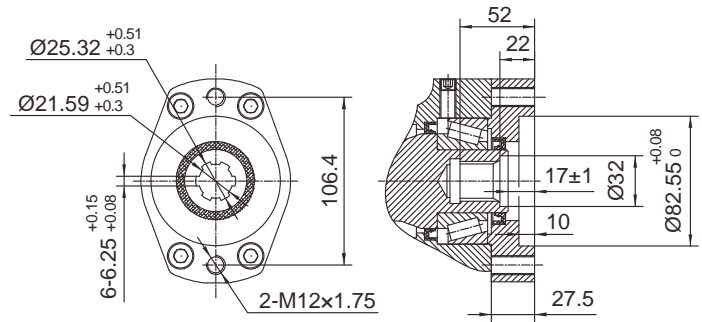

**6B SPLINE**

## MOMENT LOAD CHART

## MOUNTING HOLES OPTION

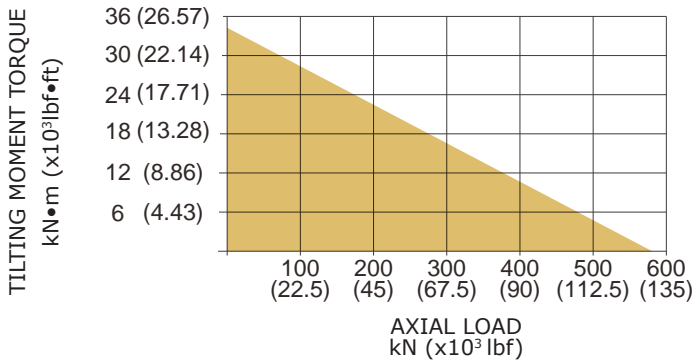

CODE	M (OUTER RING)	N (INNER RING)
6&7	M16×2 Tap 30	N16×2 Tap 30
- -	M16×2 Tap 30	M16×2 Tap 30
- T	M16×2 Tap 30	Ø18 Thru
B -	5/8"-11UNC-2B Tap 30	5/8"-11UNC-2B Tap 30
B T	5/8"-11UNC-2B Tap 30	Ø18 Thru

## PERFORMANCE PARAMETERS

OUTPUT TORQUE	TILTING MOMENT TORQUE	HOLDING TORQUE	STATIC AXIAL RATING	STATIC RADIAL RATING	DYNAMIC AXIAL RATING	DYNAMIC RADIAL RATING	GEAR RATIO	TRACKING PRECISION	WEIGHT
8 kN.m	35.6 kN.m	34.5 kN.m	578 kN	215 kN	136 kN	115 kN	62 : 1	≤ 0.15°	55.5 kg
5904 lbf.ft	26.3×10³ lbf.ft	25.5×10³ lbf.ft	129.9×10³ lbf	48.3×10³ lbf	30.6×10³ lbf	25.9×10³ lbf			122 lb

# Series HSE12 Dimensions and Ratings

All dimensions in mm unless otherwise specified

## FRONT

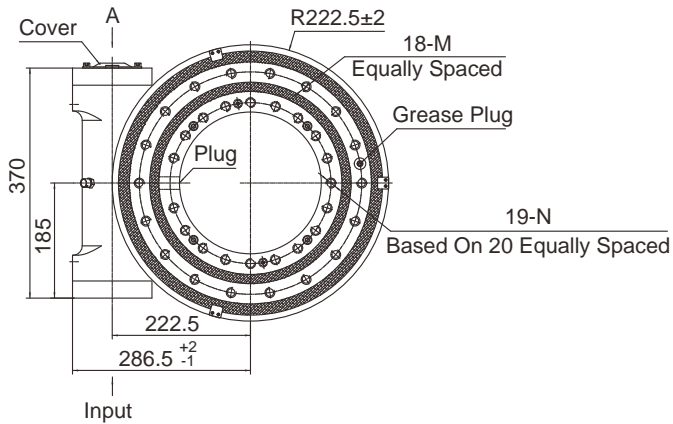

## SIDE

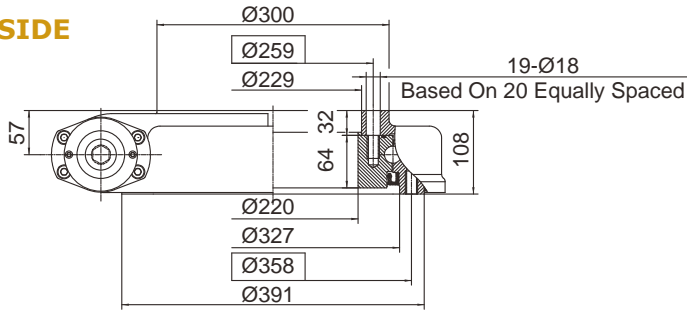

## INPUT

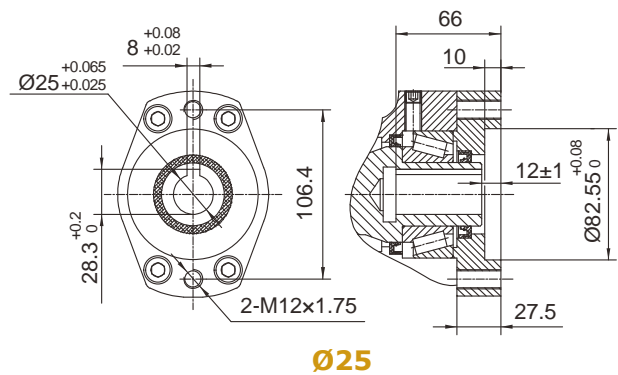

Ø25

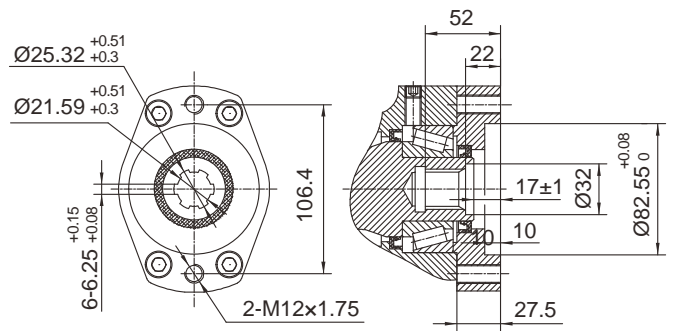

6B SPLINE

## MOMENT LOAD CHART

## MOUNTING HOLES OPTION

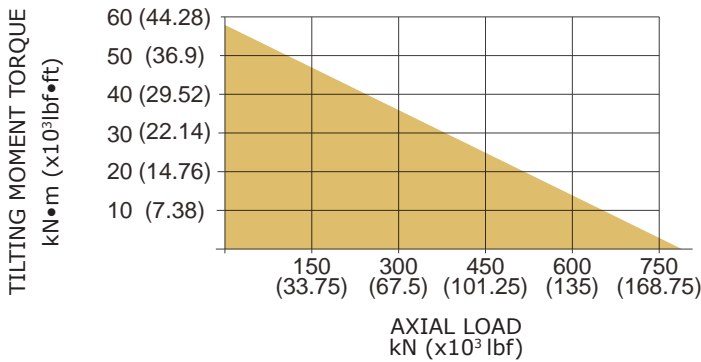

CODE	M (OUTER RING)	N (INNER RING)
6&7	M16×2 Tap 30	M16×2 Tap 30
- T	M16×2 Tap 30	Ø18 Thru
B -	5/8"-11UNC-2B Tap 30	5/8"-11UNC-2B Tap 30
B T	5/8"-11UNC-2B Tap 30	Ø18 Thru

## PERFORMANCE PARAMETERS

OUTPUT TORQUE	TILTING MOMENT TORQUE	HOLDING TORQUE	STATIC AXIAL RATING	STATIC RADIAL RATING	DYNAMIC AXIAL RATING	DYNAMIC RADIAL RATING	GEAR RATIO	TRACKING PRECISION	WEIGHT
9.5 kN.m	57 kN.m	43 kN.m	760 kN	280 kN	190 kN	148 kN	79 : 1	≤ 0.15°	74 kg
7011 lbf.ft	42.1×10³ lbf.ft	32×10³ lbf.ft	171.1×10³ lbf	62.9×10³ lbf	42.7×10³ lbf	33.3×10³ lbf			163 lb

All dimensions in mm unless otherwise specified

## FRONT

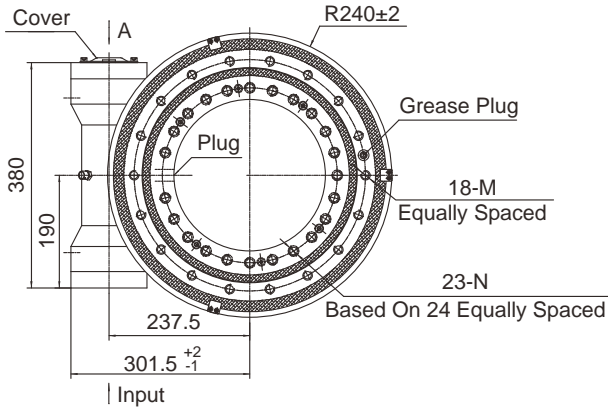

## SIDE

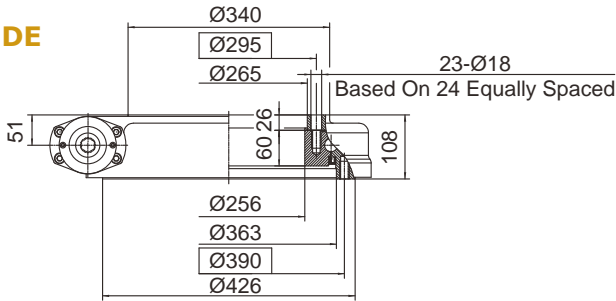

## INPUT

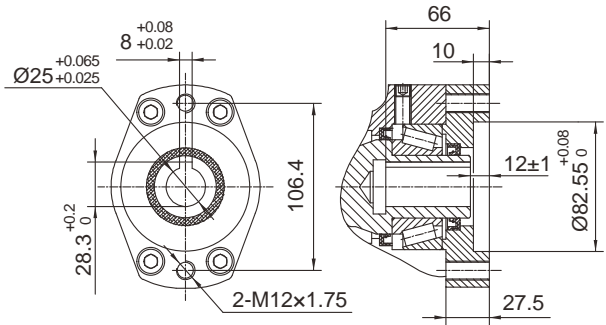

**Ø25**

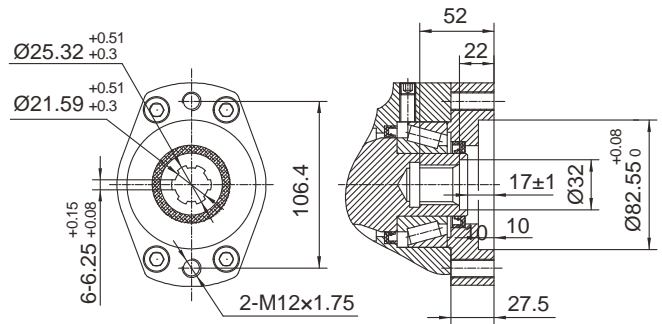

**6B SPLINE**

## MOMENT LOAD CHART

## MOUNTING HOLES OPTION

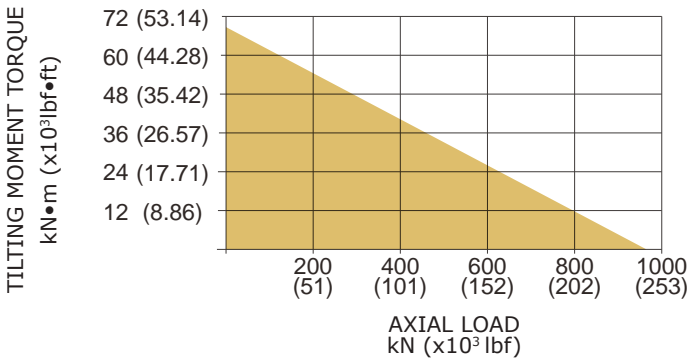

CODE 6&7	M (OUTER RING)	N (INNER RING)
- -	M16×2 Tap 30	M16×2 Tap 30
- T	M16×2 Tap 30	Ø18 Thru
B -	5/8"-11UNC-2B Tap 30	5/8"-11UNC-2B Tap 30
B T	5/8"-11UNC-2B Tap 30	Ø18 Thru

## PERFORMANCE PARAMETERS

OUTPUT TORQUE	TILTING MOMENT TORQUE	HOLDING TORQUE	STATIC AXIAL RATING	STATIC RADIAL RATING	DYNAMIC AXIAL RATING	DYNAMIC RADIAL RATING	GEAR RATIO	TRACKING PRECISION	WEIGHT
10.8kN.m	71.2 kN.m	48 kN.m	960 kN	360 kN	230 kN	200 kN	86 : 1	≤ 0.13°	82 kg
7970 lbf.ft	52.6×10³ lbf.ft	35×10³ lbf.ft	215.8×10³ lbf	80.9×10³ lbf	51.7×10³ lbf	44.9×10³ lbf			181 lb

# Series HSE17 Dimensions and Ratings

All dimensions in mm unless otherwise specified

## FRONT

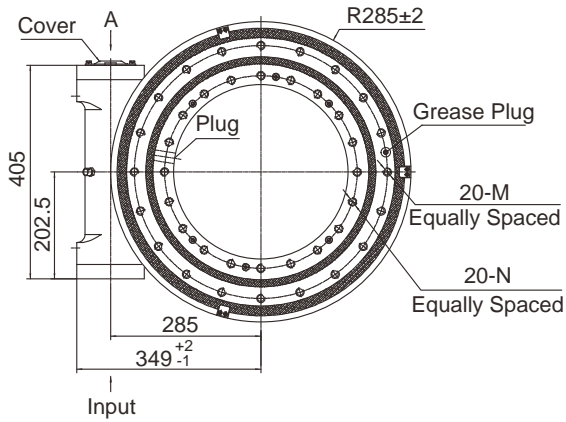

## INPUT

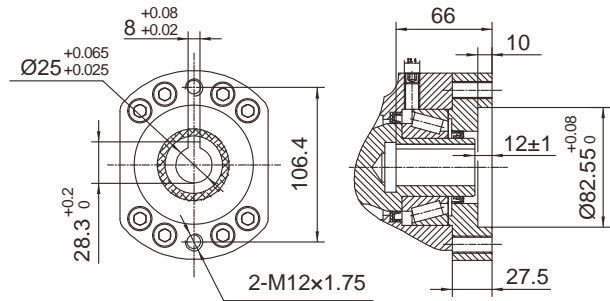

Ø25

## SIDE

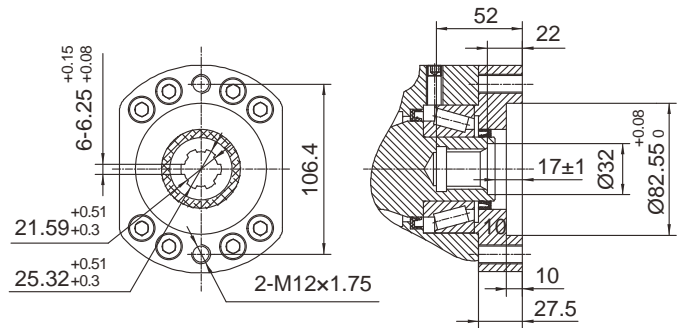
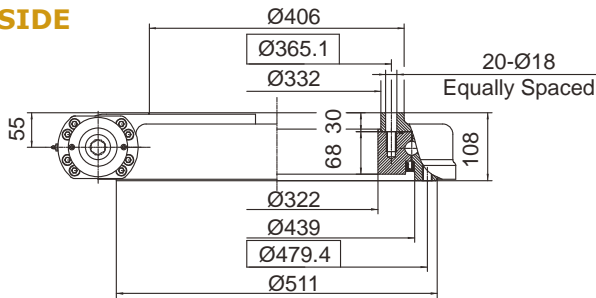

6B SPLINE

## MOMENT LOAD CHART

## MOUNTING HOLES OPTION

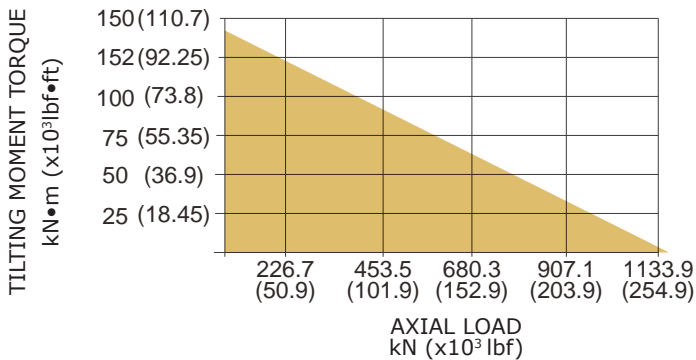

CODE	M (OUTER RING)	N (INNER RING)
6&7	M16×2 Tap 32	M16×2 Tap 32
- T	M16×2 Tap 32	Ø18 Thru
B -	5/8"-11UNC-2B Tap 32	5/8"-11UNC-2B Tap 32
B T	5/8"-11UNC-2B Tap 32	Ø18 Thru

## PERFORMANCE PARAMETERS

OUTPUT TORQUE	TILTING MOMENT TORQUE	HOLDING TORQUE	STATIC AXIAL RATING	STATIC RADIAL RATING	DYNAMIC AXIAL RATING	DYNAMIC RADIAL RATING	GEAR RATIO	TRACKING PRECISION	WEIGHT
12.96 kN.m	142.4 kN.m	72.3 kN.m	1166 kN	435 kN	280 kN	231 kN	104 : 1	≤ 0.1°	108 kg
9564 lbf.ft	105.1×10³ lbf.ft	53.4×10³ lbf.ft	262×10³ lbf	97.8×10³ lbf	62.9×10³ lbf	51.9×10³ lbf			238 lb

All dimensions in mm unless otherwise specified

## FRONT

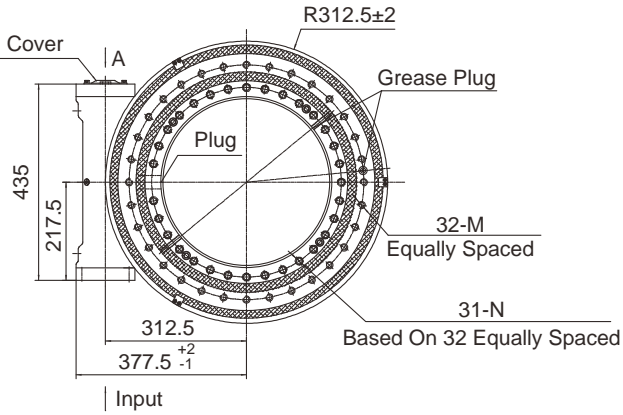

## INPUT

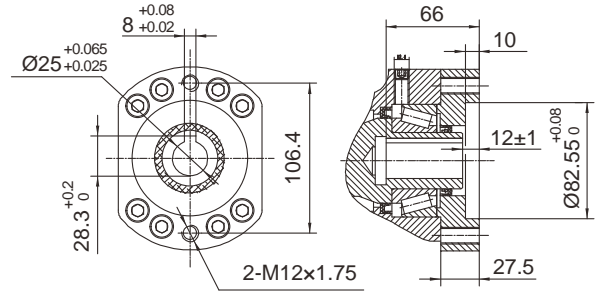

## SIDE

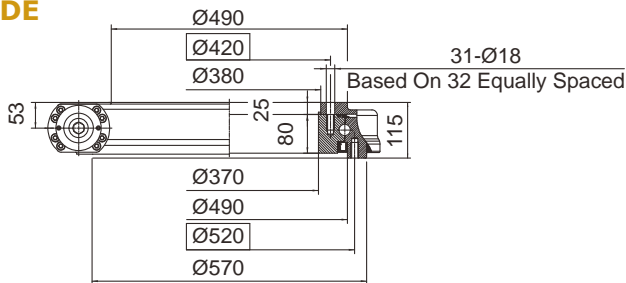

## Ø25

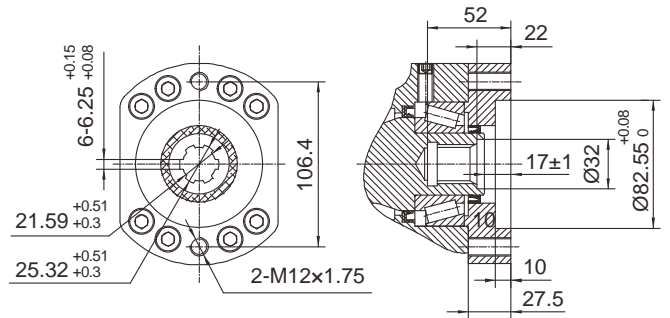

## 6B SPLINE

## MOMENT LOAD CHART

## MOUNTING HOLES OPTION

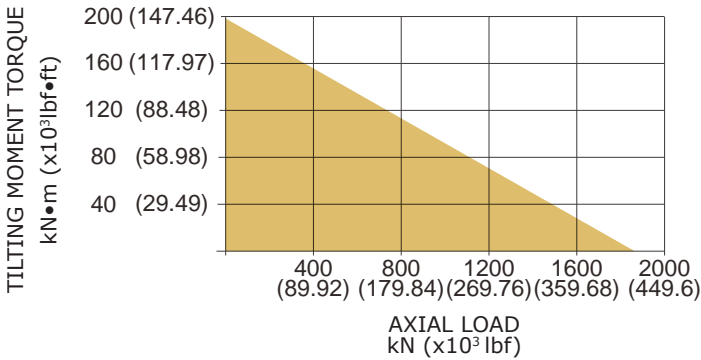

CODE 6&7	M (OUTER RING)	N (INNER RING)
--	M16×2 Tap 32	M16×2 Tap 32
- T	M16×2 Tap 32	Ø18 Thru
B -	5/8"-11UNC-2B Tap 32	5/8"-11UNC-2B Tap 32
B T	5/8"-11UNC-2B Tap 32	Ø18 Thru

## PERFORMANCE PARAMETERS

OUTPUT TORQUE	TILTING MOMENT TORQUE	HOLDING TORQUE	STATIC AXIAL RATING	STATIC RADIAL RATING	DYNAMIC AXIAL RATING	DYNAMIC RADIAL RATING	GEAR RATIO	TRACKING PRECISION	WEIGHT
18.5 kN.m	196 kN.m	80.1 kN.m	1800 kN	675 kN	290 kN	250 kN	94: 1	≤ 0.1°	122 kg
13640 lbf.ft	144.5×10³ lbf.ft	59.1×10³ lbf.ft	404.64×10³ lbf	151.4×10³ lbf	65.2×10³ lbf	56.2×10³ lbf			269 lb

# Series HSE21A Dimensions and Ratings

All dimensions in mm unless otherwise specified

## FRONT

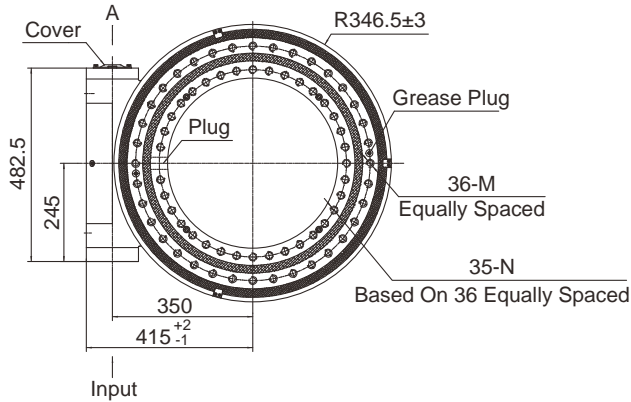

## INPUT

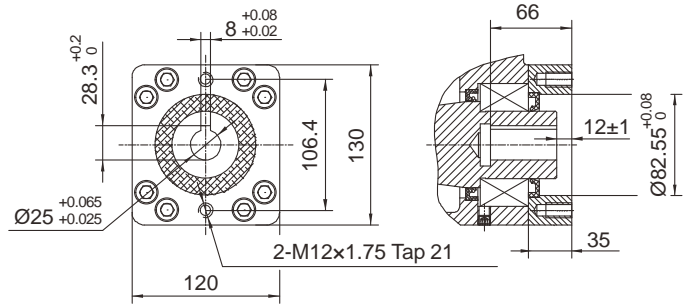

## SIDE

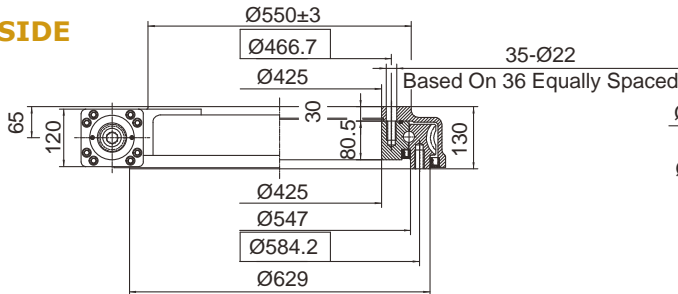

## Ø25

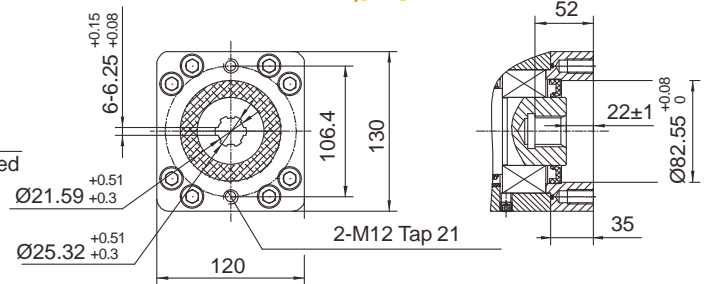

## 6B SPLINE

## MOMENT LOAD CHART

## MOUNTING HOLES OPTION

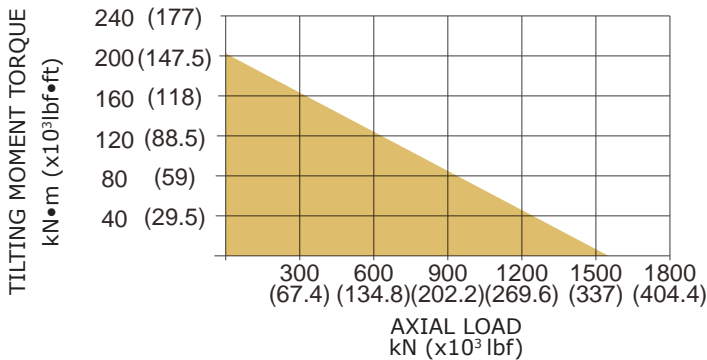

CODE	M (OUTER RING)	N (INNER RING)
6&7	M20×2.5 Tap 40	M20×2.5 Tap 40
- T	M20×2.5 Tap 40	Ø22 Thru
B -	3/4"-10UNC-2B Tap 40	3/4"-10UNC-2B Tap 40
B T	3/4"-10UNC-2B Tap 40	Ø22 Thru

## PERFORMANCE PARAMETERS

OUTPUT TORQUE	TILTING MOMENT TORQUE	HOLDING TORQUE	STATIC AXIAL RATING	STATIC RADIAL RATING	DYNAMIC AXIAL RATING	DYNAMIC RADIAL RATING	GEAR RATIO	TRACKING PRECISION	WEIGHT
28.7 kN.m	203 kN.m	105.8 kN.m	1598 kN	640 kN	385 kN	335 kN	90 : 1	≤ 0.1°	188 kg
21180 lbf.ft	150×10 <sup>3</sup> lbf.ft	78.1×10 <sup>3</sup> lbf.ft	359×10 <sup>3</sup> lbf	144×10 <sup>3</sup> lbf	87×10 <sup>3</sup> lbf	75×10 <sup>3</sup> lbf			414 lb

All dimensions in mm unless otherwise specified

## FRONT

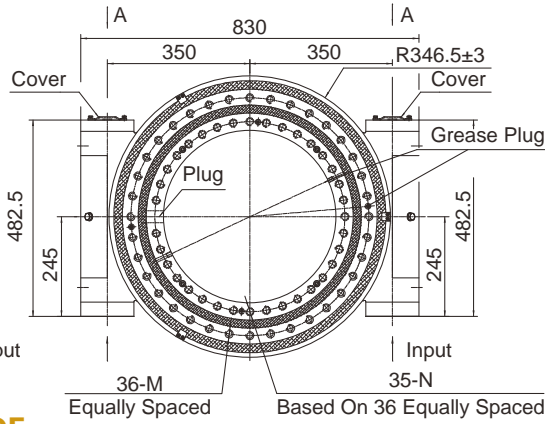

## SIDE

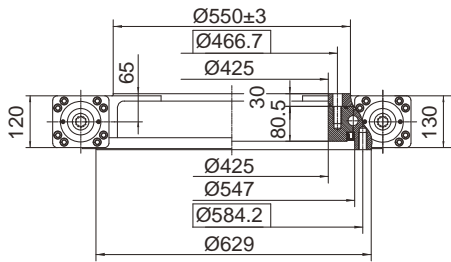

## INPUT

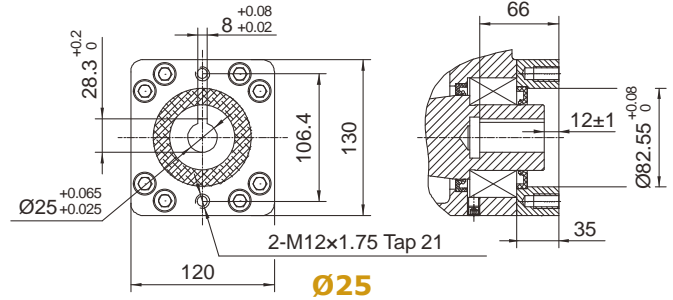

**Ø25**

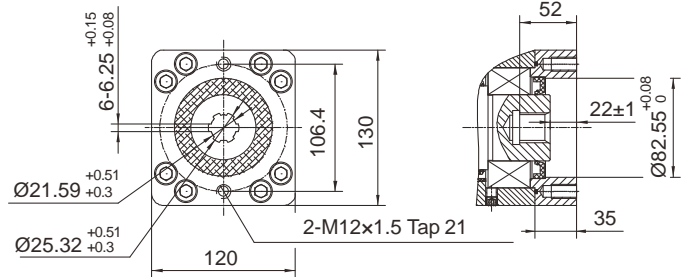

**6B SPLINE**

## MOMENT LOAD CHART

## MOUNTING HOLES OPTION

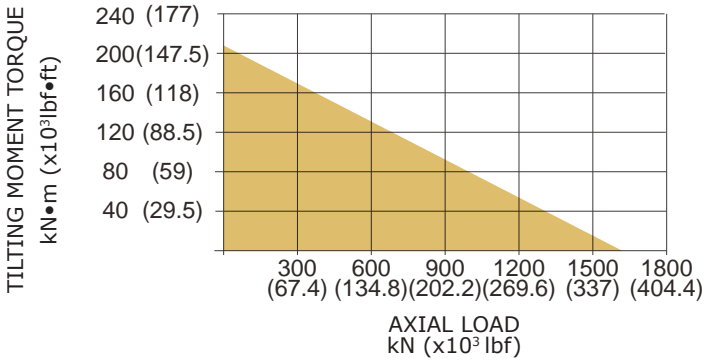

CODE 6&7	M (OUTER RING)	N (INNER RING)
- -	M20×2.5 Tap 40	M20×2.5 Tap 40
- T	M20×2.5 Tap 40	Ø22 Thru
B -	3/4"-10UNC-2B Tap 40	3/4"-10UNC-2B Tap 40
B T	3/4"-10UNC-2B Tap 40	Ø22 Thru

## PERFORMANCE PARAMETERS

OUTPUT TORQUE	TILTING MOMENT TORQUE	HOLDING TORQUE	STATIC AXIAL RATING	STATIC RADIAL RATING	DYNAMIC AXIAL RATING	DYNAMIC RADIAL RATING	GEAR RATIO	TRACKING PRECISION	WEIGHT
48 kN.m	203 kN.m	179.9 kN.m	1598 kN	640 kN	385 kN	335 kN	90: 1	≤ 0.1°	205 kg
35408 lbf.ft	150×10 <sup>3</sup> lbf.ft	132.7×10 <sup>3</sup> lbf.ft	359×10 <sup>3</sup> lbf	144×10 <sup>3</sup> lbf	87×10 <sup>3</sup> lbf	75×10 <sup>3</sup> lbf			452 lb



# Series HSE25 Dimensions and Ratings

All dimensions in mm unless otherwise specified

## FRONT

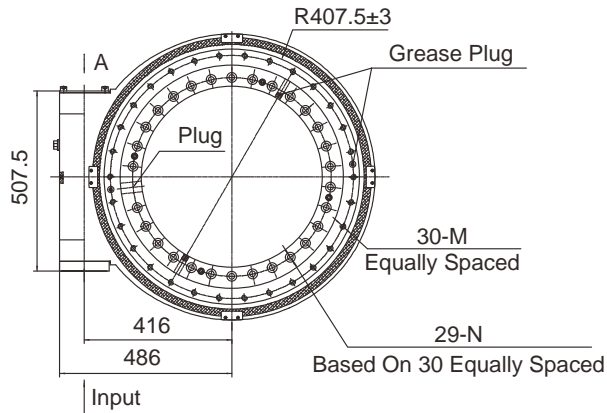

## INPUT

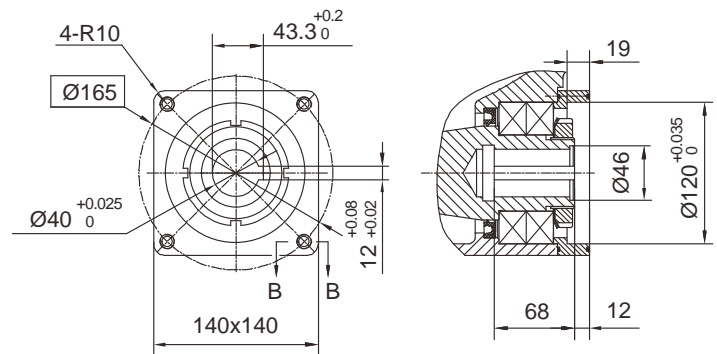

## SIDE

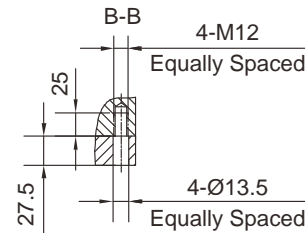
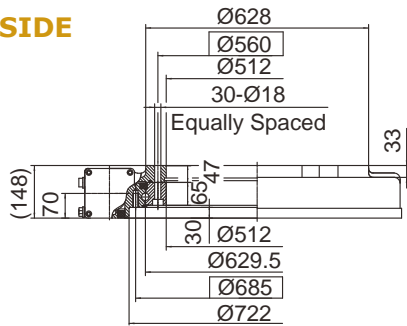

Ø40

## MOMENT LOAD CHART

## MOUNTING HOLES OPTION

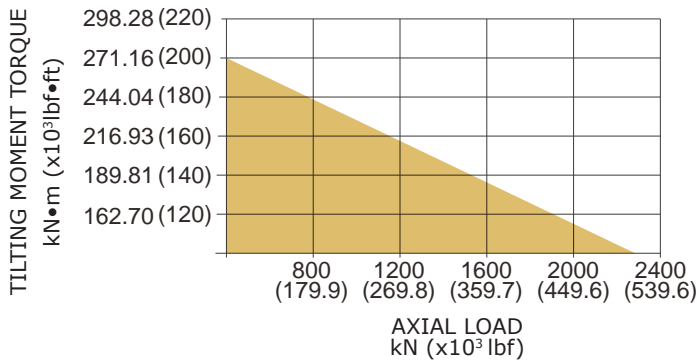

CODE	M (OUTER RING)	N (INNER RING)
6&7		
- -	M16×2 Tap 40	Ø18 Thru □ Ø30 T 17
- T	M16×2 Tap 40	Ø18 Thru □ Ø30 T 17
B -	5/8"-11UNC-2B Tap 40	Ø18 Thru □ Ø30 T 17
B T	5/8"-11UNC-2B Tap 40	Ø18 Thru □ Ø30 T 17

## PERFORMANCE PARAMETERS

OUTPUT TORQUE	TILTING MOMENT TORQUE	HOLDING TORQUE	STATIC AXIAL RATING	STATIC RADIAL RATING	DYNAMIC AXIAL RATING	DYNAMIC RADIAL RATING	GEAR RATIO	TRACKING PRECISION	WEIGHT
25 kN.m	30 kN.m	180 kN.m	2360 kN	945 kN	590 kN	470 kN	94 : 1	≤ 0.15°	255 kg
18439 lbf.ft	22140 lbf.ft	132.8×10³ lbf.ft	531×10³ lbf	212×10³ lbf	133×10³ lbf	106×10³ lbf			562 lb

All dimensions in mm unless otherwise specified

## FRONT

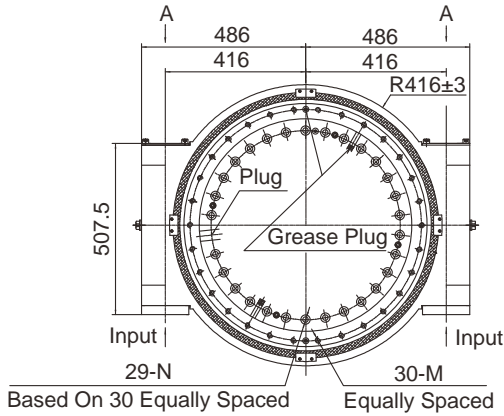

## INPUT

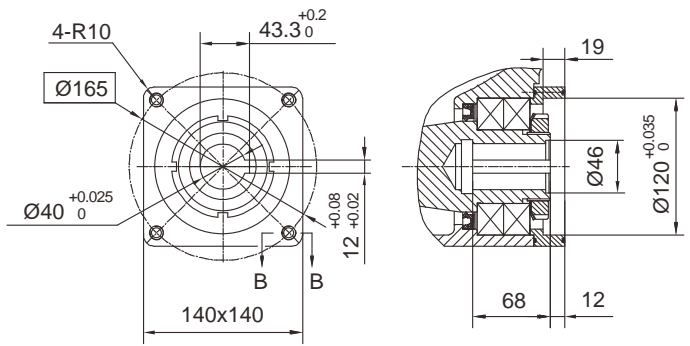

## SIDE

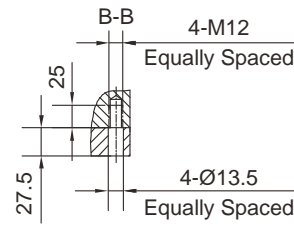
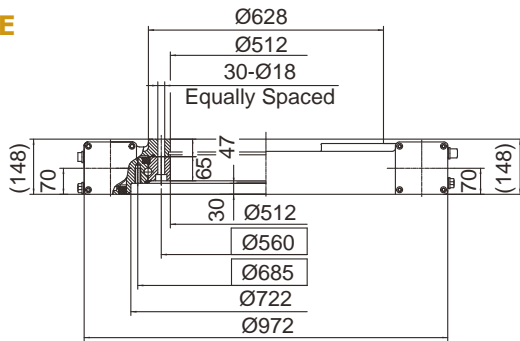

**Ø40**

## MOMENT LOAD CHART

## MOUNTING HOLES OPTION

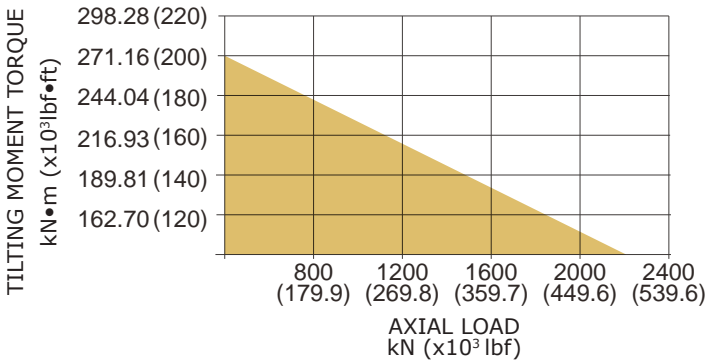

CODE 6&7	M (OUTER RING)	N (INNER RING)
- -	M16×2 Tap 40	Ø18 Thru □ Ø30 T 17
- T	M16×2 Tap 40	Ø18 Thru □ Ø30 T 17
B -	5/8"-11UNC-2B Tap 40	Ø18 Thru □ Ø30 T 17
B T	5/8"-11UNC-2B Tap 40	Ø18 Thru □ Ø30 T 17

## PERFORMANCE PARAMETERS

OUTPUT TORQUE	TILTING MOMENT TORQUE	HOLDING TORQUE	STATIC AXIAL RATING	STATIC RADIAL RATING	DYNAMIC AXIAL RATING	DYNAMIC RADIAL RATING	GEAR RATIO	TRACKING PRECISION	WEIGHT
50 kN.m	60 kN.m	180 kN.m	2360 kN	945 kN	590 kN	470 kN	94: 1	≤ 0.15°	275 kg
36878 lbf.ft	44280 lbf.ft	132.8×10 <sup>3</sup> lbf.ft	531×10 <sup>3</sup> lbf	212×10 <sup>3</sup> lbf	133×10 <sup>3</sup> lbf	106×10 <sup>3</sup> lbf			606 lb

All dimensions in mm unless otherwise specified

## FRONT

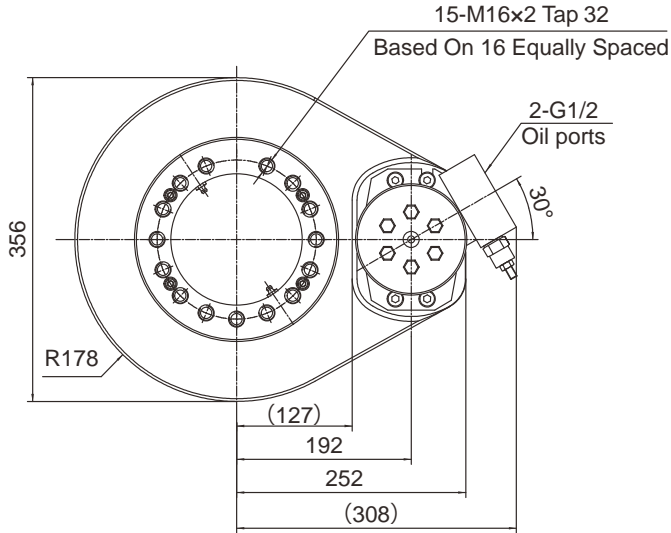

## SPUR GEAR DRIVE PERFORMANCE PARAMETERS

Module	4
Gear Ratio	5.33 : 1
Static Radial Rating	135 kN
Static Axial Rating	338 kN
Dynamic Radial Rating	71 kN
Dynamic Axial Rating	81 kN
Rated Torque	3216 kN
Rated Speed	5.06 rpm

## HYDRAULIC MOTOR PERFORMANCE PARAMETERS

Motor Displacement	625 ml/r
Flow	20 l/min
Pressure	8.5 MPa
Torque	710 Nm
Speed	27 rpm

## SIDE

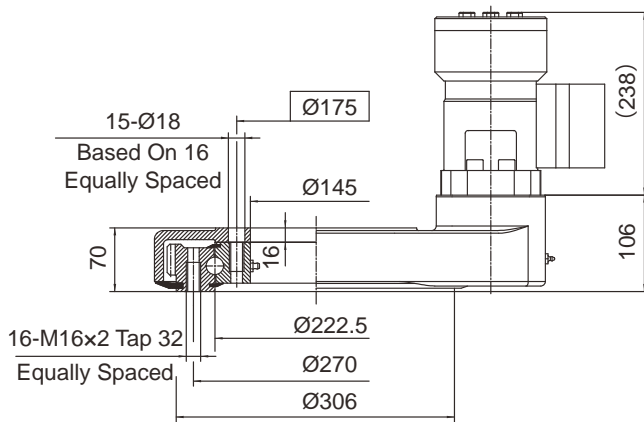

## MOMENT LOAD CHART

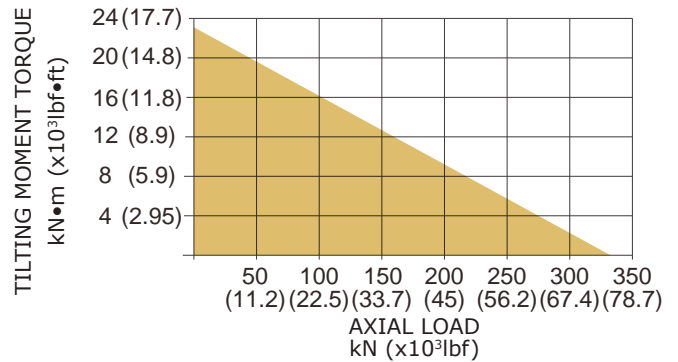

All dimensions in mm unless otherwise specified

## FRONT

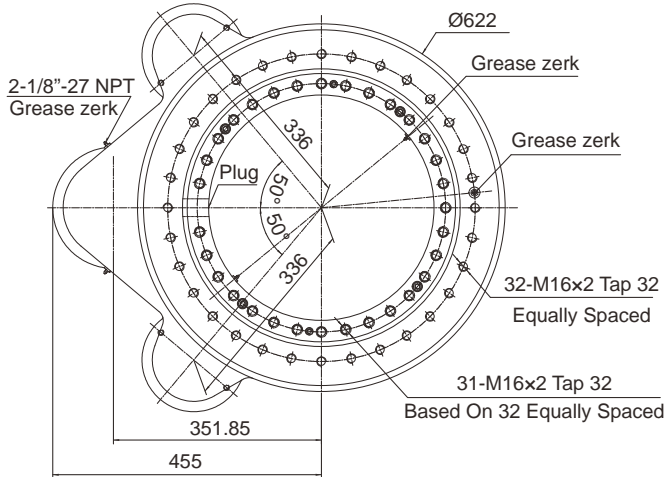

## INPUT

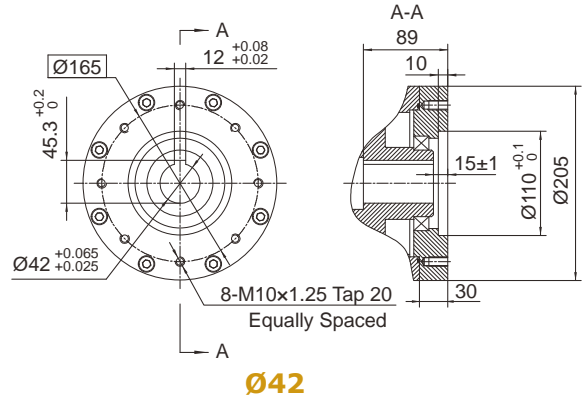

## SPUR GEAR DRIVE PERFORMANCE PARAMETERS

Module	8
Gear Ratio	4.8 : 1
Radial Load (max)	1000 kN
Axial Load (max)	2800 kN
Output Torque (max)	18.5 kN.m
Tilting Moment (max)	250 kN.m
Number of Teeth (wheel)	72
Number of Teeth (pinion)	15

## SIDE

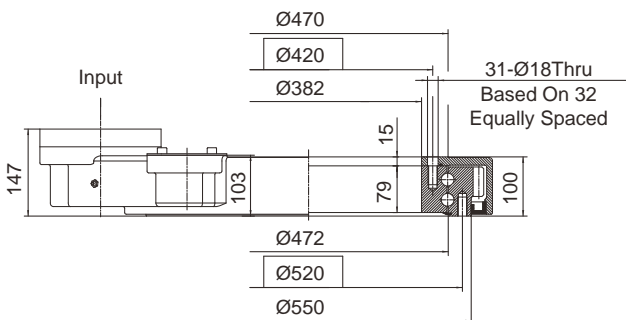

## MOMENT LOAD CHART

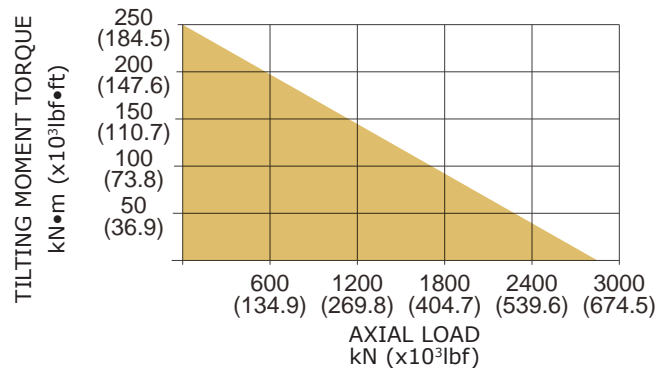

All dimensions in mm unless otherwise specified

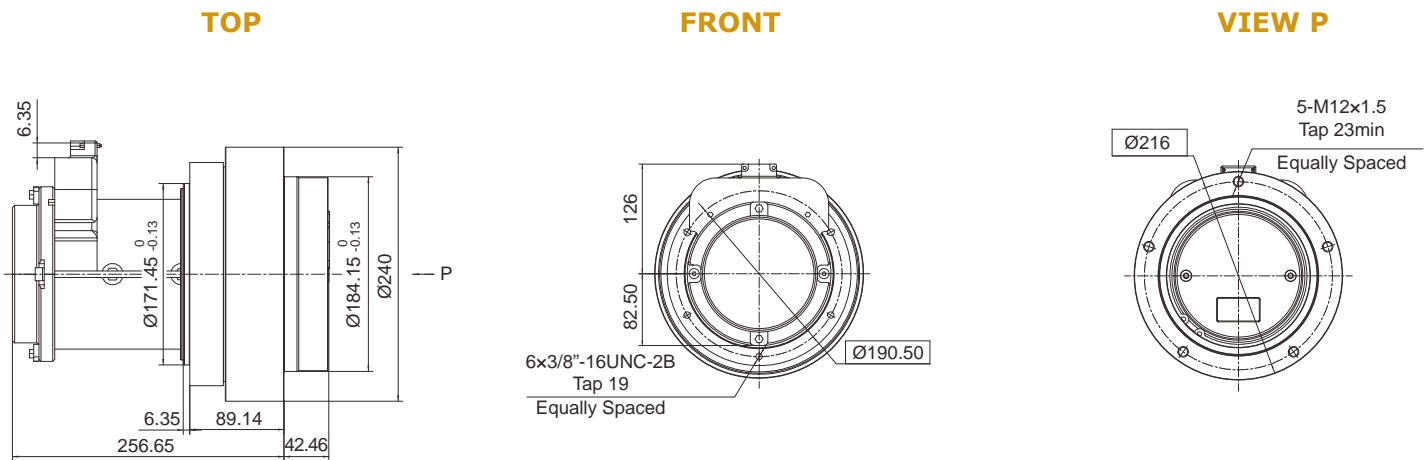

## WHEEL DRIVE PERFORMANCE PARAMETERS

Item	DC Drive Parameters	AC Drive Parameters
Application Type	8-14m Scissor Lift (Electric Drive)	14-16m Scissor Lift (Electric Drive)
Gradeability	25%	25%
Ratio	45.13:1	45.13:1
Output Type	Hub Output	Hub Output
Rated Output Torque (Nm)	395	500
Output Torque (Max) (Nm)	790	1000
Rim Bolts Circle Diameter (mm)	216	216
Rim Bolts Specification	5-M12x1.5	5-M12x1.5
Rim Pilot Diameter (mm)	184.15 <sup>0</sup> <sub>-0.13</sub>	184.15 <sup>0</sup> <sub>-0.13</sub>
Outer Diameter of Reducer Housing (Max)	240	240
Frame Installation Pilot Depth (mm)	6.35	6.35
Frame Installation Pilot Diameter (mm)	171.45 <sup>0</sup> <sub>-0.13</sub>	171.45 <sup>0</sup> <sub>-0.13</sub>
Frame Mounting Bolts Circle Diameter (mm)	190.50	190.50
Frame Mounting Bolts Specification	6-3/8"-16UNC	6-3/8"-16UNC
Distance from Rim Mounting Surface to Motor Rear (mm)	256/218	258
Voltage(V)	24V DC Motor	24V AC Motor
Power(W)	800	870/1000
Rated Braking Torque(Nm)	20	20



## SLEW DRIVE INSTALLATION AND MAINTENANCE MANUAL

**IMPORTANT:** In any applications of Cone Drive Products where breakage, damage, disconnection, any other malfunction of any drive train component, or excessive wear could result in personal injury or property damage, a failsafe device capable of stopping and holding the load in the event of such an occurrence must be incorporated after the drive train.

### THE FOLLOWING INFORMATION IS FOR YOUR PROTECTION. PLEASE READ CAREFULLY.

- The following instructions provide the information needed for correct installation and maintenance of slew drives. Do not attempt to install or operate the slew drive until all of the instructions are read and thoroughly understood. If you have any questions, please contact Cone Drive.
- Exceeding the product ratings, output speed, or duty cycle will void the warranty. Please contact Cone Drive with any questions regarding rating and service factors.
- This product is provided without protective covers. It is the responsibility of the purchaser or user to provide guards for all exposed gearing, shafting, couplings, sprockets, sheaves, belts chains or any other moving parts in accordance with local, state and federal requirements.
- The slew drive has moving mechanical components and is typically connected to electrical or hydraulic components which operate under high voltage or pressure. Operation and repair should only be done by qualified personnel.
- Do not alter the product without approval from Cone Drive.



## 1. Mounting Orientations

It is important to consider the source of potential contamination when mounting the slew drive and provide appropriate protective measures.

When mounting a slew drive vertically, we recommend mounting it in the worm over position. This will provide contamination protection for the gearing and bearings (see Figure 1).

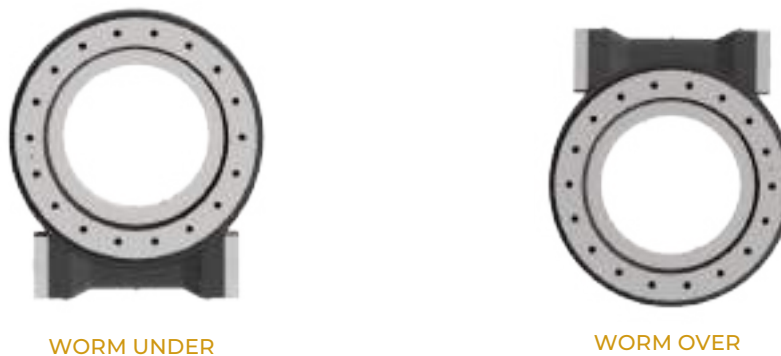

FIGURE 1. VERTICAL MOUNTING ORIENTATIONS

When mounting a slew drive horizontally, we recommend mounting it with the housing up. This will provide contamination protection for the gearing and bearings (see Figure 2).



FIGURE 2. HORIZONTAL MOUNTING ORIENTATIONS

## 2. Transportation, Handling, & Storage

### Transportation

When transporting the slew drive take special care to avoid impacts with the unit. The exposed nature of the slew drive can result in damage. Slew drives come with the backlash preset. Impacts can alter this setting resulting in poor or excessive contact in the gearing.

### Handling

When handling or moving the unit, install appropriately rated eyebolts or hoist rings into the mounting holes in the slew drive.

## Storage

When storing the slew drive for more than 3 months, it is recommended that the grease in the slew drive be purged with new grease prior to start up. (See Section 4- Lubrication).

When storing the slew drive for a period of 5 months or less, store indoors in the as-shipped orientation. Keep the unit away from heat and moisture sources. The slew drive will come with surface corrosion protection that will prevent corrosion for a period of approximately 5 months (if enclosed in the shipping packaging); longer periods of storage require special protective measures.

## 3. Installation of Slew Drive

### Preparation

- Check the slew drive for physical damage.
- Lift the slew drive with eye bolts. Ensure the eye bolts are fully threaded into the bolt hole. Use a minimum thread engagement of 1.5 times the bolt diameter.
- The slew drive shall be mounted in an unloaded condition.

### Cleaning

- Clean the slew drive and bearing mounting surfaces and the mounting structure using a cold solvent. Use a solvent that will not damage the rubber seals of the drive/bearing.
- Take care not to get any solvent into the slew drive bearing or slew drive gear mesh.
- The mounting surface must be clean and smooth. Be sure to remove impurities from the mounting surface (such as rust, corrosion, flash, burrs, paint, welding slag, loose particles, etc.)
- Cleaning the slew drive with steam or pressure washer is not recommended.

### Socket Head Cap Screws and Hex Bolts

• Series W Slew Drives come with socket head cap screws connecting the slew bearing to the housing. The socket head cap screws are recessed into the housing and shall not be removed. Series S Slew Drives come with hex head shipping bolts. Remove and discard these bolts prior to mounting the drive.

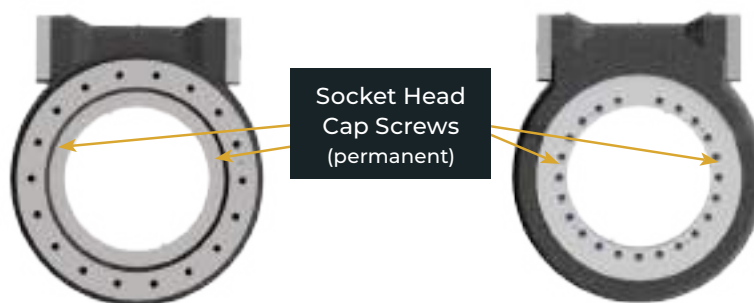

FIGURE 3. SHIPPING BOLTS AND SOCKET HEAD SCREWS

## Permissible Flatness Deviation of the Mounting Surface

To ensure sufficient stiffness to the load transmitted, the slew drive must be mounted on a machined surface/base. This will ensure uniform distribution of the stresses induced to allow minimal deformation in the slew drive bearing.

The allowable degree of flatness deviation of the slew drive mounting surface is shown in Table 1. Measurements are to be taken circumferentially around the mounting surface structure. Peak values should not be measured more than once in 180 degrees and should resemble a smooth sinusoidal curve.

The allowable degree of perpendicularity deviation of the slew drive mounting surface is shown in Table 1. Measurements are to be taken from the inside diameter to the outside diameter of the slew drive/bearing mounting surface.

**TABLE 1. PERMISSIBLE FLATNESS AND PERPENDICULARITY DEVIATIONS**

SIZE	7"	9"	12"	14"	17"	19"	21"	25"
Flatness								
Permissible Flatness Deviation (mm)	0.11	0.16	0.23	0.26	0.32	0.42	0.45	0.49
Permissible Flatness Deviation (°)	0.09	0.09	0.09	0.09	0.09	0.09	0.09	0.09
Perpendicularity								
Perpendicularity Deviation (mm)	0.1	0.12	0.15	0.15	0.15	0.15	0.2	0.2

## Mounting Bolts

As the slew bearing manufacturer, we do not supply, warrant or recommend the mounting fasteners used.

## Tightening Torques

Use of split rings, split washers, or polymeric washers of any kind is not permissible, however it is recommend that the end user use flat washers of appropriate size and strength to minimize the bolt contact pressure.

**TABLE 3. TIGHTENING TORQUES (FOR REFERENCE ONLY)**

METRIC MOUNTING BOLTS		IMPERIAL MOUNTING BOLTS	
MOUNTING BOLT	TIGHTENING TORQUE (Nm)	MOUNTING BOLT	TIGHTENING TORQUE (ft-lb)
	Class 10.9		Grade 8
M8	28	5/16-18UNC	18
M10	55	3/8-16UNC	35
M12	98	1/2-13UNC	80
M16	246	5/8-11UNC	159
M20	481	3/4-10UNC	285
M24	558	7/8-9UNC	455

## Bolt Torque Sequence

- Apply threadlocker to threads (such as Loctite 242 or 271) according to manufacturer's instructions.
- Thread the bolts and washers, if required, into the slew drive, hand tightening each bolt. Tighten one ring at a time. You can start with the inner ring or outer ring but you must follow the tightening procedure until the full tightening torque has been reached before moving to the next ring. The bolts should be tightened in a crosswise pattern as shown in Figure 4. Follow the crosswise pattern tightening each bolt to 30% of the tightening torque. Then repeat crosswise torque pattern tightening each bolt to 50% of tightening torque. Finally repeat the crosswise pattern tightening each bolt to 100% of the tightening torque. Proceed to the other ring and repeat the bolt torque sequence.
- Once a bolt is fully tightened, make a permanent mark on the bolt head and mounting structure. This mark will act as a visual indicator during inspection to confirm the bolt has not loosened.



FIGURE 4. BOLT TORQUE SEQUENCE

## Paint Repair

During installation of the slew drive, any paint that is damaged shall be repaired. Failure to do so could result in corrosion issues and may affect the life of the slew drive.

## 4. Maintenance Checks & Lubrication

### Mounting Bolts and Checks

- To compensate for settling in the system, it is necessary to retighten the bolts to the prescribed torque. This shall be done after approximately 100 hours of operation without external loads applied to the bolt. This inspection shall be repeated annually at a minimum.
- If a loose bolt is discovered, replace the bolt and mating washer with new ones.
- The running condition of the slew drive equipment should be evaluated during use. If excessive noise and vibration are observed, the equipment should be shut down for inspection and troubleshooting.

### Lubrication

- On slew drives, there are three components that require lubrication. These are the slew bearing raceway, the worm gearing, and the worm shaft tapered roller bearings. Slew drives come pre-filled with the grease listed in Table 3. Table 4 has the recommended grease quantities required to fill the units.

**TABLE 3. FACTORY FILLED GREASE**

SPECIFICATION	SLEW BEARING, WORM GEARING, TAPERED ROLLER BEARINGS
Factory grease	Sinopec 7420-1
Applicable Temp. Range in °C	-30 to +120
Color	Black smooth and buttery
Four-ball test	6082 N welding load
Viscosity (40 °C) cSt	1500
Dropping Point °C	180
Penetration, Worked 25°C	315
Recommended Replacement Grease	Mobil, XHP 462-Moly

**TABLE 4. GREASE QUANTITY**

COMPONENTS	QUANTITY OF GREASE-FILL (G)						
	7"	9"	12"	14"	17"	21"	25"
Slew Bearing Raceway	15-20	30-35	45-50	55-60	70-75	120-130	140-150
Worm Gearing	55-65	90-100	100-110	100-110	110-120	130-140	130-140
Worm Tapered Roller Bearing	7±0.5	10±0.5	10±0.5	10±0.5	10±0.5	10±0.5	10±0.5

- Manufacturer provisions for handling the respective lubricants must be observed.
- While rotating the slewing drive, inject grease into the cleaned grease fittings, according to Figure 5
- Inject grease into grease fittings one shot/pump at a time. Each time the grease is injected, the raceway must be filled until grease weeps from the seal surface. When filling the bearing with grease, slowly rotate the bearing to ensure even distribution of the grease.
- Extra care must be taken when greasing the slew bearing to avoid over-pressurizing the bearing casing. Doing so may allow the seal to pop out of the seating surface. If this occurs, the seal must be re-seated prior to operation.

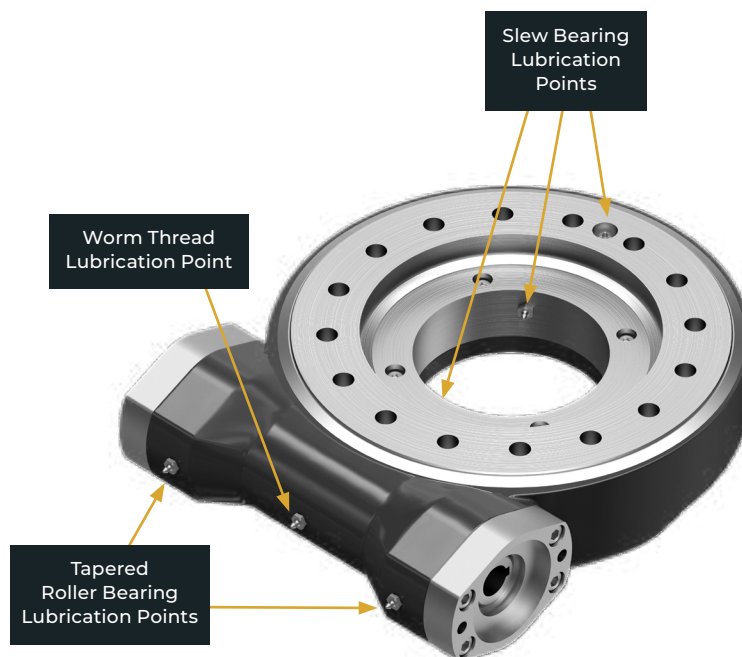

**FIGURE 5. SLEW DRIVE MAINTENANCE POINTS**

- Lubrication intervals for the slew drives are specified in Table 7 and are valid for the following operating conditions:
  - Environmental operating temperatures of -30 °C to +60 °C.
  - Drive rotational output speed < 2 rpm
  - Low to medium drive output torques as shown in Table 5
- Note that it is recommended to completely replace all the grease a minimum of every 3 years by filling each cavity with new grease.

**TABLE 5. LOW TO MEDIUM OUTPUT TORQUES**

SIZE	7"	9"	12"	14"	17"	21"	25"
Output Torque (kN·m)	0.75	3.25	3.75	4	5	7.5	9
Output Torque (ft.lb)	553	2397	2766	2950	3700	5500	6650

**TABLE 6. GREASE-FILLED SLEWING DRIVE RECOMMENDED LUBRICATION INTERVALS**

ENVIRONMENT	PRODUCT TYPE		
	W/S	WE/SE	WEA/SEA
Dry and clean workshop, industrial positioners with shielding (turntables, robots, etc.)	Every 500 hours of operation or once a year	Every 500 hours of operation or once a year	Once a year
Difficult conditions in open grounds (crane, bulldozer, wind turbine, solar, man-lift, etc.)	Every 30 hours of operation or once every 3 months	Every 50 hours of operation or once every 6 months	300 hours of operation or once every 6 months
Aggressive climatic conditions (sea, desert, arctic climate, very dirty surroundings, more than 70 continuous operating hours per week)	Every 25 hours of operation or once every 2.5 months	Every 40 hours of operation or once every 3 months	Every 150 hours of operation or once every 4 months
EXTREME CONDITIONS (tunneling machines, steel mills, oil field)	Every 20 hours of operation, or once every 2 months	Every 30 hours of operation, or once every 3 months	Every 50 hours of operation, or once every 3 months

## Slew Bearing Wear

As a slew bearing wears the amount of tilting clearance will increase. To determine the increase in clearance you must measure the initial clearance of the bearing and record it for future comparisons.

- Determine the maximum tilting moment A-B and mark the measuring point. The measuring point should be as close as possible to the bearing pitch diameter.
- Attach the dial gauge as shown in Figure 6.
- Apply the defined tilting moment, minimum 50% of the max operational load in direction "A". Set the dial gauge to zero.

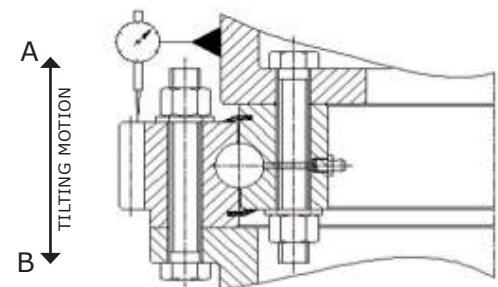

**FIGURE 6. TILTING CLEARANCE MEASUREMENTS**

- Apply the defined tilting moment, minimum 50% of the maximum operational load in “B” direction.
- The measured value displayed corresponds to the tilting clearance and serves as a basis for comparison for later inspections.
- If the recorded increase or delta is larger than the value shown in Table 8, replace the bearing.
- All subsequent measurements are performed at the same measuring point, with the same position of the bearing rings relative to one another and in the same sequence.
- Record all measured values.
- If the bearing has less wear than what is shown in Table 7 but starts to make noise, experiences rough rotation, requires more power to rotate, or has metal shavings in the grease, the bearing should be replaced.

**TABLE 7.** MAXIMUM INCREASE IN BEARING TILT CLEARANCE

BEARING TILT CLEARANCE			
Raceway Diameter (mm)	Rolling Element Diameter (mm)	Allowable Tilt Increase (mm)	Allowable Tilt Increase (in)
< 200	14.00	0.64	0.025
< 300	19.84	0.89	0.035
< 430	22.23	1.02	0.040
< 640	25.40	1.14	0.045
< 830	31.75	1.40	0.055
< 1370	39.69	1.65	0.065
< 4300	60.00	2.29	0.090

## 5. Drive and Control

### Mounting a Hydraulic Motor

- Clean mounting surface faces of motor and slew drive (see Section 3 - Cleaning).
- Check motor hydraulic port mounting position (see Figure 7).
- Tighten motor attachment bolts to appropriate torque level.
- Connect hydraulic supply to motor.
- Rotate the motor and slew drive under no load to confirm smooth rotation.
- Retest after loading is applied.

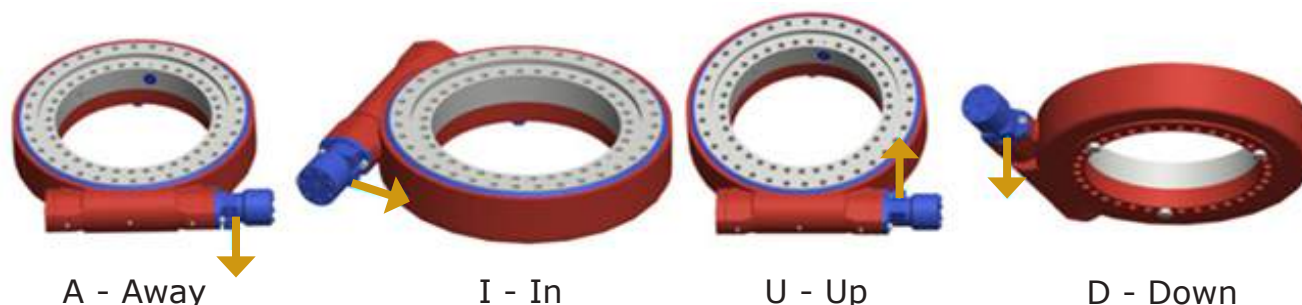
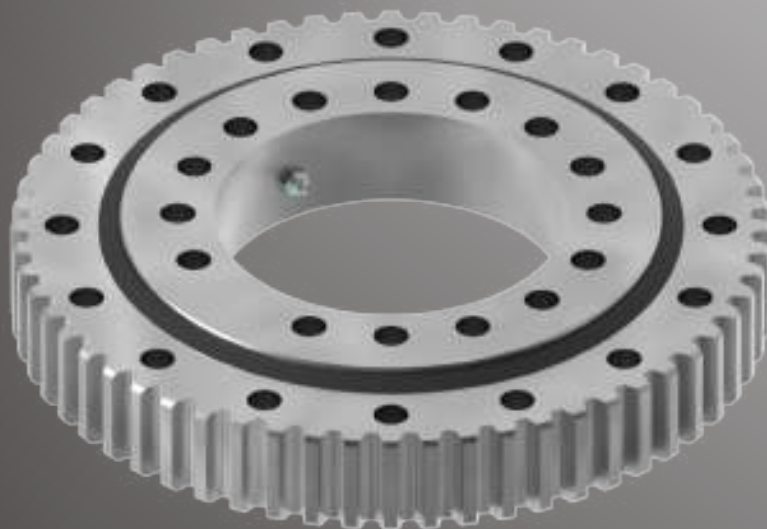

**FIGURE 7.** HYDRAULIC MOTOR OIL PORT POSITION





# SLEWING BEARINGS



### INDUSTRIAL

EXTERNAL TEETH THRU HOLE	EXTERNAL TEETH THREADED HOLE	NO TEETH THRU HOLE	NO TEETH THREADED HOLE
		MTO-122	MTO-122T
		MTO-143	MTO-143T
MTE-145	MTE-145T	MTO-145	MTO-145T
		MTO-170	MTO-170T
MTE-210	MTE-210T	MTO-210	MTO-210T
MTE-265	MTE-265T	MTO-265	MTO-265T
	MTE-324T		MTO-324T
MTE-415	MTE-415T	MTO-415	MTO-415T
MTE-470	MTE-470T	MTO-470	MTO-470T
MTE-540	MTE-540T	MTO-540	MTO-540T
MTE-590	MTE-590T	MTO-590	MTO-590T
MTE-705	MTE-705T	MTO-705	MTO-705T

### FLANGED

NO TEETH	INTERNAL TEETH	EXTERNAL TEETH
RK6-16P1Z	RK6-16N1Z	RK6-16E1Z
RK6-22P1Z	RK6-22N1Z	RK6-22E1Z
RK6-25P1Z	RK6-25N1Z	RK6-25E1Z
RK6-29P1Z	RK6-29N1Z	RK6-29E1Z
RK6-33P1Z	RK6-33N1Z	RK6-33E1Z

**STANDARD BEARING  
NO TEETH**

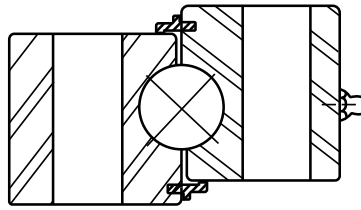

Part Number	Max Moment Rating	Approx. Weight	Outer				Inner			
			Diameter	Bolt Circle Diameter	Hole Qty	Hole Size	Diameter	Bolt Circle Diameter	Hole Qty	Hole Size
			(in)	(in)	#	(in)	(in)	(in)	#	(in)
CD-MTO-050	830	2	4.331	3.818	8	0.26	1.968	2.48	8	0.26
	1,125	0.9	110	97		6.6	50	63		6.6
CD-MTO-050T	830	2	4.331	3.818	8	M6	1.968	2.48	8	M6
	1,125	0.9	110	97		50	63	M6		
CD-MTO-065	1,330	4	5.315	4.724	8	0.354	2.559	3.149	8	0.354
	1,803	1.8	135	120		9	65	80		9
CD-MTO-122	5,020	13	8.898	8.189	12	0.354	4.803	5.512	12	0.354
	6,807	5.9	226	208		9	122	140		9
CD-MTO-122T	5,020	13	8.898	8.189	12	M8 x 1.25	4.803	5.512	12	M8 x 1.25
	6,807	5.9	226	208		122	140	M8 x 1.25		
CD-MTO-143	8,950	15	9.803	8.937	12	0.433	5.63	6.496	12	0.433
	12,136	6.8	249	227		11	143	165		11
CD-MTO-143T	8,950	15	9.803	8.937	12	M10 x 1.5	5.63	6.496	12	M10 x 1.5
	12,136	6.8	249	227		143	165	M10 x 1.5		
CD-MTO-145	26,000	37	11.811	10.63	16	0.571	5.709	6.89	16	0.571
	35,254	16.8	300	270		14.5	145	175		14.5
CD-MTO-145T	26,000	37	11.811	10.63	16	5/8 - 11 UNC-2B	5.709	6.89	16	5/8 - 11 UNC-2B
	35,254	16.8	300	270		145	175	5/8 - 11 UNC-2B		
CD-MTO-145X	30,600	41	12.286	10.63	16	0.591	5.709	6.89	16	0.591
	41,492	18.6	312	270		15	145	175		15
CD-MTO-170	16,520	33	12.205	11.024	12	0.512	6.693	7.874	12	0.512
	22,400	15	310	280		13	170	200		13
CD-MTO-170T	16,520	33	12.205	11.024	12	M12 x 1.75	6.693	7.874	12	M12 x 1.75
	22,400	15	310	280		170	200	M12 x 1.75		
CD-MTO-210	44,500	38	14.37	13.19	16	0.571	8.268	9.449	20	0.571
	60,339	17.2	365	335		14.5	210	240		14.5
CD-MTO-210T	44,500	38	14.37	13.19	16	5/8 - 11 UNC-2B	8.268	9.449	20	5/8 - 11 UNC-2B
	60,339	17.2	365	335		210	240	5/8 - 11 UNC-2B		
CD-MTO-210X	52,100	48	14.686	13.19	16	0.591	8.268	9.449	20	0.591
	70,644	21.8	373	335		15	210	240		15

(Gold shaded cells represent stocked bearings)

## STANDARD BEARING NO TEETH (CONTINUED)

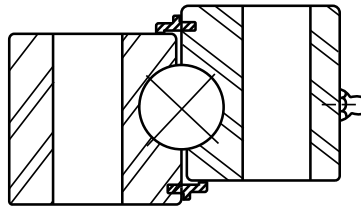

Part Number	Max Moment Rating	Approx. Weight	Outer				Inner			
			Diameter	Bolt Circle Diameter	Hole Qty	Hole Size	Diameter	Bolt Circle Diameter	Hole Qty	Hole Size
			(in)	(in)	#	(in)	(in)	(in)	#	(in)
(ft•lbs)	(lbs)	(mm)	(mm)	#	(mm)	(mm)	(mm)	#	(mm)	
CD-MTO-265	62,000	54	16.535	15.354	18	0.571	10.433	11.614	24	0.571
	84,068	24.5	420	390		14.5	265	295		14.5
CD-MTO-265T	62,000	54	16.535	15.354	18	5/8 - 11 UNC-2B	10.433	11.614	24	5/8 - 11 UNC-2B
	84,068	24.5	420	390		265	295	265		295
CD-MTO-265X	71,900	61	17.086	15.354	18	0.591	10.433	11.614	24	0.591
	97,492	27.7	434	390		15	265	295		15
CD-MTO-324T	102,400	105	20.486	18.875	20	5/8 - 11 UNC-2B	12.75	14.375	20	5/8 - 11 UNC-2B
	138,847	47.6	520	479		324	365	324		365
CD-MTO-324X	102,400	106	20.486	18.875	20	0.688	12.77	14.375	20	0.688
	138,847	48.1	520	479		17.5	324.4	365		17.5
CD-MTO-415	159,000	145	24.65	22.25	16	0.827	16.25	17.75	20	0.827
	215,593	65.8	626	565		21	413	451		21
CD-MTO-415T	159,000	145	24.65	22.25	16	3/4-10 UNC-2B	16.25	17.75	20	3/4-10 UNC-2B
	215,593	65.8	626	565		413	451	413		451
CD-MTO-470	188,000	155	26.9	24.5	18	0.827	18.5	20	24	0.827
	254,915	70.3	683	622		21	470	508		21
CD-MTO-470T	188,000	155	26.9	24.5	18	3/4-10 UNC-2B	18.5	20	24	3/4-10 UNC-2B
	254,915	70.3	683	622		470	508	470		508
CD-MTO-540	232,000	180	29.65	27.25	24	0.827	21.25	22.75	28	0.827
	314,576	81.6	753	692		21	540	578		21
CD-MTO-540T	232,000	180	29.65	27.25	24	3/4-10 UNC-2B	21.25	22.75	28	3/4-10 UNC-2B
	314,576	81.6	753	692		540	578	540		578
CD-MTO-590	338,000	305	33.534	30.625	18	0.945	23.125	24.875	24	0.945
	458,305	138.3	852	778		24	587	632		24
CD-MTO-590T	338,000	305	33.534	30.625	18	7/8-9 UNC-2B	23.125	24.875	24	7/8-9 UNC-2B
	458,305	138.3	852	778		587	632	587		632
CD-MTO-705	443,000	350	38.201	35.25	24	0.945	27.75	29.5	28	0.945
	600,678	158.8	970	895		24	705	749		24
CD-MTO-705T	443,000	350	38.201	35.25	24	7/8-9 UNC-2B	27.75	29.5	28	7/8-9 UNC-2B
	600,678	158.8	970	895		705	749	705		749

(Gold shaded cells represent stocked bearings)

**STANDARD BEARING  
NO TEETH  
(CONTINUED)**

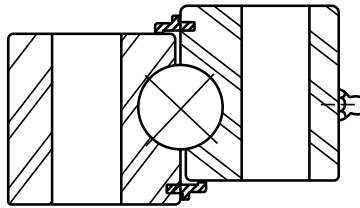

Part Number	Max Moment Rating	Approx. Weight	Outer				Inner			
			Diameter	Bolt Circle Diameter	Hole Qty	Hole Size	Diameter	Bolt Circle Diameter	Hole Qty	Hole Size
			(in)	(in)	#	(in)	(in)	(in)	#	(in)
	(ft-lbs)	(lbs)	(in)	(in)		(in)	(in)		(in)	
	(N•m)	(kg)	(mm)	(mm)	#	(mm)	(mm)	#	(mm)	
CD-MTO-730	587,000	530	41.85	38	20	1.063	28.75	31	24	1.063
	795,932	240.4	1063	965.2		27	730.25	787.4		27
CD-MTO-730T	587,000	529	41.85	38	20	1-8 UNC-2B	28.75	31	24	1-8 UNC-2B
	795,932	240	1063	965.2		730.25	787.4			
CD-MTO-870	873,000	836	47.444	43.875	24	1.181	34.25	36.25	28	1.181
	1,183,729	379.2	1205	1114.425		30	870	920.75		30
CD-MTO-870T	873,000	836	47.444	43.875	24	1-1/8-7 UNC-2B	34.25	36.25	28	1-1/8-7 UNC-2B
	1,183,729	379.2	1205	1114.425		870	920.75			

(Gold shaded cells represent stocked bearings)

## STANDARD BEARING EXTERNAL TEETH

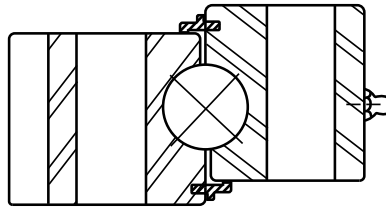

Part Number	Max Moment Rating	Approx. Weight	Outer				Inner			
			Diameter	Bolt Circle Diameter	Hole Qty	Hole Size	Diameter	Bolt Circle Diameter	Hole Qty	Hole Size
			(in)	(in)	#	(in)	(in)	(in)	#	(in)
(ft-lbs)	(lbs)	(in)	(in)	#	(in)	(in)	(in)	#	(in)	
(N•m)	(kg)	(mm)	(mm)	#	(mm)	(mm)	(mm)	#	(mm)	
CD-MTE-145	26,000	38	12.286	10.63	16	0.571	5.709	6.89	15	0.571
	35,254	17.2	312.06	270		14.5	145	175		14.5
CD-MTE-145T	26,000	38	12.286	10.63	16	5/8 - 11 UNC-2B	5.709	6.89	15	5/8 - 11 UNC-2B
	35,254	17.2	312.06	270		145	175	14.5		
CD-MTE-145X	30,600	38	12.286	10.63	16	0.591	5.709	6.89	15	0.591
	41,492	17.2	312.06	270		15	145	175		15
CD-MTE-210	44,500	38	14.686	13.19	16	0.571	8.268	9.449	19	0.571
	60,339	17.2	373.02	335		14.5	210	240		14.5
CD-MTE-210T	44,500	38	14.686	13.19	16	5/8 - 11 UNC-2B	8.268	9.449	19	5/8 - 11 UNC-2B
	60,339	17.2	373.02	335		210	240	14.5		
CD-MTE-210X	52,100	45	14.686	13.19	16	0.591	8.268	9.449	19	0.591
	70,644	20.4	373.02	335		15	210	240		15
CD-MTE-265	62,000	57	17.086	15.354	18	0.571	10.433	11.614	23	0.571
	84,068	25.9	433.98	390		14.5	265	295		14.5
CD-MTE-265T	62,000	57	17.086	15.354	18	5/8 - 11 UNC-2B	10.433	11.614	23	5/8 - 11 UNC-2B
	84,068	25.9	433.98	390		265	295	14.5		
CD-MTE-265X	71,900	58	17.086	15.354	18	0.591	10.433	11.614	23	0.591
	97,492	26.3	434	390		15	265	295		15
CD-MTE-324T	102,400	98	20.486	18.875	20	5/8 - 11 UNC-2B	12.75	14.375	20	5/8 - 11 UNC-2B
	138,847	44.5	520.34	479.4		324	365.1	14.5		
CD-MTE-324X	102,401	100	20.486	18.875	20	0.688	12.77	14.375	20	0.688
	138,849	45.4	520.34	479.425		17.5	324.36	365.125		17.5
CD-MTE-415	159,200	132	24.65	22.25	16	0.827	16.25	17.75	20	0.827
	215,864	59.9	626.11	565.2		21	413	450.9		21
CD-MTE-415T	159,200	132	24.65	22.25	16	3/4 - 10 UNC-2B	16.25	17.75	20	3/4 - 10 UNC-2B
	215,864	59.9	626.11	565.2		413	450.9	14.5		
CD-MTE-470	188,000	155	26.9	24.5	18	0.827	18.5	20	24	0.827
	254,915	70.3	683	622		21	470	508		21
CD-MTE-470T	191,600	147	26.9	24.5	18	3/4 - 10 UNC-2B	18.5	20	24	3/4 - 10 UNC-2B
	259,797	66.7	683.26	622.3		470	508	14.5		

(Gold shaded cells represent stocked bearings)

**STANDARD BEARING  
EXTERNAL TEETH  
(CONTINUED)**

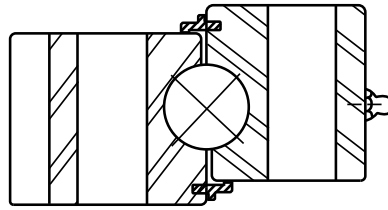

Part Number	Max Moment Rating	Approx. Weight	Outer				Inner			
			Diameter	Bolt Circle Diameter	Hole Qty	Hole Size	Diameter	Bolt Circle Diameter	Hole Qty	Hole Size
	(ft-lbs)	(lbs)	(in)	(in)	#	(in)	(in)	(in)	#	(in)
	(N•m)	(kg)	(mm)	(mm)	#	(mm)	(mm)	(mm)	#	(mm)
CD-MTE-540	232,000	163	29.65	27.25	24	0.827	21.25	22.75	28	0.827
	314,576	73.9	753.11	692.2		21	540	577.9		21
CD-MTE-540T	232,000	163	29.65	27.25	24	3/4 - 10 UNC-2B	21.25	22.75	28	3/4 - 10 UNC-2B
	314,576	73.9	753.11	692.2			540	577.9		
CD-MTE-590	338,700	283	33.534	30.625	18	0.945	23.125	24.875	24	0.945
	459,254	128.4	851.76	777.9		24	587	631.8		24
CD-MTE-590T	338,700	283	33.534	30.625	18	7/8 - 9 UNC 2B	23.125	24.875	24	7/8 - 9 UNC 2B
	459,254	128.4	851.76	777.9			587	631.8		
CD-MTE-705	443,200	325	38.201	35.25	24	0.945	27.75	29.5	28	0.945
	600,949	147.4	970.31	895.4		24	705	749.3		24
CD-MTE-705T	443,200	325	38.201	35.25	24	7/8 - 9 UNC 2B	27.75	29.5	28	7/8 - 9 UNC 2B
	600,949	147.4	970.31	895.4			705	749.3		

(Gold shaded cells represent stocked bearings)



## FLANGED BEARING NO TEETH

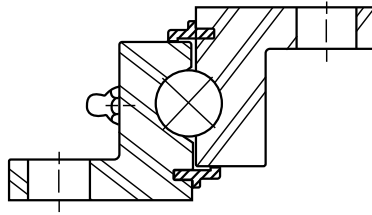

Part Number	Max Moment Rating	Approx. Weight	Outer				Inner			
			Diameter	Bolt Circle Diameter	Hole Qty	Hole Size	Diameter	Bolt Circle Diameter	Hole Qty	Hole Size
			(in)	(in)	#	(in)	(in)	(in)	#	(in)
(ft-lbs)	(lbs)	(in)	(in)	#	(in)	(in)	(in)	#	(in)	
(N•m)	(kg)	(mm)	(mm)		(mm)	(mm)	(mm)		(mm)	
CD-RK6-16P1Z	22,700	58	20.39	19.25	8	0.688	11.97	13.13	12	0.688
	30,780	26.3	518	489		17.5	304	333.5		17.5
CD-RK6-22P1Z	37,700	76	25.51	24.38	12	0.688	17.09	18.13	15	0.688
	51,119	34.5	648	619.3		17.5	434	460.5		17.5
CD-RK6-25P1Z	49,800	89	29.45	28.38	12	0.688	21.03	22.13	18	0.688
	67,525	40.4	748	720.9		17.5	534	562.1		17.5
CD-RK6-29P1Z	54,200	104	33.39	32.25	15	0.688	24.97	26.13	18	0.688
	73,492	47.2	848	819.2		17.5	634	663.7		17.5
CD-RK6-33P1Z	56,500	118	37.32	36.25	18	0.688	28.9	30	18	0.688
	76,610	53.5	948	920.8		17.5	734	762		17.5
CD-RK6-37P1Z	65,200	133	41.26	40.13	18	0.688	32.84	34	20	0.688
	88,407	60.3	1048	1019.3		17.5	834	863.6		17.5
CD-RK6-43P1Z	75,500	152	47.17	46	18	0.688	38.75	39.88	24	0.688
	102,373	68.9	1198	1168.4		17.5	984	1012.952		17.5

(Gold shaded cells represent stocked bearings)

**FLANGED BEARING  
EXTERNAL TEETH**

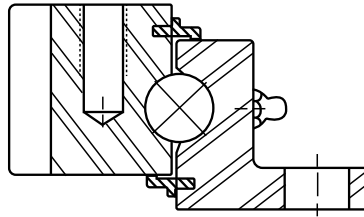

Part Number	Max Moment Rating	Approx. Weight	Outer				Inner			
			Diameter	Bolt Circle Diameter	Hole Qty	Hole Size	Diameter	Bolt Circle Diameter	Hole Qty	Hole Size
			(in)	(in)	#	(in)	(in)	(in)	#	(in)
(N•m)	(kg)	(mm)	(mm)	#	(mm)	(mm)	(mm)	#	(mm)	
CD-RK6-16E1Z	22,700	72	19.9	18	8	1/2 - 13	11.97	13.13	12	0.688
	30,780	32.7	505.46	457.2		UNC-2B	304	333.5		17.5
CD-RK6-22E1Z	37,700	96	25.15	23.25	12	1/2 - 13	17.09	18.13	15	0.688
	51,119	43.5	638.81	590.6		UNC-2B	434	460.5		17.5
CD-RK6-25E1Z	49,800	115	29.15	27.25	15	1/2 - 13	21.03	22.13	18	0.688
	67,525	52.2	740.41	692.2		UNC-2B	534	562.1		17.5
CD-RK6-29E1Z	54,200	128	32.9	31	18	1/2 - 13	24.97	26.13	18	0.688
	73,492	58.1	835.66	787.4		UNC-2B	634	663.7		17.5
CD-RK6-33E1Z	56,500	152	37.2	35	18	1/2 - 13	28.9	30	18	0.688
	76,610	68.9	944.88	889		UNC-2B	734	762		17.5
CD-RK6-37E1Z	65,200	172	41.2	38.88	18	1/2-13	32.84	34	20	0.688
	88,407	78	1046.48	987.6		UNC-2B	834	863.6		17.5
CD-RK6-43E1Z	75,500	190	46.87	44.63	20	1/2-13	38.75	39.88	24	0.688
	102,373	86.2	1190.4	1133.602		UNC-2B	984.25	1012.952		17.5

(Gold shaded cells represent stocked bearings)

## FLANGED BEARING INTERNAL TEETH

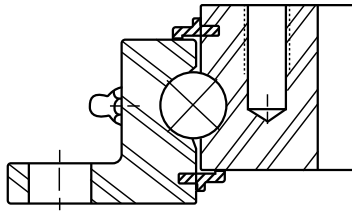

Part Number	Max Moment Rating	Approx. Weight	Outer				Inner			
			Diameter	Bolt Circle Diameter	Hole Qty	Hole Size	Diameter	Bolt Circle Diameter	Hole Qty	Hole Size
			(in)	(in)	#	(in)	(in)	(in)	#	(in)
(ft-lbs)	(lbs)	(in)	(in)	#	(in)	(in)	(in)	#	(in)	
(N•m)	(kg)	(mm)	(mm)		(mm)	(mm)	(mm)		(mm)	
CD-RK6-16N1Z	22,700	65	20.39	19.25	8	0.688	12.85	14.88	12	1/2 - 13 UNC-2B
	30,780	29.5	518	489		17.5	326.39	378		
CD-RK6-22N1Z	37,700	90	25.51	24.38	10	0.688	17.6	19.63	15	1/2 - 13 UNC-2B
	51,119	40.8	648	619.3		17.5	447.04	498.6		
CD-RK6-25N1Z	49,800	106	29.45	28.38	12	0.688	21.6	23.63	18	1/2 - 13 UNC-2B
	67,525	48.1	748	720.9		17.5	548.64	600.2		
CD-RK6-29N1Z	54,200	121	33.39	32.25	15	0.688	25.6	27.63	18	1/2 - 13 UNC-2B
	73,492	54.9	848	819.2		17.5	650.24	701.8		
CD-RK6-33N1Z	56,500	148	37.32	36.25	18	0.688	29.13	31.5	18	1/2 - 13 UNC-2B
	76,610	67.1	948	920.8		17.5	739.98	800.1		
CD-RK6-37N1Z	65,200	172	41.26	40.13	18	1/2-13 UNC-2B	33.13	35.5	20	0.688
	88,407	78	1048	1019.3		841.57	901.7	17.5		
CD-RK6-43N1Z	75,500	188	47.17	46	18	1/2-13 UNC-2B	39.13	41.5	24	0.688
	102,373	85.3	1198	1168.4		993.99	1054.1	17.5		

(Gold shaded cells represent stocked bearings)

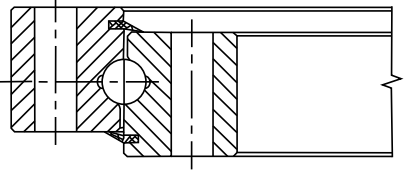
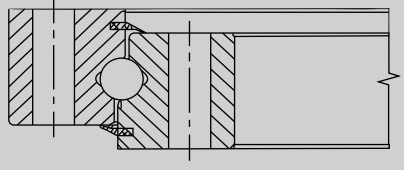
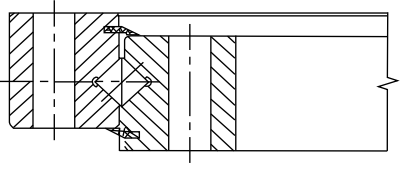
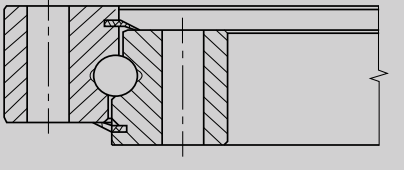
Series		Teeth	Bearing Type		
Series Q	QU	No Teeth	Single Row, Ball Bearing		
	QW	External Teeth			
	QN	Internal Teeth			
Series 01	010	No Teeth	Single Row, Ball Bearing		
	011	012			External Teeth
	013	014			Internal Teeth
Series 11	110	No Teeth	Single Row, Roller Bearing		
	111	112			External Teeth
	113	114			Internal Teeth
Series HS	HSB	No Teeth	Single Row, Ball Bearing		
	HSW	External Teeth			
	HSN	Internal Teeth			

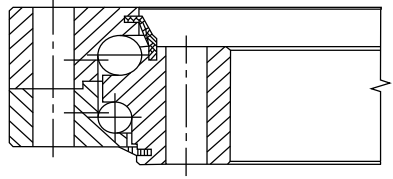
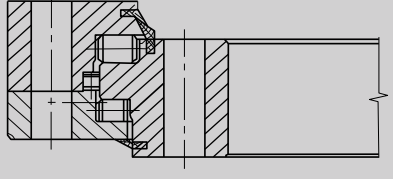
Series		Teeth	Bearing Type		
Series 02	020	No Teeth	Double Row, Ball Bearing		
	021	022			External Teeth
	023	024			Internal Teeth
Series 13	130	No Teeth	Double Row, Roller Bearing		
	131	132			External Teeth
	133	134			Internal Teeth

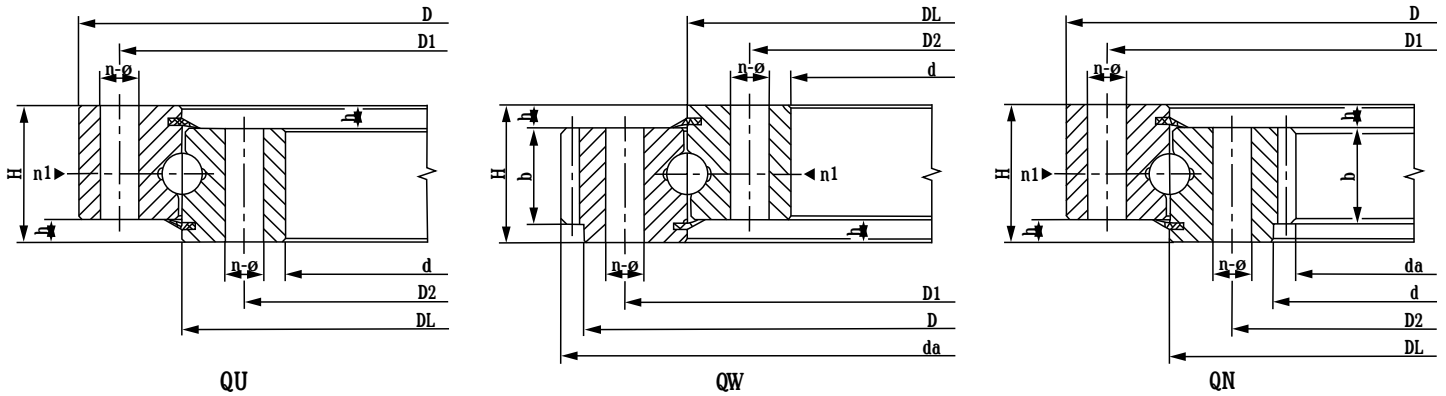

All dimensions in mm unless otherwise specified

Type		Structural Dimension							Mounting Hole Dimension					
QU	QW, QN	QW	QU, QN	QU, QW	QN	H	h	n1	D1	D2	n	Φ	M	T
DL. Steel Ball Spec		D		d										
315.20	315.20	406	408	222	224	60	10	2	370	260	10	17	M16	24
	315.20A													
355.20	355.20	446	448	262	264	60	10	2	410	300	10	17	M16	24
	355.20A													
400.20	400.20	490	493	307	310	60	10	2	455	345	12	17	M16	24
	400.20A													
450.20	450.20	540	543	357	360	60	10	2	505	395	12	17	M16	24
	450.20A													
500.20	500.20	590	593	407	410	60	10	2	555	445	14	17	M16	30
	500.20A													
560.20	560.20	654	656	464	468	70	10	2	618	502	14	17	M16	30
	560.20A													
630.20	630.20	724	726	534	538	70	10	2	688	572	16	17	M16	30
	630.20A													
710.20	710.20	804	806	614	618	70	10	2	768	652	18	17	M16	30
	710.20A													
800.20	800.20	894	896	704	708	70	10	2	858	742	20	17	M16	30
	800.20A													
800.25	800.25	904	908	692	694	78	10	2	864	736	18	22	M20	36
	800.25A													
900.25	900.25	1004	1008	792	794	78	10	2	964	836	20	22	M20	36
	900.25A													
1000.25	1000.25	1104	1108	892	894	78	10	2	1064	936	24	22	M20	36
	1000.25A													
1000.32	1000.32	1120	1124	876	880	90	10	2	1074	926	24	24	M22	40
	1000.32A													
1120.32	1120.32	1240	1244	996	1000	90	10	4	1194	1046	28	24	M22	40
	1120.32A													

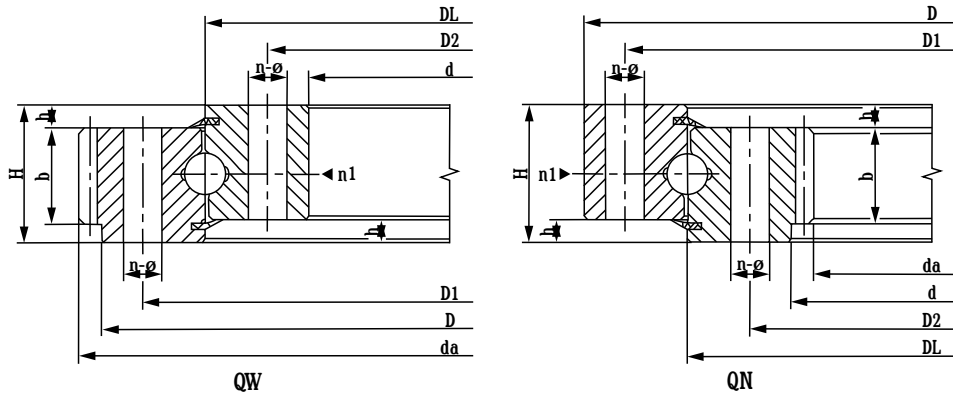

All dimensions in mm unless otherwise specified

Type	Gear Tooth Parameter					
QW, QN	b	m	QW (x = -0.5)		QN (x = +0.5)	
DL. Steel Ball Spec			Z	da	Z	da
315.20	40	3	140	423	70	207
315.20A		4	106	428	51	200
355.20	40	3	153	462	84	249
355.20A		4	116	468	61	240
400.20	40	4	127	512	73	288
400.20A		5	103	520	57	280
450.20	40	4	140	564	85	336
450.20A		5	113	570	67	330
500.20	40	5	122	615	78	385
500.20A		6	103	624	64	378
560.20	50	4	169	680	111	440
560.20A		5	136	685	88	435
630.20	50	4	186	748	129	512
630.20A		5	150	755	102	505
710.20	50	5	166	835	118	585
710.20A		6	139	840	98	582
800.20	50	6	154	930	113	672
800.20A		8	116	936	84	664
800.25	58	6	156	942	110	654
800.25A		8	118	952	82	648
900.25	58	8	130	1048	94	744
900.25A		10	105	1060	75	740
1000.25	58	8	143	1152	107	848
1000.25A		10	115	1160	85	840
1000.32	70	8	144	1160	105	832
1000.32A		10	116	1170	84	830
1120.32	70	10	129	1300	95	940
1120.32A		12	108	1308	79	936



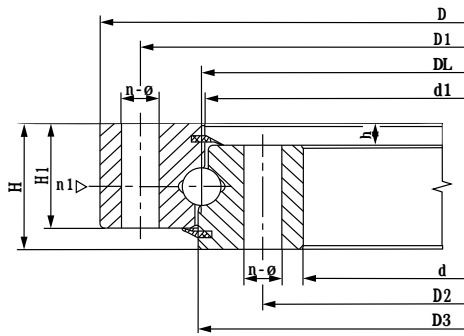

010

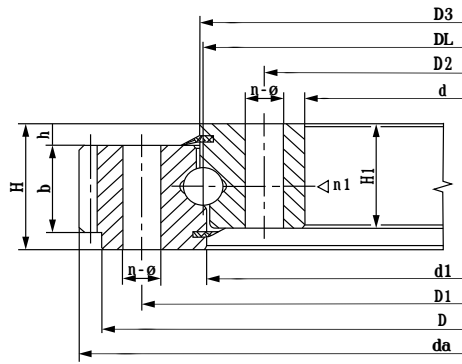

011, 012

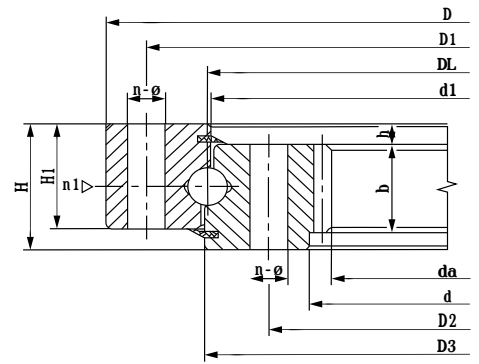

013, 014

All dimensions in mm unless otherwise specified

Type			Configuration & Structural Dimension							Mounting Hole Dimension						
010	011,012	013,014	D	d	H	H1	h	D3	d1	n1	D1	D2	n	Type 0	Type 1, 2, 3	
DL. Steel Ball Spec														Φ	M	T
010.20.200	011.20.200	/	280	120	60	50	10	201	199	2	248	152	12	16	M14	28
010.20.224	011.20.224	/	304	144	60	50	10	225	223	2	272	176	12	16	M14	28
010.20.250	011.20.250	/	330	170	60	50	10	251	249	2	298	202	18	16	M14	28
010.20.280	011.20.280	/	360	200	60	50	10	281	279	2	328	232	18	16	M14	28
010.25.315	011.25.315	013.25.315	408	222	70	60	10	316	314	2	372	258	20	18	M16	32
010.25.355	011.25.355	013.25.355	448	262	70	60	10	356	354	2	412	298	20	18	M16	32
010.25.400	011.25.400	013.25.400	493	307	70	60	10	401	399	2	457	343	24	18	M16	32
010.25.450	011.25.450	013.25.450	543	357	70	60	10	451	449	2	507	393	24	18	M16	32
010.30(25).500	011.30(25).500	013.30(25).500	602	398	80	70	10	501	498	4	566	434	20	18	M16	32
	012.30(25).500	014.30(25).500														
010.30(25).560	011.30(25).560	013.30(25).560	662	458	80	70	10	561	558	4	626	494	20	18	M16	32
	012.30(25).560	014.30(25).560														
010.30(25).630	011.30(25).630	013.30(25).630	732	528	80	70	10	631	628	4	696	564	24	18	M16	32
	012.30(25).630	014.30(25).630														
010.30(25).710	011.30(25).710	013.30(25).710	812	608	80	70	10	711	708	4	776	644	24	18	M16	32
	012.30(25).710	014.30(25).710														
010.40(30).800	011.40(30).800	013.40(30).800	922	678	100	90	10	801	798	6	878	722	30	22	M20	40
	012.40(30).800	014.40(30).800														
010.40(30).900	011.40(30).900	013.40(30).900	1022	778	100	90	10	901	898	6	978	822	30	22	M20	40
	012.40(30).900	014.40(30).900														
010.40(30).1000	011.40(30).1000	013.40(30).1000	1122	878	100	90	10	1001	998	6	1078	922	36	\$22	M20	40
	012.40(30).1000	014.40(30).1000														
010.40(30).1120	011.40(30).1120	013.40(30).1120	1242	998	100	90	10	1121	1118	6	1198	1042	36	\$22	M20	40
	012.40(30).1120	014.40(30).1120														

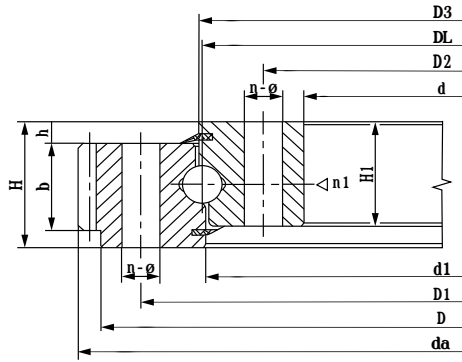

011, 012

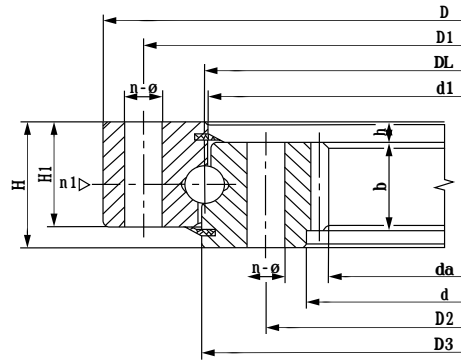

013, 014

All dimensions in mm unless otherwise specified

Type		Gear Tooth Parameter					
011,012	013,014	b	m	011 (012)		013 (014)	
DL. Steel Ball Spec				Z	da	Z	da
011.20.200	/	40	3	98	300	/	/
011.20.224	/	40	3	105	321	/	/
011.20.250	/	40	4	86	352	/	/
011.20.280	/	40	4	94	384	/	/
011.25.315	013.25.315	50	5	85	435	40	190
011.25.355	013.25.355	50	5	93	475	49	235
011.25.400	013.25.400	50	6	86	528	48	276
011.25.450	013.25.450	50	6	94	576	56	324
011.30(25).500	013.30(25).500	60	5	123	629	74	367
012.30(25).500	014.30(25).500		6	102	628.8	62	368.4
011.30(25).560	013.30(25).560	60	5	135	689	86	427
012.30(25).560	014.30(25).560		6	112	688.8	72	428.4
011.30(25).630	013.30(25).630	60	6	126	772.8	83	494.4
012.30(25).630	014.30(25).630		8	94	774.4	62	491.2
011.30(25).710	013.30(25).710	60	6	139	850.8	96	572.4
012.30(25).710	014.30(25).710		8	104	854.4	72	571.2
011.40(30).800	013.40(30).800	80	8	118	966.4	80	635.2
012.40(30).800	014.40(30).800		10	94	968	64	634
011.40(30).900	013.40(30).900	80	8	130	1062.4	93	739.2
012.40(30).900	014.40(30).900		10	104	1068	74	734
011.40(30).1000	013.40(30).1000	80	10	116	1188	83	824
012.40(30).1000	014.40(30).1000		12	96	1185.6	69	820.8
011.40(30).1120	013.40(30).1120	80	10	127	1298	95	944
012.40(30).1120	014.40(30).1120		12	106	1305.6	79	940.8

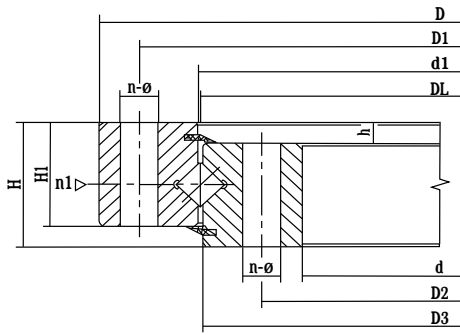

110

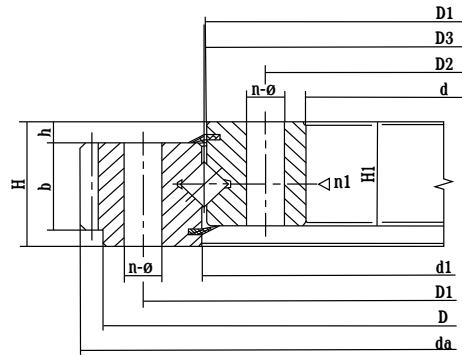

111, 112

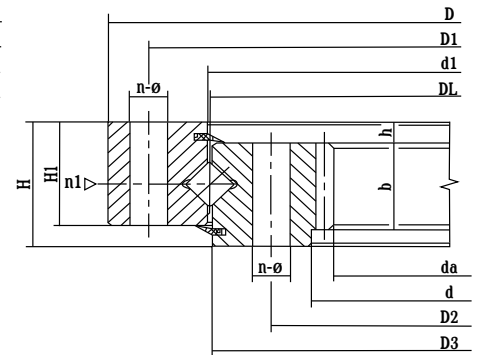

113, 114

All dimensions in mm unless otherwise specified

Type			Configuration & Structural Dimension							Mounting Hole Dimension									
110	111, 112	113, 114	D	d	H	H1	h	D3	d1	n1	D1	D2	n	Type 0			Type 1, 2, 3		
DL. Steel Ball Spec														Φ	M	T	Φ	M	T
110.25.500	111.25.500	113.25.500	602	398	75	65	10	498	502	4	566	434	20	18	M16	32			
	112.25.500	114.25.500																	
110.25.560	111.25.560	113.25.560	662	458	75	65	10	558	562	4	626	494	20	18	M16	32			
	112.25.560	114.25.560																	
110.25.630	111.25.630	113.25.630	732	528	75	65	10	628	632	4	696	564	24	18	M16	32			
	112.25.630	114.25.630																	
110.25.710	111.25.710	113.25.710	812	608	75	65	10	708	712	4	776	644	24	18	M16	32			
	112.25.710	114.25.710																	
110.28.800	111.28.800	113.28.800	922	678	82	72	10	798	802	6	878	722	30	22	M20	40			
	112.28.800	114.28.800																	
110.28.900	111.28.900	113.28.900	1022	778	82	72	10	898	902	6	978	822	30	22	M20	40			
	112.28.900	114.28.900																	
110.28.1000	111.28.1000	113.28.1000	1122	878	82	72	10	998	1002	6	1078	922	36	22	M20	40			
	112.28.1000	114.28.1000																	
110.28.1120	111.28.1120	113.28.1120	1242	998	82	72	10	1118	1122	6	1198	1042	36	22	M20	40			
	112.28.1120	114.28.1120																	
110.32.1250	111.32.1250	113.32.1250	1390	1110	91	81	10	1248	1252	5	1337	1163	40	26	M24	48			
	112.32.1250	114.32.1250																	

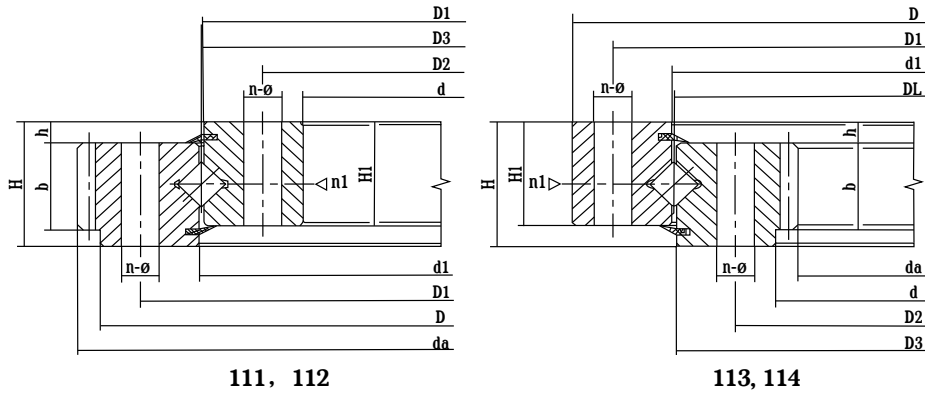

All dimensions in mm unless otherwise specified

Type		Gear Tooth Parameter					
111, 112	113, 114	b	m	111 (112)		113 (114)	
DL. Steel Ball Spec				Z	da	Z	da
111.25.500	113.25.500	60	5	123	629	74	367
112.25.500	114.25.500		6	102	628.8	62	368.4
111.25.560	113.25.560	60	5	135	689	86	427
112.25.560	114.25.560		6	112	688.8	72	428.4
111.25.630	113.25.630	60	6	126	772.8	83	494.4
112.25.630	114.25.630		8	94	774.4	62	491.2
111.25.710	113.25.710	60	6	139	850.8	96	572.4
112.25.710	114.25.710		8	104	854.4	72	571.2
111.28.800	113.28.800	65	8	118	966.4	80	635.2
112.28.800	114.28.800		10	94	968	64	634
111.28.900	113.28.900	65	8	130	1062.4	93	739.2
112.28.900	114.28.900		10	104	1068	74	734
111.28.1000	113.28.1000	65	10	116	1188	83	824
112.28.1000	114.28.1000		12	96	1185.6	69	820.8
111.28.1120	113.28.1120	65	10	127	1298	95	944
112.28.1120	114.28.1120		12	106	1305.6	79	940.8
111.32.1250	113.32.1250	75	12	118	1449.6	88	1048.8
112.32.1250	114.32.1250		14	101	1453.2	75	1041.6

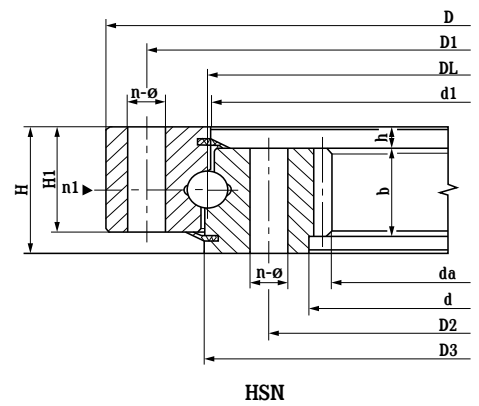
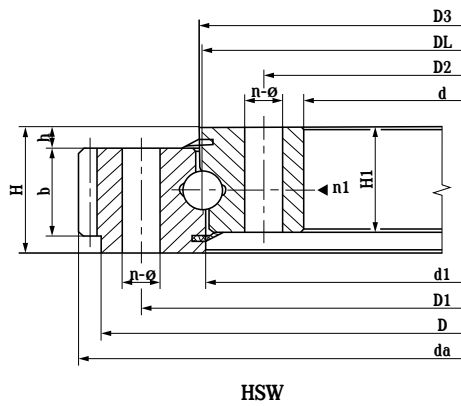
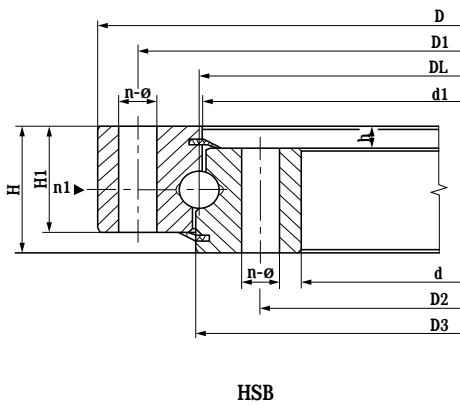

All dimensions in mm unless otherwise specified

Type			Configuration & Structural Dimension								Mounting Hole Dimension					
HSB	HSW	HSN	D	d	H	H1	h	D3	d1	n1	D1	D2	n	Type 0 Φ	Type 1, 2, 3 M T	
DL. Steel Ball Spec																
HSB.25.625	HSW.25.625	HSN.25.625	725	525	80	68	12	626	624	3	685	565	18	18	M16	32
	HSW.25.625A	HSN.25.625A														
HSB.25.720	HSW.25.720	HSN.25.720	820	620	80	68	12	721	719	3	780	660	18	18	M16	32
	HSW.25.720A	HSN.25.720A														
HSB.30.820	HSW.30.820	HSN.30.820	940	705	95	83	12	821	818	4	893	749	24	20	M18	36
	HSW.30.820A	HSN.30.820A														
HSB.30(32).880	HSW.30(32).880	HSN.30(32).880	1000	760	95	83	12	881	878	4	956	800	24	20	M18	36
	HSW.30(32).880A	HSN.30(32).880A														
HSB.30(32).1020	HSW.30(32).1020	HSN.30(32).1020	1170	875	95	80	15	1021	1018	4	1120	930	24	22	M20	40
	HSW.30(32).1020A	HSN.30(32).1020A														

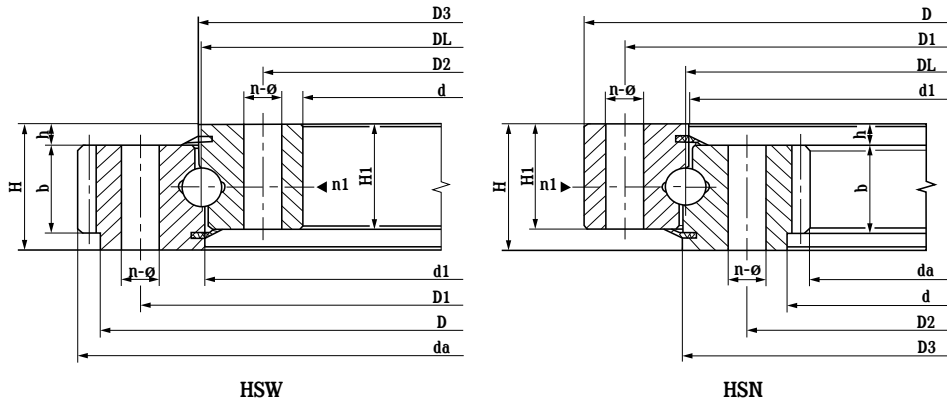

All dimensions in mm unless otherwise specified

Type		Gear Tooth Parameter							
HSW	HSN	b	m	HSW			HSN		
DL. Steel Ball Spec				Z	X	da	Z	X	da
HSW.25.625	HSN.25.625	60	5	146	+1.4	751.9	101	+0.35	498.8
HSW.25.625A	HSN.25.625A		6	122	1.15	755.5	84	+0.35	496.7
HSW.25.720	HSN.25.720	60	6	139	+1.4	860.3	99	+0.35	586.6
HSW.25.720A	HSN.25.720A		8	104	+1.0	861.1	74	+0.35	582.3
HSW.30.820	HSN.30.820	70	6	159	+1.4	980.6	112	+0.35	664.5
HSW.30.820A	HSN.30.820A		10	95	+1.0	986.2	67	+0.35	658
HSW.30(32).880	HSN.30(32).880	70	8	127	+1.15	1047.5	91	+0.35	718.2
HSW.30(32).880A	HSN.30(32).880A		10	101	+1.0	1046.3	72	+0.35	707.9
HSW.30(32).1020	HSN.30(32).1020	70	8	148	+1.4	1219.3	105	+0.35	830.1
HSW.30(32).1020A	HSN.30(32).1020A		10	118	+1.15	1219.2	84	+0.35	827.8

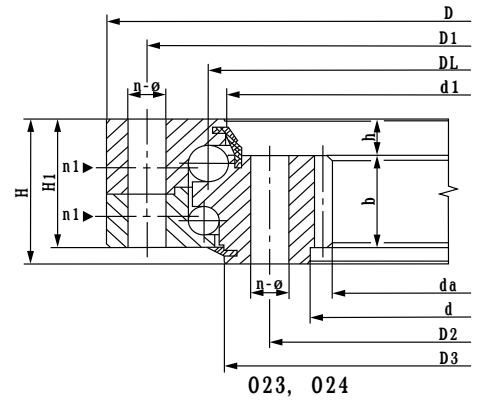
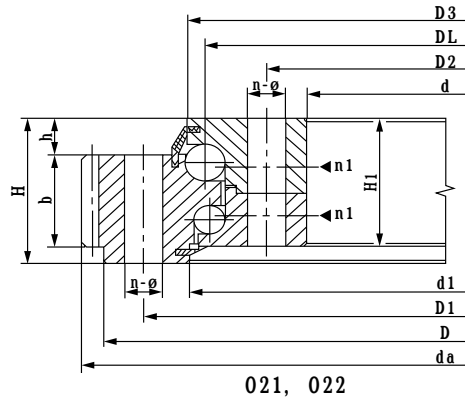
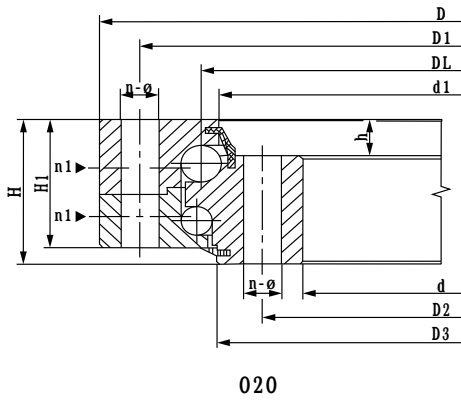

All dimensions in mm unless otherwise specified

Type			Configuration & Structural Dimension										Mounting Hole Dimension					
020	021,022	023,024	D	d	H	H1	h	020 023(024)		021(022)		n1	D1	D2	n	Type 0	Type 1, 2, 3	
DL. Steel Ball Spec								D3	d1	D3	d1					Φ	M	T
020.25.500	021.25.500	023.25.500	616	384	106	96	26	482	477	523	518	4	580	420	20	18	M16	32
	022.25.500	024.25.500																
020.25.560	021.25.560	023.25.560	676	444	106	96	26	543	537	583	578	4	640	480	20	18	M16	32
	022.25.560	024.25.560																
020.25.630	021.25.630	023.25.630	746	514	106	96	26	613	607	653	648	4	710	550	24	18	M16	32
	022.25.630	024.25.630																
020.25.710	021.25.710	023.25.710	826	594	106	96	26	692	687	733	728	4	790	630	24	18	M16	32
	022.25.710	024.25.710																
020.30.800	021.30.800	023.30.800	942	658	124	114	29	777	771	829	823	6	898	702	30	\$22	M20	40
	022.30.800	024.30.800																
020.30.900	021.30.900	023.30.900	1042	758	124	114	29	877	871	929	923	6	998	802	30	22	M20	40
	022.30.900	024.30.900																
020.30.1000	021.30.1000	023.30.1000	1142	858	124	114	29	977	971	1029	1023	6	1098	902	36	\$22	M20	40
	022.30.1000	024.30.1000																



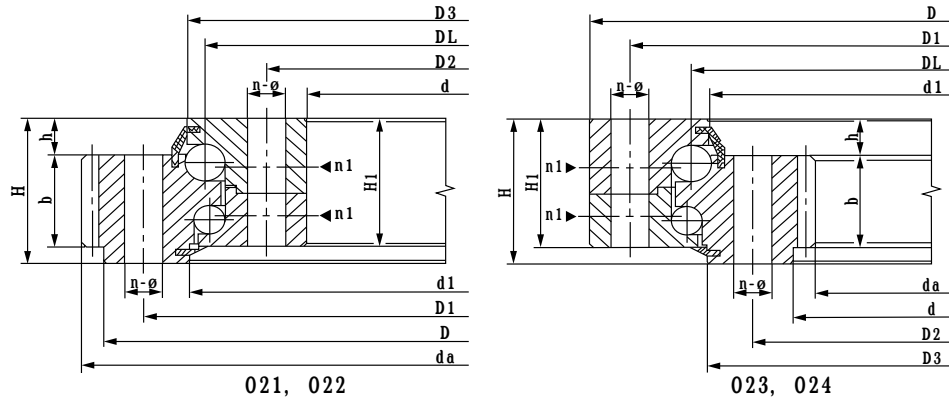

All dimensions in mm unless otherwise specified

Type		Gear Tooth Parameter					
021,022	023,024	b	m	021 (022)		023 (024)	
DL. Steel Ball Spec				Z	da	Z	da
021.25.500	023.25.500	60	5	126	644	72	357
022.25.500	024.25.500		6	105	646.8	59	350.4
021.25.560	023.25.560	60	5	138	704	84	417
022.25.560	024.25.560		6	115	706.8	69	410.4
021.25.630	023.25.630	60	6	129	790.8	81	482.4
022.25.630	024.25.630		8	96	790.4	60	475.2
021.25.710	023.25.710	60	6	141	862.8	94	560.4
022.25.710	024.25.710		8	105	862.4	70	555.2
021.30.800	023.30.800	80	8	120	982.4	78	619.2
022.30.800	024.30.800		10	96	988	62	614
021.30.900	023.30.900	80	8	133	1086.4	90	715.2
022.30.900	024.30.900		10	106	1088	72	714
021.30.1000	023.30.1000	80	10	117	1198	82	814
022.30.1000	024.30.1000		12	97	1197.6	67	796.8

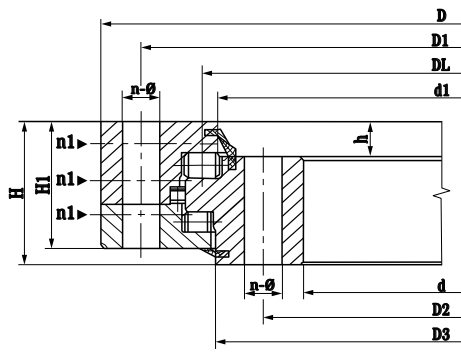

**130**

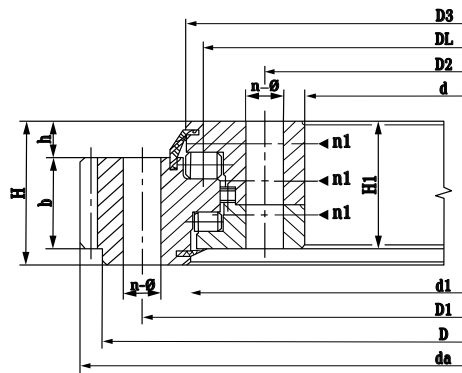

**131, 132**

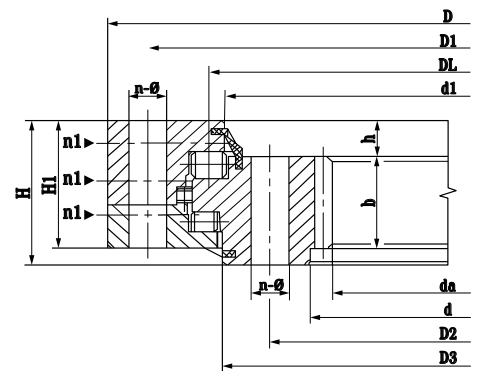

**133, 134**

All dimensions in mm unless otherwise specified

Type			Configuration & Structural Dimension										Mounting Hole Dimension					
130	131, 132	133, 134	D	d	H	H1	h	130 133(134)		131(132)		n1	D1	D2	n	Type 0	Type 1, 2, 3	
DL. Steel Ball Spec								D3	d1	D3	d1					Φ	M	T
130.25.500	131.25.500	133.25.500	634	366	148	138	32	474	463	537	526	4	598	402	24	18	M16	32
	132.25.500	134.25.500																
130.25.560	131.25.560	133.25.560	694	426	148	138	32	534	523	597	586	4	658	462	25	18	M16	32
	132.25.560	134.25.560																
130.25.630	131.25.630	133.25.630	764	496	148	138	32	604	593	667	656	4	728	532	28	18	M16	32
	132.25.630	134.25.630																
130.25.710	131.25.710	133.25.710	844	576	148	138	32	684	673	747	736	4	808	612	28	18	M16	32
	132.25.710	134.25.710																
130.32.800	131.32.800	133.32.800	964	636	182	172	40	770	759	841	830	4	920	680	36	22	M20	40
	132.32.800	134.32.800																
130.32.900	131.32.900	133.32.900	1064	736	182	172	40	870	859	941	930	4	1020	780	36	22	M20	40
	132.32.900	134.32.900																
130.32.1000	131.32.1000	133.32.1000	1164	836	182	172	40	970	959	1041	1030	5	1120	880	40	22	M20	40
	132.32.1000	134.32.1000																
130.32.1120	131.32.1120	133.32.1120	1284	956	182	172	40	1090	1079	1161	1150	5	1240	1000	40	22	M20	40
	132.32.1120	134.32.1120																
130.40.1250	131.40.1250	133.40.1250	1445	1055	220	210	50	1213	1200	1300	1287	5	1393	1107	45	26	M24	48
	132.40.1250	134.40.1250																

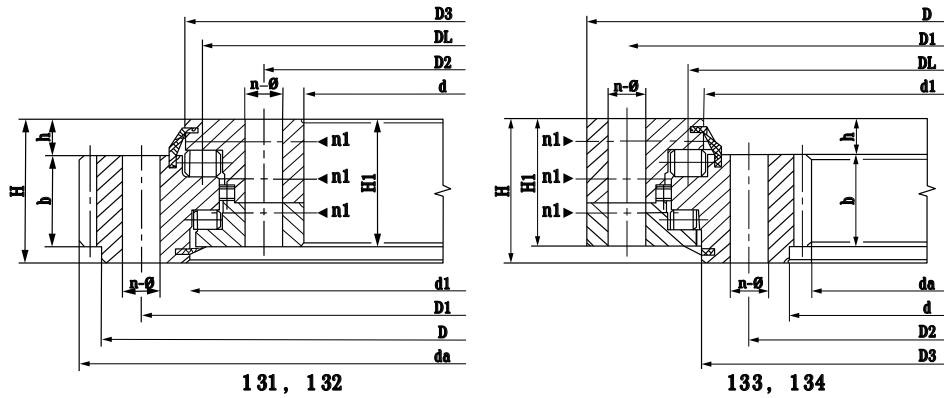

All dimensions in mm unless otherwise specified

Type		Gear Tooth Parameter					
131 (132)	133 (134)	b	m	131 (132)		133 (134)	
DL. Steel Ball Spec				Z	da	Z	da
131.25.500	133.25.500	80	5	130	664	68	337
132.25.500	134.25.500		6	108	664.8	57	338.4
131.25.560	133.25.560	80	5	142	724	80	397
132.25.560	134.25.560		6	118	724.8	67	398.4
131.25.630	133.25.630	80	6	132	808.8	77	458.4
132.25.630	134.25.630		8	98	806.4	58	459.2
131.25.710	133.25.710	80	6	145	886.8	90	536.4
132.25.710	134.25.710		8	108	886.4	68	539.2
131.32.800	133.32.800	120	8	123	1006.4	75	595.2
132.32.800	134.32.800		10	98	1008	60	594
131.32.900	133.32.900	120	8	135	1102.4	87	691.2
132.32.900	134.32.900		10	108	1108	70	694
131.32.1000	133.32.1000	120	10	119	1218	79	784
132.32.1000	134.32.1000		12	99	1221.6	66	784.8
131.32.1120	133.32.1120	120	10	131	1338	91	904
132.32.1120	134.32.1120		12	109	1341.6	76	904.8
131.40.1250	133.40.1250	150	12	123	1509.6	83	988.8
132.40.1250	134.40.1250		14	105	1509.2	71	985.6

## SLEW BEARING INSTALLATION AND MAINTENANCE MANUAL

**IMPORTANT:** In any applications of Cone Drive Products where breakage, damage, disconnection, any other malfunction of any drive train component, or excessive wear could result in personal injury or property damage, a failsafe device capable of stopping and holding the load in the event of such an occurrence must be incorporated after the drive train.

### THE FOLLOWING INFORMATION IS FOR YOUR PROTECTION. PLEASE READ CAREFULLY.

- The following instructions provide the information needed for correct installation and maintenance of slew bearings. Do not attempt to install or operate the slew bearing until all of the instructions are read and thoroughly understood. If you have any questions, please contact Cone Drive.
- Exceeding the product ratings, output speed, or duty cycle will void the warranty. Please contact Cone Drive with any questions regarding rating and service factors.
- This product is provided without protective covers. It is the responsibility of the purchaser or user to provide guards for all exposed gearing, shafting, couplings, sprockets, sheaves, belts chains or any other moving parts in accordance with local, state and federal requirements.
- Operation and repair of the bearings should only be done by qualified personnel.
- Do not alter the product without approval from Cone Drive.

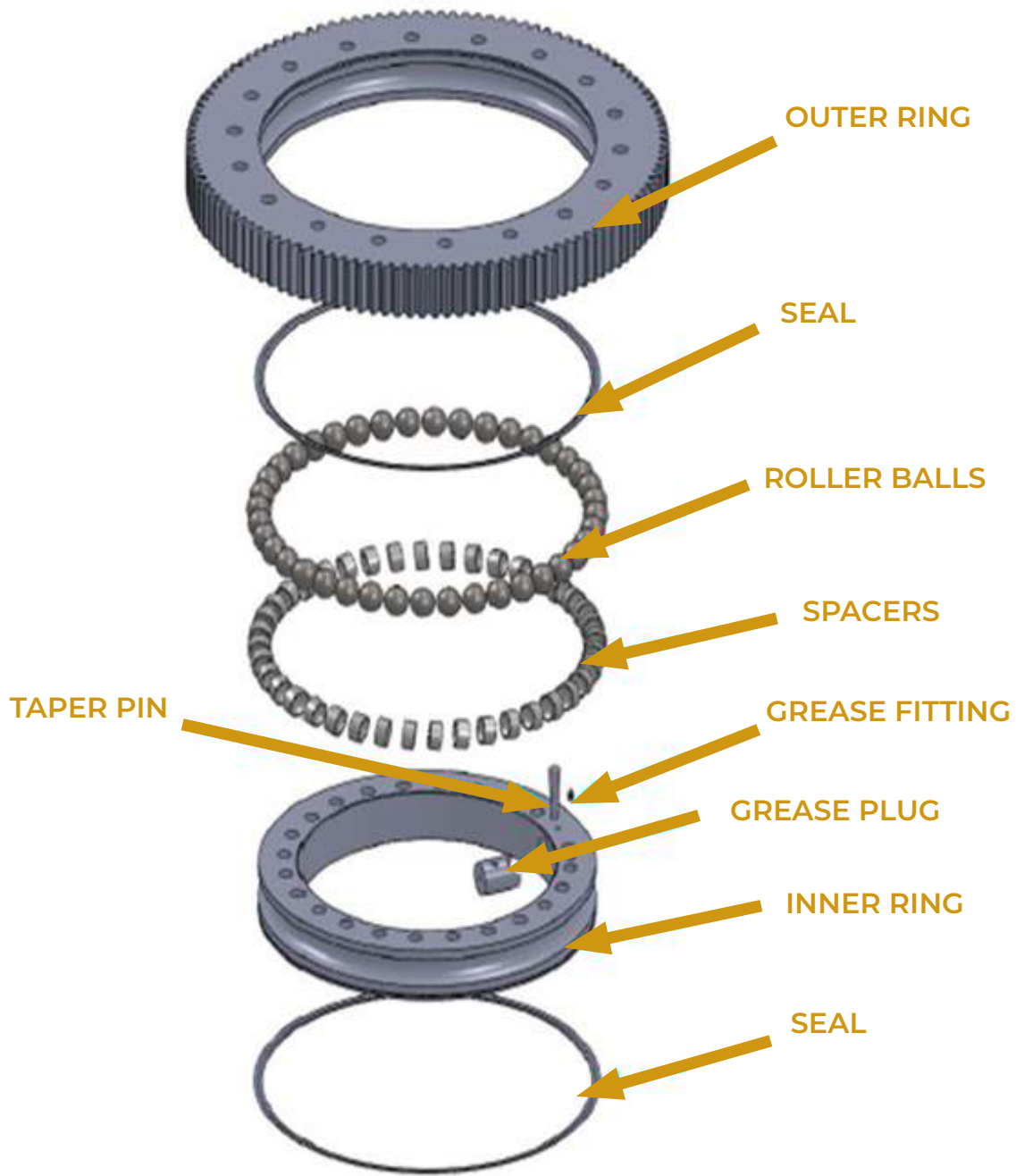

## 1. **Transportation, Handling, & Storage**

### **Transportation**

When transporting the slew bearing take special care to avoid impacts with the unit. The exposed nature of the slew bearing gearing can result in damage.

### **Handling**

When handling or moving the unit, install appropriately rated eyebolts or hoist rings into the mounting holes in the slew bearing.

### **Storage**

When storing the bearing for more than 3 months, it is recommended that the grease in the slew bearing be purged with new grease prior to start up.

When storing the bearing for a period of 5 months or less, store indoors in the as-shipped orientation. Keep the bearing away from heat and moisture sources. Slew bearings will come with surface corrosion protection that will prevent corrosion for a period of approximately 5 months (if enclosed in the shipping packaging); longer periods of storage require special protective measures.

## 2. **Installation of Slewing Bearing**

### **Preparation**

- Check the slew bearing for physical damage.
- Lift the slew bearing with eye bolts. Ensure the eye bolts are fully threaded into the bolt hole. Use a minimum thread engagement of 1.5 times the bolt diameter.
- The slew bearings shall be mounted in an unloaded condition.

### **Cleaning**

- Clean the slew bearing mounting surfaces and the mounting structure using a cold solvent. Use a solvent that will not damage the rubber seals of the bearing.
- Take care not to get any solvent into the slew bearing.
- The mounting surface must be clean and smooth. Be sure to remove impurities from the mounting surface (such as rust, corrosion, flash, burrs, paint, welding slag, loose particles, etc.)
- Cleaning the slew bearings with steam or pressure washer is not recommended.

### **Permissible flatness deviation and maximum allowable deflection of the bearing mounting surface**

To ensure sufficient stiffness to the load transmitted, the slew bearing must be mounted on a machined surface/base. This will ensure uniform distribution of the stresses induced to allow minimal deformation in the slew bearing.

The allowable degree of flatness deviation and the maximum allowable deflection of the bearing mounting surface are shown in Table 1. Measurements are to be taken circumferentially around the mounting surface structure. Peak values should not be measured more than once in 180 degrees and should resemble a smooth sinusoidal curve.

**TABLE 1. PERMISSIBLE FLATNESS DEVIATIONS AND MAX ALLOWABLE DEFLECTION OF THE MOUNTING SURFACE**

Diameter of Raceway (mm)	Flatness Deviation of Mounting Surface (mm)	Maximum Allowable Deflection of Mounting Surface (mm)
< 250	0.04	0.05
250-500	0.05	0.1
500-750	0.09	0.3
750-1000	0.15	0.5
1000-1500	0.2	0.8
1500-2000	0.22	1
2000-2500	0.25	1.2
2500-4000	0.3	1.5

### Mounting surface thickness

The surface thickness of the mounting structure should not be lower than the values shown in Table 2.

**TABLE 2. MOUNTING SURFACE THICKNESS (BASED ON RACEWAY DIAMETER)**

Diameter of Raceway (mm)	500	750	1000	1250	1500	2000	2500	3000
Minimum Thickness (mm)	25	30	35	40	50	60	70	80

### Mounting bolts

As the slew bearing manufacturer, we do not supply, warrant or recommend the mounting fasteners used.

### Tightening Torques

Use of split rings, split washers, or polymeric washers of any kind is not permissible, however it is recommend that the end user use flat washers of appropriate size and strength to minimize the bolt contact pressure.

**TABLE 3. TIGHTENING TORQUES (FOR REFERENCE ONLY)**

METRIC MOUNTING BOLTS		IMPERIAL MOUNTING BOLTS	
MOUNTING BOLT	TIGHTENING TORQUE (Nm)	MOUNTING BOLT	TIGHTENING TORQUE (ft-lb)
	Class 10.9		Grade 8
M8	28	5/16-18UNC	18
M10	55	3/8-16UNC	35
M12	98	1/2-13UNC	80
M16	246	5/8-11UNC	159
M20	481	3/4-10UNC	285
M24	558	7/8-9UNC	455



## Bolt Torque Sequence

- Apply threadlocker to threads (such as Loctite 242 or 271) according to manufacturer's instructions.
- Thread the bolts and washers, if required, into the slew bearing, hand tightening each bolt. Tighten one ring at a time. You can start with the inner ring or outer ring but you must follow the tightening procedure until the full tightening torque has been reached before moving to the next ring. The bolts should be tightened in a crosswise pattern as shown in Figure 1. Follow the crosswise pattern tightening each bolt to 30% of the tightening torque. Then repeat crosswise torque pattern tightening each bolt to 50% of tightening torque. Finally repeat the crosswise pattern tightening each bolt to 100% of the tightening torque. Proceed to the other ring and repeat the bolt torque sequence.
- Once a bolt is fully tightened, make a permanent mark on the bolt head and mounting structure. This mark will act as a visual indicator during inspection to confirm the bolt has not loosened.

FIGURE 1. BOLT TORQUE SEQUENCE

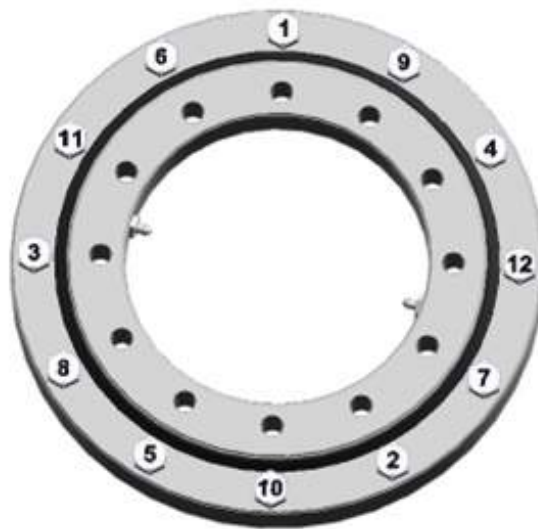

## Paint Repair

During installation of the slew bearing, any paint that is damaged shall be repaired. Failure to do so could result in corrosion issues and may affect the life of the bearing.

## 3. Maintenance, Checks, & Lubrication

### Mounting Bolts and Checks

- To compensate for settling in the system, it is necessary to retighten the bolts to the prescribed torque. This shall be done after approximately 100 hours of operation without external loads applied to the bolt. This inspection shall be repeated annually at a minimum.
- If a loose bolt is discovered, replace the bolt and mating washer with new ones.
- The running condition of the slew bearing equipment should be evaluated during use. If excessive noise and vibration are observed, the equipment should be shut down for inspection and troubleshooting.

## Lubrication

- Slew bearings require raceway to be lubricated and come prefilled with the grease listed in Table 4.
- If servicing the bearing, user must ensure that the grease selected is compatible with the lithium thickener/soap listed in the Sinopec 7408B-1 and 7408B-2. Alternative lubricant recommendation for the slew bearing raceway is listed in Table 5.

**TABLE 4. FACTORY FILLED RACEWAY GREASE**

SPECIFICATION	SLEW BEARING/RACEWAY
Factory Grease	Sinopec 7408B-1 or Sinopec 7408B-2
NLGI Grade	1 or 2
Temperature Range in °C	-20 to +120
Thickener/Soap Type	Lithium Soap
Visual Appearance	Light yellow to brown, smooth and buttery
Viscosity (40 °C) cSt	100
Dropping Point °C	7408B-1: 189 and 7408B-2: 193

**TABLE 5. ALTERNATIVE RACEWAY GREASE (FOR SERVICE)**

BRAND	BEARING/RACEWAY GREASE	OPERATING TEMPERATURE RANGE (°C)
Mobil	XHP 462-Moly	-40 to +200

- Manufacturer provisions for handling the respective lubricants must be observed.
- While rotating the slewing bearing, inject grease into the cleaned grease fittings, according to Figure 2.
- Inject grease into grease fittings one shot/pump at a time. Each time the grease is injected, the raceway must be filled until grease weeps from the seal surface. When filling the bearing with grease, slowly rotate the bearing to ensure even distribution of the grease.
- Extra care must be taken when greasing the bearing to avoid over-pressurizing the bearing casing. Doing so may allow the seal to pop out of the seating surface. If this occurs, the seal must be re-seated prior to operation.
- Lubrication intervals for the slew bearings are specified in Table 6 and are valid for environmental operating temperatures of -30 °C to +60 °C. (Note that it is recommended to completely replace all the grease a minimum of every 3 years by filling the raceway cavity with new grease).

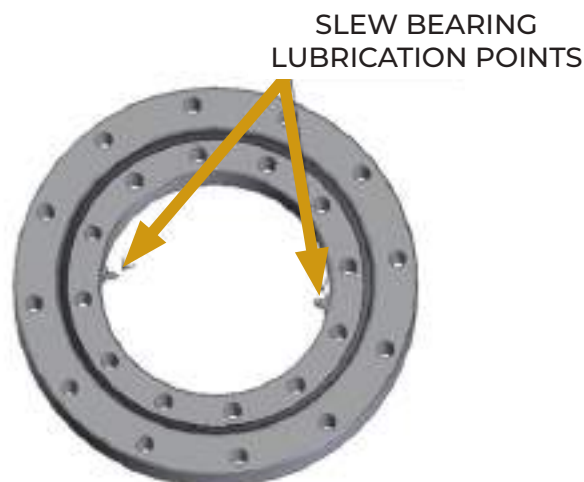

**FIGURE 2. SLEW BEARING MAINTENANCE POINTS**

TABLE 6. RECOMMENDED LUBRICATION INTERVALS

GREASE-FILLED SLEWING BEARING LUBRICATION INTERVALS	
ENVIRONMENT	SLEW BEARING
Dry and clean workshop, industrial positioners with shielding (turntables, robots, etc.)	Every 500 hours of operation or once a year
Difficult conditions in open grounds (crane, bulldozer, wind turbine, solar, man-lift, etc.)	Every 30 hours of operation or once every 3 months
Aggressive climatic conditions (sea, desert, arctic climate, very dirty surroundings, more than 70 continuous operating hours per week)	Every 25 hours of operation or once every 2.5 months
Extreme conditions (tunneling machines, steel mills, oil field)	Every 20 hours of operation, or once every 2 months

- For bearings with either internal or external teeth, grease shall be applied to allow total coverage of the teeth.
- Lubricants recommended for the gear teeth are listed in Table 7.

TABLE 7. RECOMMENDED GREASES FOR BEARINGS WITH INTERNAL OR EXTERNAL GEAR TEETH

BRAND	GEAR GREASE	OPERATING TEMPERATURE RANGE (°C)
Sinopec	7420-1	-30 to +120
Mobil	XHP 462-Moly	-40 to +200
Mobil	Mobiltac 375N	-1 to +121

## Slew Bearing Wear

As a slew bearing wears the amount of tilting clearance will increase. To determine the increase in clearance you must measure the initial clearance of the bearing and record it for future comparisons.

- Determine the maximum tilting moment A-B and mark the measuring point. The measuring point should be as close as possible to the bearing pitch diameter.
- Attach the dial gauge as shown in Figure 3.
- Apply the defined tilting moment, minimum 50% of the maximum operational load in direction "A". Set the dial gauge to zero.
- Apply the defined tilting moment, minimum 50% of the maximum operational load in "B" direction.
- The measured value displayed corresponds to the tilting clearance and serves as a basis for comparison for later inspections.
- If the recorded increase or delta is larger than the value shown in Table 8, replace the bearing.
- All subsequent measurements are performed at the same measuring point, with the same position of the bearing rings relative to one another and in the same sequence.
- Record all measured values.
- If the bearing has less wear than what is shown in Table 8 but starts to make noise, experiences rough rotation, requires more power to rotate, or has metal shavings in the grease, the bearing should be replaced.

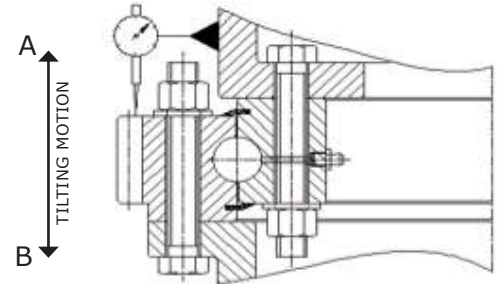

FIGURE 3. TILTING CLEARANCE MEASUREMENTS

TABLE 8. MAXIMUM INCREASE IN BEARING TILT CLEARANCE

BEARING TILT CLEARANCE			
Raceway Diameter (mm)	Rolling Element Diameter (mm)	Allowable Tilt Increase (mm)	Allowable Tilt Increase (in)
< 200	14.00	0.64	0.025
< 300	19.84	0.89	0.035
< 430	22.23	1.02	0.040
< 640	25.40	1.14	0.045
< 830	31.75	1.40	0.055
< 1370	39.69	1.65	0.065
< 4300	60.00	2.29	0.090





# GLOBAL LOCATIONS

NORTH AMERICA | EUROPE | ASIA

